

Instructions for Use

IntelliVue Patient Monitor

MX750/850

Release N with Software Revision N.0x.xx

Patient Monitoring

PHILIPS



Contents

1 Introduction	15
Safety Information	15
Security Information	18
Introducing the Monitor	20
Devices for Acquiring Measurements	21
Operating and Navigating	37
Operating Modes	45
Understanding Screens	46
Viewing Notifications	47
Using the XDS Remote Display	48
Using the Visitors Screen	48
Understanding Profiles	49
Understanding Settings	50
Changing Wave Speeds	52
Freezing Waves	52
Using Labels	53
Entering Measurements Manually	56
Setting Up the Synchronization Output (with MMX or X3 only)	56
Changing Monitor Settings	57
Checking Your Monitor Revision	58
Getting Started	58
Disconnecting from Power	59
Networked Monitoring	59
Using Remote Applications	60
Using the Integrated PC	61
Using Your Monitor with an X2 or X3 in Companion Mode	63
2 Alarms	65
Visual Alarm Indicators	66
Audible Alarm Indicators	67
Acknowledging Alarms	69
Pausing or Switching Off Alarms	70
Alarm Limits	72
Reviewing Alarms	75
Alarm Advisor	76
Latching Alarms	79
Testing Alarms	80
Alarm Behavior at Power On	80
Alarm Recordings	81

3 Patient Alarms and INOPs

83

Patient Alarm Messages

83

Technical Alarm Messages (INOPs)

90

4 Managing Patients and Equipment

119

Patient Concepts

119

Equipment Concepts

119

Bed Management with a Hospital Information System

120

Managing Patients

120

Managing Equipment

134

Care Groups

140

Information Center Compatibility

146

5 ECG, Arrhythmia, ST and QT Monitoring

147

Skin Preparation for Electrode Placement

147

Connecting ECG Cables

147

Selecting the Primary and Secondary ECG Leads

147

Checking Paced Mode

148

Understanding the ECG Display

148

Monitoring Paced Patients

149

Changing the Size of the ECG Wave

150

Changing the Minimum QRS Detection Threshold

151

Changing the Volume of the QRS Tone

151

Changing the ECG Filter Settings

151

Choosing EASI or Standard Lead Placement

152

Selecting Positions of Va and Vb Chest Leads (for 6-electrode placement)

152

About ECG Leads

153

ECG Lead Fallback

154

ECG Lead Placements

154

EASI Lead Placement for a 5-Electrode Cable Set

159

Capture 12-Lead

160

ECG and Arrhythmia Alarm Overview

164

Using ECG Alarms

166

ECG Safety Information

167

About Arrhythmia Monitoring

169

Switching Arrhythmia Analysis On and Off

169

Choosing an ECG Lead for Arrhythmia Monitoring

170

Atrial Fibrillation Alarm

170

Aberrantly-Conducted Beats

170

Intermittent Bundle Branch Block

171

Understanding the Arrhythmia Display

171

Arrhythmia Relearning

173

Arrhythmia Alarms

174

About ST Monitoring

179

Switching ST or STE On and Off	180
Understanding the ST Display	181
Updating ST Baseline Snippets	182
Recording ST Segments	183
About the ST Measurement Points	183
ST Alarms	185
STE Alarms	185
Viewing ST Maps	186
Viewing STE Maps	189
About QT/QTc Interval Monitoring	190
QT Alarms	193
Switching QT Monitoring On and Off	194

6 Monitoring Pulse Rate 195

Entering the Setup Pulse Menu	195
System Pulse Source	195
Switching Pulse On and Off	195
Using Pulse Alarms	196
QRS Tone	197

7 Monitoring Respiration Rate (Resp) 199

Lead Placement for Monitoring Resp	199
Understanding the Resp Display	200
Changing Resp Detection Modes	200
Changing the Size of the Respiration Wave	201
Changing the Speed of the Respiration Wave	201
Using Resp Alarms	201
Changing the Apnea Alarm Delay	202
Resp Safety Information	202

8 Monitoring SpO2 203

Nellcor Patents	203
Masimo Patents	203
SpO2 Sensors	204
Applying the Sensor	204
Connecting SpO2 Cables	205
Measuring SpO2	205
SpO2 Signal Quality Indicator (FAST SpO2 only)	206
Assessing a Suspicious SpO2 Reading	206
Changing the Averaging Time	207
Understanding SpO2 Alarms	207
Pleth Wave	211
Perfusion Numeric	211

Perfusion Change Indicator (Philips FAST SpO2 and Nellcor OxiMax only)	211
Setting SpO2/Pleth as Pulse Source	212
Setting Up Tone Modulation	212
Setting the QRS Volume	212
Calculating SpO2 Difference	212

9 Monitoring with Masimo rainbow SET 213

Masimo Patents	213
Safety Information	213
Alarm Capabilities	218
SpO2 Measurement with Masimo rainbow SET	220

10 Monitoring NBP 229

Introducing the Oscillometric NBP Measurement	229
Preparing to Measure NBP	231
Starting and Stopping Measurements	233
Enabling Automatic Mode and Setting Repetition Time	234
Enabling Sequence Mode and Setting Up The Sequence	235
Choosing the NBP Alarm Source	235
Switching Pulse from NBP On/Off	235
Assisting Venous Puncture	236
Calibrating NBP	236

11 Monitoring Temperature 237

Making a Temp Measurement	237
Calculating Temp Difference	238

12 Measuring Tympanic Temperature 239

Thermometer Display and Controls	240
Making a Temperature Measurement	242
Body Reference Sites and Monitor Labels	243

13 Monitoring Invasive Pressure 245

Setting up the Pressure Measurement	246
Overview of Calibration Procedures	247
Zeroing the Pressure Transducer	248
Calibrating Reusable Transducers	250
Adjusting the Calibration Factor	252
Displaying a Mean Pressure Value Only	252
Changing the Pressure Wave Scale	252
Optimizing the Waveform	252
Using the Wave Cursor	252

Non-Physiological Artifact Suppression	253
Choosing the Pressure Alarm Source	253
Calculating Cerebral Perfusion Pressure	254
Calculating Pulse Pressure Variation	254
Measuring IAP	255
Measuring Pulmonary Artery Wedge Pressure	256
Editing the Wedge	257
Identifying the Pressure Analog Output Connector	258

14 Monitoring Cardiac Output 259

Hemodynamic Parameters	259
Using the C.O. Procedure Window	260
Accessing the Setup C.O. and Setup CCO Menus	262
Entering the HemoCalc Window	262
Measuring C. O. Using the PiCCO Method	262
Measuring C.O. Using the Right Heart Thermodilution Method	266
Documenting C.O. Measurements	269
C.O. Injectate Guidelines	269
C.O./CCO Curve Alert Messages	270
C.O./CCO Prompt Messages	271
C.O./CCO Warning Messages	272
C.O./CCO Safety Information	273

15 Monitoring Carbon Dioxide 275

Measurement Principles	276
Measuring CO ₂ using 867040, M3014A, MMX or X2/X3	277
Measuring Microstream CO ₂ using 867041 or M3015A/B	282
Setting up all CO ₂ Measurements	283
Understanding the IPI Numeric	285

16 Measuring Anesthetic and Respiratory Gases 287

Identifying Gas Analyzer Module Components	288
Water Trap	288
Understanding the Gas Measurement	289
Making Measurements	290
Understanding the Gas Analyzer Display	292
Installing the Water Trap	292
Removing the Water Trap	293
Emptying the Water Trap	294
Water Trap Replacement	295
Changing Settings for the Gas Analyzer	295
Agent Identification	296
MAC Calculation	297

Entering Gas Analyzer Standby Mode	300
Zero Calibration	301
Using the Gas Analyzer During a Cardiopulmonary Bypass	301
Gas Analyzer Safety Information	302

17 Monitoring Intravascular Oxygen Saturation 305

Selecting a Measurement Label	305
Preparing to Monitor with the M1011A SO ₂ Module	306
Checking Suspicious Values	308
Calculating Oxygen Extraction	308

18 Monitoring EEG/aEEG 309

EEG/aEEG Monitoring Setup	310
Using the EEG Impedance/Montage Window	310
About Compressed Spectral Arrays (CSA)	312
Changing EEG Settings	313
About aEEG	314
EEG Reports	315
EEG Safety Information	315
EEG and Electrical Interference	316

19 Monitoring BIS 317

BIS Monitoring Setup	318
BIS Signal Quality Indicator and EMG Indicator	318
BIS Continuous Impedance Check	319
BIS Sensor Check	319
BIS Window	319
Bilateral BIS Measurements	320
Changing the BIS Smoothing Rate	321
Switching BIS and Individual Numerics On and Off	321
Changing the Scale of the EEG Wave	321
Switching BIS Filters On or Off	321
BIS Safety Information	321

20 Monitoring NMT 323

Stimulation Modes	324
Preparing to Measure NMT	324
Taking NMT Measurements	326
Changing the NMT Measurement Settings	328
Alarms	329
Understanding NMT Numerics	329



21 Guardian Early Warning Scoring	331
<hr/>	
Understanding Guardian Early Warning Scoring	331
Performing the Scoring Procedure	332
Triggering Scoring Automatically	334
Viewing EWS Trend Data	334
22 Using a Telemetry Device and a Monitor (PIIC only)	337
<hr/>	
How Can You Combine Devices?	337
Use Models With Telemetry	339
23 Trends	341
<hr/>	
Viewing Trends	341
Setting Up Trends	345
Documenting Trends	348
Trends Databases	349
Screen Trends	349
24 Calculations	353
<hr/>	
Performing Calculations	354
Viewing Calculations	355
Reviewing Calculations	356
Documenting Calculations	356
25 High Resolution Trend Waves	359
<hr/>	
Changing the Hi-Res Trend Waves Displayed	359
Hi-Res Trend Wave Scales	359
Hi-Res Trend Waves and OxyCRG	359
Printing Hi-Res Trend Wave Reports	360
Hi-Res Trend Wave Recordings	360
26 Event Surveillance	361
<hr/>	
Levels of Event Surveillance	361
Event Groups	362
Event Episodes	363
Events Pop-Up Keys	363
Event Triggers	364
The Events Database	368
Viewing Events	368
Annotating Events	371
Documenting Events	371

27 ProtocolWatch	381
SSC Sepsis Protocol	381
28 Recording	387
Paper-Strip Recording	387
Electronic Strip Recording	394
29 Generating Patient Reports	397
Starting Reports	397
Canceling Reports	399
Checking Report Status and Printing Manually	399
Viewing Reports on the Screen	403
Setting Up Printing and Storage for the Print Database	404
Checking Printer Settings	404
Printing a Test Report	405
Switching Printers On or Off for Reports	405
Dashed Lines on Reports	405
Unavailable Printer: Re-routing Reports	405
Printer Status Messages	406
Sample Report Printouts	407
30 Using the Drug Calculator	413
Accessing the Drug Calculator	413
Performing Drug Calculations	414
Charting Infusion Progress	416
Using the Titration Table	416
Documenting Drug Calculations	417
31 IntelliBridge EC10	419
Connecting an External Device	419
Changing Waves and Numerics Displayed	420
Viewing the IntelliBridge Device Data Window	420
Using Screens with External Device Data	420
Alarms/INOPs from External Devices	420
32 Using Timers	423
Viewing Timers	423
Timer Setup Pop-up Keys	423
Setting Up Timers	424
Displaying a Timer On The Main Screen	425
Displaying A Clock On The Main Screen	426



33 Respiratory Loops	427
<hr/>	
Viewing Loops	427
Capturing and Deleting Loops	428
Showing/Hiding Loops	428
Changing Loops Display Size	428
Using the Loops Cursor	428
Changing Loops Type	428
Setting Up Source Device	429
Documenting Loops	429
34 Laboratory Data	431
<hr/>	
Viewing Received Data	431
35 Care and Cleaning	433
<hr/>	
General Points	433
Cleaning the Equipment	434
Disinfecting the Equipment	434
Sterilizing the Equipment	436
Cleaning, Sterilizing and Disinfecting Monitoring Accessories	436
Cleaning the SO2 Optical Module	436
Cleaning and Disinfecting the Tympanic Temperature Accessories	437
Cleaning the Recorder Printhead (M1116B only)	438
36 Maintenance and Troubleshooting	439
<hr/>	
Inspecting the Equipment and Accessories	439
Inspecting the Cables and Cords	440
Maintenance Task and Test Schedule	440
Troubleshooting	441
Returning Equipment for Repair	441
Disposing of the Monitor	442
Disposing of Empty Calibration Gas Cylinders	442
37 Accessories	443
<hr/>	
ECG/Resp Accessories	443
NBP Accessories	446
Invasive Pressure Accessories	449
SpO2 Accessories	449
Temperature Accessories	460
Tympanic Temperature Accessories	460
Cardiac Output (C.O.) Accessories	460
Mainstream CO2 Accessories	461
Sidestream CO2 Accessories	461

Microstream CO2 Accessories	462
G7m Gas Analyzer Accessories	463
EEG Accessories	464
BIS Accessories	464
SO2 Accessories	464
NMT Accessories	465
Recorder Accessories	465

38 Specifications 467

Indications for Use	467
Use Environment	468
Manufacturer's Information	468
Installation Safety Information	469
Symbols	469
Connectors	472
Monitor Mounting Precautions	474
Altitude Setting	474
Monitor Safety Specifications	475
Physical Specifications	475
Environmental Specifications	477
EMC and Radio Regulatory Compliance	480
Monitor Performance Specifications	481
Interface Specifications	486
Display Specifications	491
Measurement Specifications	491
Safety and Performance Tests	519

39 Default Settings Appendix 525

Alarm and Measurement Default Settings	525
Alarm Default Settings	525
ECG, Arrhythmia, ST and QT Default Settings	526
Pulse Default Settings	529
Respiration Default Settings	529
SpO2 Default Settings	530
Masimo rainbow SET Default Settings	531
	534
NBP Default Settings	534
Temperature Default Settings	535
Tympanic Temperature Default Settings	535
Invasive Pressure Default Settings	536
Cardiac Output Default Settings	539
CO2 Default Settings	540
Intravascular Oxygen Saturation Default Settings	541
G7m Gas Analyzer Default Settings	541



EEG/aEEG Default Settings	545
BIS Default Settings	546
NMT Default Settings	546
Index	549



Introduction

These Instructions for Use are for clinical professionals using the IntelliVue MX750/MX850 patient monitors.

This introductory section gives you an overview of the monitor and its functions. It tells you how to perform tasks that are common to all measurements (such as entering data, switching a measurement on and off, setting up and adjusting wave speeds, working with profiles). The alarms section gives an overview of alarms. The remaining sections tell you how to perform individual measurements, and how to care for and maintain the equipment.

Familiarize yourself with all instructions including warnings and cautions, before starting to monitor patients. Read and keep the Instructions for Use that come with any accessories, as these contain important information about care and cleaning that is not repeated here.

This guide describes all features and options. Your monitor may not have all of them; they are not all available in all geographies. Your monitor is highly configurable. What you see on the screen, how the menus appear and so forth, depends on the way it has been tailored for your hospital and may not be exactly as shown here.

This guide may contain descriptions of functionality and features that are not implemented in the equipment currently shipped to Japan and/or of products that are not currently sold in Japan due to limitations and restrictions under the applicable local laws and regulations in Japan. Contact your local sales representative and/or Philips Customer Support for details.

In this guide:

- A **warning** alerts you to a potential serious outcome, adverse event or safety hazard. Failure to observe a warning may result in death or serious injury to the user or patient.
- A **caution** alerts you to where special care is necessary for the safe and effective use of the product. Failure to observe a caution may result in minor or moderate personal injury or damage to the product or other property, and possibly in a remote risk of more serious injury.

Use the monitors and accessories according to their intended use, as stated and described in these Instructions for Use. Disregarding the contents of the Instructions for Use is considered abnormal use.

MX850 Whenever a monitor's identifier appears to the left of a heading or paragraph, it means that the information applies to that monitor only.

For installation, repair, testing and troubleshooting instructions, refer to the Service Guide for your monitor model.

Rx only: U.S. Federal Law restricts this device to sale by or on the order of a physician.

Safety Information

The following warnings apply to the monitors in general. Warnings that apply to specific measurements or procedures can be found in the corresponding chapters.

Electrical Hazards and Interference

WARNING

Grounding: To avoid the risk of electric shock, the monitor must be grounded during operation with mains power. If a three-wire receptacle is not available, consult the hospital electrician. Never use a three-wire to two-wire adapter.

Electrical shock hazard: Do not open the monitor or measurement device. Contact with exposed electrical components may cause electrical shock. Refer servicing to qualified service personnel.

Leakage currents: If multiple instruments are connected to a patient, the sum of the leakage currents may exceed the limits given in:

- IEC/EN 60601-1
- ANSI/AAMI ES60601-1
- CAN/CSA C22.2 No. 60601-1-14

Consult your service personnel.

Radio frequency interference: The monitor generates, uses and radiates radio-frequency energy, and if it is not installed and used in accordance with its accompanying documentation, may cause interference to radio communications.

Use Environment

WARNING

Explosion Hazard: Do not use in the presence of flammable anesthetics or gases, such as a flammable anesthetic mixture with air, oxygen or nitrous oxide or in the presence of other flammable substances in combination with air, oxygen-enriched environments, or nitrous oxide. Use of the devices in such environments may present an explosion hazard.

Positioning Equipment: The monitor should not be used next to or stacked with other equipment. If you must stack the monitor, check that normal operation is possible in the necessary configuration before you start monitoring patients.

Environmental Specifications: The performance specifications for the monitors, measurements and accessories apply only for use within the temperature, humidity and altitude ranges specified in the environmental specifications in the Instructions for Use.

Liquid Ingress: If you spill liquid on the equipment, battery, or accessories, or they are accidentally immersed in liquid, contact your service personnel or Philips service engineer. Do not operate the equipment before it has been tested and approved for further use.

Prohibited Environments: The monitors are not intended for use in an MRI environment or in an oxygen-enriched environment (for example, hyperbaric chambers).

Alarms

WARNING

- Do not rely exclusively on the audible alarm system for patient monitoring. Adjustment of alarm volume to a low level or off during patient monitoring may result in patient danger. Remember that the most reliable method of patient monitoring combines close personal surveillance with correct operation of monitoring equipment.
 - Be aware that the monitors in your care area may each have different alarm settings, to suit different patients. Always check that the alarm settings are appropriate for your patient before you start monitoring.
-

Accessories

WARNING

Philips' approval: Use only Philips-approved accessories. Using other accessories may compromise device functionality and system performance and cause a potential hazard.

Reuse: Never reuse disposable transducers, sensors, accessories and so forth that are intended for single use, or single patient use only. Reuse may compromise device functionality and system performance and cause a potential cross-infection hazard.

Electromagnetic compatibility: Using accessories other than those specified may result in increased electromagnetic emission or decreased electromagnetic immunity of the monitoring equipment.

Damage: Do not use a damaged sensor or one with exposed electrical contacts. Do not use damaged accessories. Do not use accessories where the packaging has been damaged or opened.

Cables and tubing: Always position cables and tubing carefully to avoid entanglement or potential strangulation.

MR Imaging: During MR imaging, remove all transducers, sensors and cables from the patient. Induced currents could cause burns.

Use-by date: Do not use accessories where the use-by date has been exceeded.

Electrosurgery: Do not use antistatic or conductive endotracheal tubes as they may cause burns in case of electrosurgery.

Monitoring

WARNING

Misinterpretation of the measured values or other parameters can endanger the patient. Do not make therapeutic decisions based solely on individual measured values and monitoring parameters.

CAUTION

To avoid incorrect use of the monitor, the Instructions for Use must be made available to the user at all times.

Security Information

Protecting Personal Information

Protecting personal health information is a primary component of a security strategy. Each facility using the monitors must provide the protective means necessary to safeguard personal information consistent with country laws and regulations, and consistent with the facility's policies for managing this information. Protection can only be realized if you implement a comprehensive, multi-layered strategy (including policies, processes, and technologies) to protect information and systems from external and internal threats.

As per its intended use, the patient monitor operates in the patient vicinity and contains personal and sensitive patient data. It also includes controls to allow you to adapt the monitor to the patient's care model.

To ensure the patient's safety and protect their personal health information you need a security concept that includes:

- **Physical security access measures** - access to the monitor **must** be limited to authorized users. It is essential that you consider physical security measures to ensure that unauthorized users cannot gain access.
- **Operational security measures** - for example, ensuring that patients are discharged after monitoring in order to remove their data from the monitor.
- **Procedural security measures** - for example, assigning only staff with a specific role the right to use the monitors.

In addition, any security concept must consider the requirements of local country laws and regulations.

Always consider data security aspects of the network topology and configuration when connecting patient monitors to shared networks. Your medical facility is responsible for the security of the network, where sensitive patient data from the monitor may be transferred.

When a monitor is returned for repair, disposed of, or removed from your medical facility for other reasons, always ensure that all patient data is removed from the monitor by ending monitoring for the last patient (see “Ending Monitoring for a Patient” on page 124).

NOTE

Log files generated by the monitors and measurement modules are used for system troubleshooting and do not contain protected health data.

About HIPAA Rules

If applicable, your facility's security strategy should include the standards set forth in the Health Insurance Portability and Accountability Act of 1996 (HIPAA), introduced by the United States Department of Health and Human Services. You should consider both the security and the privacy rules and the HITECH Act when designing policies and procedures. For more information, please visit:

<http://www.hhs.gov/ocr/privacy/>

About the EU Directives

If applicable, your facility's security strategy should include the practices set forth in the Directive on the protection of individuals with regard to the processing of personal data and on the free movement of such data (Regulation (EU) 2016/679 of the European Parliament and of the Council of 27 April 2016). In addition, your facility should also take into account any additional, more stringent standards put forward by any individual EU countries; that is, Germany, France, and so on.

Philips Product Security Policy Statement

Additional security and privacy information can be found on the Philips product security web site at: <http://www.usa.philips.com/healthcare/about/customer-support/product-security>

Manufacturer Disclosure Statement for Medical Device Security – MDS2

You can view the Manufacturer Disclosure Statements for Medical Device Security (MDS²) for specific devices at:

<http://www.usa.philips.com/healthcare/about/customer-support/product-security>

Cyber Security Requirements and Controls

The IntelliVue Patient Monitor cannot be connected to portable media such as USB drives or CDs. Cyber security threats therefore result mainly from network connectivity and may impact safe and secure operation of your network or any devices attached to this network.

As part of your security concept, you are responsible for establishing controls to protect your network and any networked devices, including the IntelliVue Patient Monitor, against such cyber security threats.

Network Cyber Security Measures

Only connect the IntelliVue Patient Monitor to networks that are explicitly intended for that purpose. The monitor is intended to be used for monitoring of, and to generate alarms for, multiple physiological signals of patients. If you connect the monitor to a network, it is therefore highly recommended that you deploy measures for protecting the network against cyber security threats. This includes the deployment of firewalls to limit remote access and antivirus protection of standard computer systems.

Network Security Requirements for Connectivity to Philips Systems

You must follow the network configuration instructions of the specific Philips system product. For the Philips Information Center, the IntelliVue Network Specification provides detailed network configuration requirements associated with the safe and secure operation of Philips IntelliVue devices within your hospital network for the purpose of patient monitoring. The IntelliVue Network Specification ensures the configuration and operation of a logical isolated network (LAN or VLAN) for IntelliVue devices by the configuration of network infrastructure devices (switches, routers, etc.). The document also defines the interconnection of the isolated network with other hospital networks using firewalls as well as the use of antivirus software for computer platforms based on standard operating systems.

Compliance to the IntelliVue Network Specifications is verified by Philips in cooperation with the customer prior to go-live.

Network Security Requirements for Connectivity to other Systems

To ensure safe and secure operation of networked data collection applications involving IntelliVue Patient Monitors, you must implement network traffic isolation by using dedicated physical or logical networks (isolated VLANs). Network traffic separation can be achieved by configuration of network infrastructure devices (switches, routers and firewalls) as outlined in the IntelliVue Network Specification. Only devices required by the specific system application should share this dedicated network. To prevent malware from affecting network performance or device operation, always ensure that all networked devices with standard operating systems have virus protection installed and kept up to date.

For managing risks in clinical network deployments, Philips recommends that you apply a formal process such as the IEC 80001 series of standards to address safety, effectiveness, and data and system security.

Security Software Updates

All software for the IntelliVue Patient Monitor is completely built and integrated by Philips. There are no separate user-updatable software components from other manufacturers.

Philips authorized software updates for the IntelliVue Patient Monitor, including any potential cyber security updates, are communicated via the Field Change Order Process which is a component of the Philips Quality System. Field Change Orders are published and available on InCenter at:

<http://incenter.medical.philips.com/>.

The procedure on how to install software updates is described within this Field Change Order.

If you have questions about InCenter access, please contact your Philips Patient Monitoring Account Manager or Field Service Engineer.

Introducing the Monitor

The IntelliVue MX family of patient monitors offers a monitoring solution optimized for the high-end surgical, cardiac, medical and neonatal care environments. Combining patient surveillance and data management, it allows multi-measurement monitoring by linking separate modules. The MX750 and MX850 use the touch screen as primary input device.

The monitor stores data in trend, event, and calculation databases. You can see tabular trends (vital signs) and document them on a printer. You can view measurement trend graphs, with up to three measurements combined in each graph, to help you identify changes in the patient's physiological condition. You can view fast-changing measurement trends with beat to beat resolution and see up to four high resolution trend segments. Event surveillance enhances documentation and review of physiologically significant events by automatically detecting and storing up to 50 user-defined clinical events over a 24 hour period.

An IntelliVue X2 or X3 can be connected to your monitor, where it acts as a multi-measurement module, acquiring measurements for the host monitor. When the X2 or X3 is disconnected from the original host monitor, it continues to monitor the patient as a fully independent, battery powered patient monitor, eliminating the need for a separate transport monitor. On connection to a new host monitor, the X2 or X3 resumes its role as multi-measurement module, ensuring fully continuous monitoring.

With the optional Integrated PC, you have computer functionality directly in the monitor. You can use standard applications (e.g. Web browsers), connect to the hospital network or intranet, and run a second independent display with content from the patient monitor.

Major Parts and Keys

MX750/850

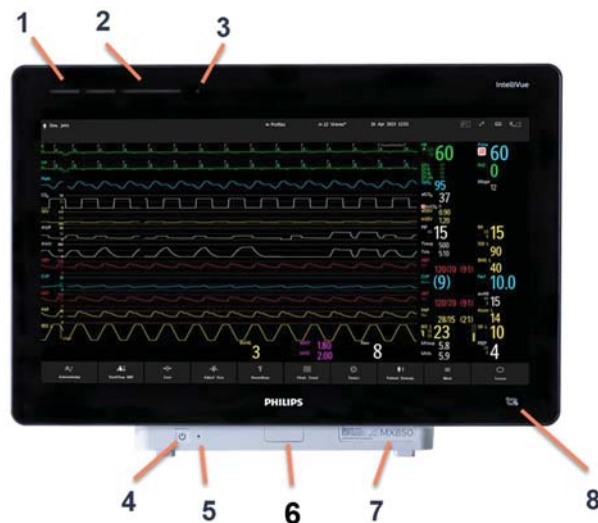

- 1 Color coded alarm lamps
- 2 Alarms Off lamp
- 3 Light sensor used for ambient light adaptation - if the sensor is covered (for example by a sticker), the display cannot adapt to the ambient light conditions
- 4 Monitor on/off switch with integrated LED:
LED off - monitor off

- LED green - monitor on/in Standby mode
- LED red - error condition
- 5 AC power LED
- 6 Mounting quick-release lever (when this is pressed the monitor is not fixed on the mounting)
- 7 Service number and serial number
- 8 NFC Reader

Devices for Acquiring Measurements

The patient monitor acquires patient measurements using the devices described in this section. You can also extend the measurement capabilities of your monitor with such devices. Of these measurement devices, only the X2 and X3 have their own power on switch, and can be powered from an external power supply or a rechargeable battery when not directly connected to the monitor (refer to the IntelliVue X2 and IntelliVue X3 Instructions for Use for details). All the rest take their power exclusively from the monitor, and switch on automatically when you turn on the monitor. A green power-on LED indicates when they are drawing power from the monitor. A permanently illuminated, or flashing, red LED indicates a problem with the unit that requires the attention of qualified service personnel.

All symbols used on the front panels are explained in “Symbols” on page 469.

WARNING

When connecting devices for acquiring measurements, always position cables and tubing carefully to avoid entanglement or potential strangulation.

4-Slot Module Rack (FMX-4)

The 4-Slot Module Rack (FMX-4) lets you use up to four plug-in physiological measurement modules.



The maximum number of specific module types that can be used simultaneously in an FMX-4 is: four pressure modules, four temperature modules, four IntelliBridge modules (any combination).

Connect the FMX to the monitor via the measurement link cable (MSL). Use the Multi-Measurement Module mount on the left-hand side (if you have the appropriate option) to connect an additional Multi-Measurement Module. Use the connector on the back to connect to the monitor.

You can also connect two FMX-4 Module Racks to each other to provide eight module slots for the patient monitor.

Measurement Modules

You can use up to eight measurement modules with up to two FMX-4 (866468) Module Racks. Available modules are:

- Invasive blood pressure (M1006B) - labeled as PRESS for all languages
- Temperature (M1029A) - labeled as TEMP for all languages
- Oxygen saturation of arterial blood (SpO₂) (M1020B)
- Intravascular Oxygen Saturation (M1011A) - labeled as SO₂ for all languages
- Cardiac output (M1012A) - labeled as C.O. for all languages,
Continuous cardiac output with M1012A Option #C10 - labeled as CCO/C.O. for all languages
- EEG (M1027B)
- Bispectral Index - BIS (M1034B)
- NMT (865383)
- IntelliBridge EC10 (865115)
- Recorder (M1116B/C)
- G7m Gas Analyzer (866173)

You can plug in and unplug modules during monitoring. Insert the module until the lever on the module clicks into place. Remove a module by pressing the lever upwards and pulling the module out. A measurement automatically switches on when you plug the module in, and switches off when you unplug it. Reconnecting a module to the same monitor restores its label and measurement settings, such as alarms limits. If you connect it to a different monitor, the module remembers only its label.

The connector socket on the front of each module is the same color as the corresponding connector plug on the transducer or patient cable.

Press the Setup key on the module's front to display the measurement's setup menu on the monitor screen. When the setup menu is open, a light appears above the key. Some modules have a second key. On the pressure module, for example, it initiates a zeroing procedure.









Example Module (Pressure)



- 1 Module name
- 2 Setup key LED
- 3 Setup key to enter setup menu of measurement module or external device data window.
Some modules have a second module-specific key, as in this case the Zero key.
- 4 Connector socket for patient cable/transducer

Module Key Labeling

The key labels on the modules can be either english text or symbols, depending on the module and the language. The following table gives an overview of the text and symbols used for the different modules.

Module	Main Key	Additional Key
	Text label / Symbol	Text label / Symbol
M1006B Pressure	Setup / 	Zero / $\rightarrow 0 \leftarrow$
M1011A ScvO ₂	Setup / 	Cal / ∇
M1012A C.O./CCO	Setup / 	Start / \diamond
M1020B SpO ₂	Setup / No symbol used	-
M1027B EEG	Setup / 	-
M1029A Temperature	Setup / 	-
M1034B BIS	Setup / 	-
865115 IntelliBridge EC10	Setup / No symbol used	-
865383 NMT	Setup / 	Start/Stop / $\diamond \nabla$
866173 G7m Gas Analyzer	Setup / 	Standby / ⏻

MMX Multi-Measurement Module (867036)

The IntelliVue MMX Multi-Measurement Module can simultaneously monitor ECG (using 3-, 5-, 6- or 10-lead sets, including arrhythmia and ST monitoring), respiration, SpO₂, NBP, two invasive pressures, temperature, and CO₂.

You can connect it to the monitor via a cable or mount it on the left side of the Module Rack. The MMX takes its power from the host monitor it is connected to.

WARNING

Ensure that the MMX Multi-Measurement Module is mounted in the horizontal position, to avoid liquid entering the connectors and causing damage to the Multi-Measurement Module.



MMX Connectors and Symbols, Right Side and Front

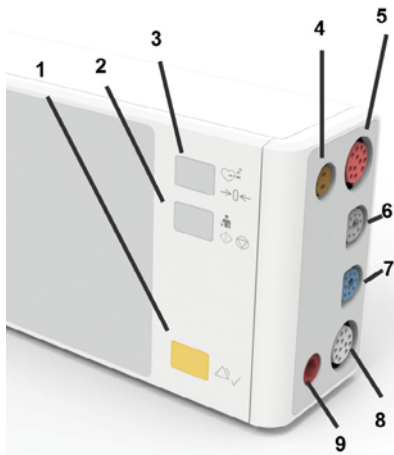

- 1 Acknowledge - acknowledges all active alarms by switching off audible alarm indicators and lamp. (Note that this key may be labeled "Silence" on older devices.)
- 2 NBP Start/Stop key - starts or stops NBP measurements
- 3 NBP STAT key - starts NBP STAT series of measurements
or
Zero key - initiates a zero procedure for the connected pressure transducer (including any pressure transducer in connected Measurement Extensions) when pressed and held for two seconds
- 4 Brown Temperature connector
- 5 Red Dual Pressure connector
- 6 Gray CO₂ connector
- 7 Blue SpO₂ connector
- 8 White ECG/Resp connector
- 9 Red NBP connector

NOTE

The Multi-Measurement Modules are available in several variants. The one shown here is an example. The SpO₂ option shown above is the Philips FAST SpO₂. Also available are:



- SpO₂ measurement and additional derived measurements using Masimo rainbow SET technology
- SpO₂ measurement using Nellcor OxiMax technology

MMX Connectors, Left Side

- 1 Device labeling area (do not cover with additional labels or stickers as the air input/output for the NBP pump is located here)
- 2 MSL Connector - a proprietary interface allowing interconnection of specified Philips devices.

X3 Multi-Measurement Module (867030)

The IntelliVue X3 can simultaneously monitor ECG (using 3-, 5-, 6- or 10-lead sets, including arrhythmia and ST monitoring), respiration, SpO₂, NBP, two invasive pressures, temperature, and CO₂. The multi-touch screen allows easy interaction by sliding and tapping with one or two fingers.

The X3 has the added capability to operate as a stand-alone monitor, and can be powered by a rechargeable battery. This makes it particularly suited to transport situations. When the X3 is disconnected from the original host monitor, it continues to monitor the patient as a stand-alone monitor running on battery power, eliminating the need for a separate transport monitor. When the X3 is connected to a new host monitor, it resumes its role as Multi-Measurement Module, ensuring fully continuous monitoring. For details of using the X3 as a stand-alone monitor, including the use of the external power supply and IntelliVue Dock, refer to the IntelliVue X3 Instructions for Use.

You can connect the X3 to the monitor via a cable or mount it on the left side of the Module Rack.

When connected to a host monitor (Companion Mode is indicated), the X3 takes power from the host, including that required for battery charging. The X3 can also be powered by AC mains when not connected to a host monitor using the IntelliVue Dock (867043). See the IntelliVue X3 Instructions for Use for details.

WARNING

Ensure that the X3 Multi-Measurement Module is mounted in the horizontal position, to avoid liquid entering the connectors and causing damage to the Multi-Measurement Module.

X3 Controls and Indicators

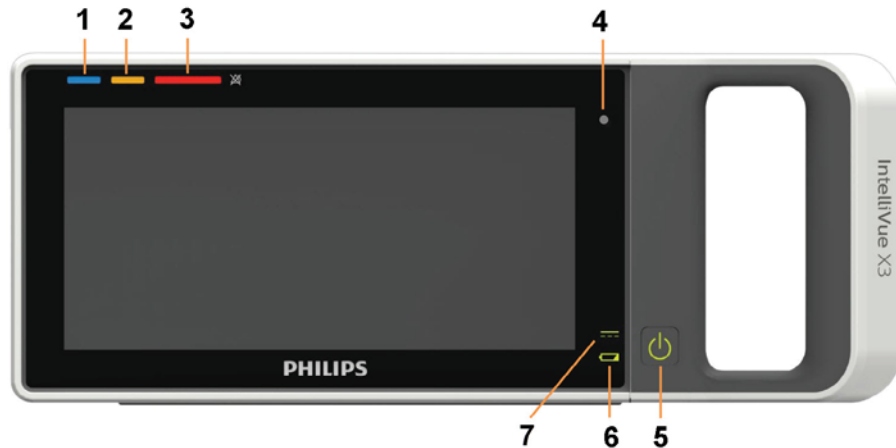

- 1 Active INOP lamp - lights continuously for light blue INOPs, flashes in the appropriate color for red and yellow INOPs.
If no patient alarms are present, red and yellow INOPs will use both lamps (1 and 2).
- 2 Active alarm lamp - red or yellow, depending on the alarm level. The lamp flashes until the active alarm is acknowledged. For short yellow alarms, the lamp lights constantly for approximately six seconds and does not flash.
If no INOPs are present, red and yellow patient alarms will use both lamps (1 and 2).
- 3 Alarms off lamp. When all alarms are off or paused, the lamp is red. When only yellow alarms are off or paused, the lamp is yellow.
- 4 Light sensor used for ambient light adaptation - if the sensor is covered (for example by a sticker), the display cannot adapt to the ambient light conditions.
- 5 Power on/off switch with integrated LED:
 - green - on
 - red - error
- 6 Battery status indicator - green when full, yellow when charging, flashing red when the battery is empty.
- 7 External power indicator - green when the monitor is powered from an external power source.

X3 Patient Connectors, Right Side



- 1 Pressure (option) - one or two pressure lines can be connected.
- 2 Temperature (option, together with pressure)
- 3 CO₂ (option) or alternatively a second SpO₂
- 4 SpO₂ (various options, see below)
- 5 ECG/Respiration
- 6 Noninvasive blood pressure

The connectors may have text labels, as shown above, or symbols, as shown below, depending on local regulatory requirements (e.g. FDA):



The SpO₂ option shown above is the Philips FAST SpO₂. It is the only SpO₂ option that can be combined with the built-in CO₂ or a second Philips FAST SpO₂. Also available are:



- SpO₂ measurement and additional derived measurements using Masimo rainbow SET technology
- SpO₂ measurement using Nellcor OxiMax technology

NOTE

The Multi-Measurement Modules are available in several variants. The ones shown here are examples.

X3 Connectors, Left Side



- 1 Loudspeaker (do not cover with labels or stickers as this will reduce the loudspeaker volume)
- 2 Device labeling area (do not cover with additional labels or stickers as the air input/output for the NBP pump is located here)
- 3 MSL Connector - a proprietary interface allowing interconnection of specified Philips devices.
Connects to:
 - a host monitor
 - IntelliVue Dock for power, battery charging, communication with a network and flexible synchronization output
 - external power supply (M8023A) for power, battery charging, and communication with a network

X1 Multi-Measurement Module (M3001A/M3001AL)

The X1 Multi-Measurement Module (MMS) can simultaneously monitor ECG (using 3-, 5-, 6- or 10-lead sets, including arrhythmia and ST monitoring), respiration, SpO₂, NBP and either invasive pressure or temperature.

You can connect it to the monitor via a cable or mount it on the left side of the Module Rack. The MMS takes its power from the host monitor it is connected to.



X1 Connectors and Symbols

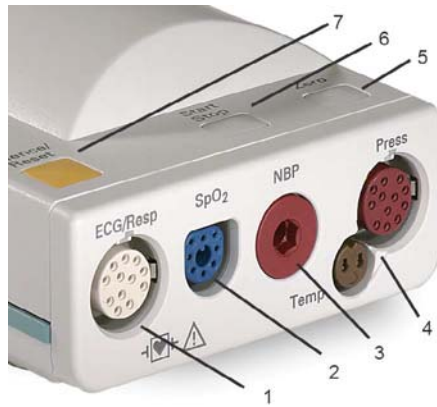

- 1 White ECG/Resp connector
- 2 Blue SpO₂ connector
- 3 Red NBP connector
- 4 Combined pressure (red) and temperature (brown) connector - connect either invasive pressure transducer or temperature probe. You might have a version of the MMS that does not have this connector.
- 5 NBP STAT key - starts NBP STAT series of measurements
or
Zero key - initiates a zero procedure for the connected pressure transducer when pressed and held for two seconds
- 6 NBP Start/Stop key - starts or stops NBP measurements
- 7 Acknowledge: acknowledges all active alarms by switching off audible alarm indicators and lamps (Note that this key may be labeled "Silence" on older devices.)

NOTE

The Multi-Measurement Modules are available in several variants. The one shown here is an example. The SpO₂ option shown above is the Philips FAST SpO₂. Also available are:

- SpO₂ measurement and additional derived measurements using Masimo rainbow SET technology
- SpO₂ measurement and additional derived measurements using Masimo SET technology
- SpO₂ measurement using Nellcor OxiMax technology

X2 Multi-Measurement Module (M3002A)

The X2 Multi-Measurement Module can simultaneously monitor ECG (using 3-, 5-, 6- or 10-lead sets, including arrhythmia and ST monitoring), respiration, SpO₂, NBP and either invasive pressure and temperature, or CO₂. It has a color touchscreen display.

The X2 has the added capability to operate as a stand-alone monitor, and can be powered by a rechargeable battery. This makes it particularly suited to transport situations. When the X2 is disconnected from the original host monitor, it continues to monitor the patient as a stand-alone monitor running on battery power, eliminating the need for a separate transport monitor. When the X2 is connected to a new host monitor, it resumes its role as Multi-Measurement Module, ensuring fully continuous monitoring. For details of using the X2 as a stand-alone monitor, refer to the IntelliVue X2 Instructions for Use.

When connected to a host monitor (**Companion Mode** is indicated), the X2 takes power from the host, including that required for battery charging. The X2 can also be powered by AC mains when not connected to a host monitor using the optionally available external power supply (M8023A). See the IntelliVue X2 Instructions for Use for details.

X2 Overview

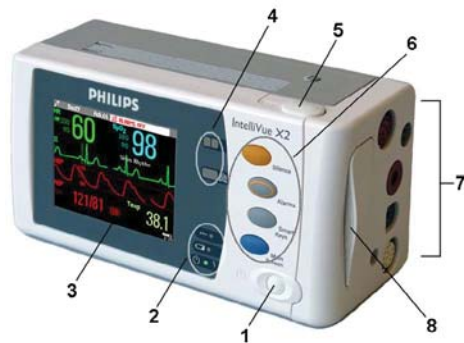

- 1 On/off switch
- 2 Power and battery indicators (see “X2 Controls and Indicators” on page 31)
- 3 3.5-inch TFT LCD touchscreen QVGA display
- 4 Alarm lamps (see “X2 Controls and Indicators” on page 31)
- 5 Battery eject button
- 6 Hard keys (see “X2 Controls and Indicators” on page 31)
- 7 Measurement connectors (see “X2 Patient Connectors, Right Side” on page 31)
- 8 Battery compartment

X2 Controls and Indicators

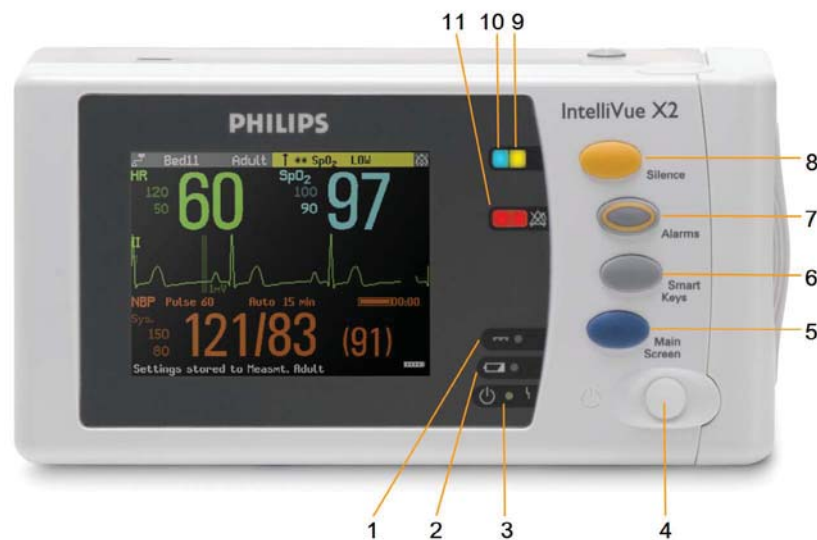

- 1 External power LED. Green when monitor is powered from an external power source.
- 2 Battery status LED. Yellow when charging. Flashing red when battery is empty.
- 3 On/off LED. Green when monitor is on. Red indicates an error.
- 4 On/off switch. Disabled when X2 is connected to a host monitor
- 5 **Main Screen** key: closes all open menus/windows and returns to the main screen.
- 6 **SmartKeys** key: brings up SmartKeys on the screen.
- 7 **Alarms** key: turns alarms On/Off, or pauses them.
- 8 **Acknowledge** key (may be labeled **Silence** on older devices): acknowledges all active alarms by switching off audible alarm indicators and lamps
- 9 Active alarm lamp. Red or yellow, depending on alarm level. Blinks until active alarm is acknowledged.
- 10 Active INOP alarm lamp in light blue. Blinks until active INOP is acknowledged.
- 11 Alarms off indicator. When alarms are suspended, the lamp is red (or yellow when yellow alarms are suspended), and the alarms off symbol is shown.

X2 Patient Connectors, Right Side

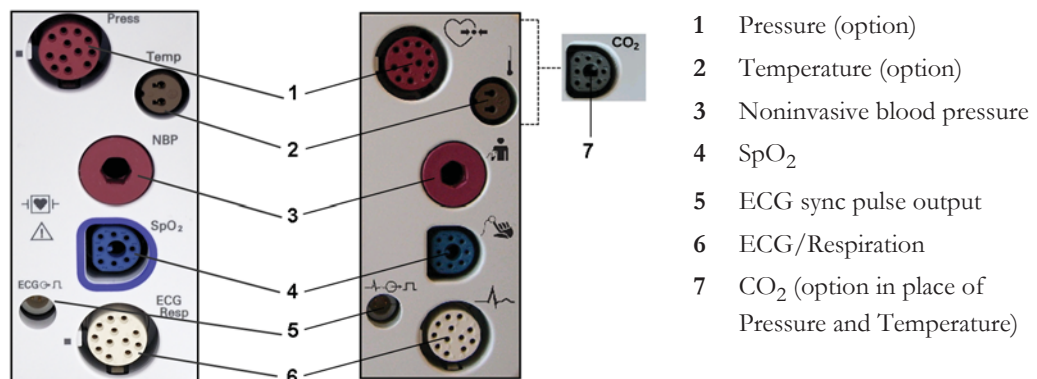

NOTE

The Multi-Measurement Modules are available in several variants. The ones shown here are examples. The SpO₂ options shown above are the Philips FAST SpO₂ and the SpO₂ measurement using Nellcor OxiMax technology. Also available are:

- SpO₂ measurement and additional derived measurements using Masimo rainbow SET technology
- SpO₂ measurement and additional derived measurements using Masimo SET technology

X2 Left Side



- 1 Loudspeaker
- 2 MSL Connector. Connects to the external power supply or a host monitor via the MSL cable for AC mains operation, battery charging, and communication with a network.

Using Multi-Measurement Modules in a Mixed Software Environment

When a Multi-Measurement Module is used with monitors having different software revisions, be aware that functionality set up in a monitor with a newer revision will disappear when the Multi-Measurement Module is connected to a monitor with an older revision without that functionality. For example, if an X2 is used with a revision H monitor and has been set up to alarm on Afib, this alarm will no longer exist when the X2 is connected to a revision G monitor. If you work in a mixed software environment, inform yourself about the differences between revisions by referring to the What's New chapter.

Measurement Extensions

The Measurement Extensions connect to the X1, X2 or X3 or the MMX and use the Multi-Measurement Module's settings and power. Trend data and measurement settings from the measurements in the extensions are stored in the Multi-Measurement Module.

There are two categories of Measurement Extensions:

Measurement Extensions	Differences	Referred to as:
867039, 867040, 867041	Can be powered from the X3 battery during transport	current generation Measurement Extensions
M3012A, M3014A, M3015A, M3015B	Cannot be powered from the X3 battery during transport	previous generation Measurement Extensions

WARNING

The Measurement Extensions can only function when they are connected to a Multi-Measurement Module. If the Multi-Measurement Module is removed during monitoring, the measurements from both the Multi-Measurement Module **and** the extension are lost.

Measurements from **any** Measurement Extension connected to an X2, or from a **previous generation** Measurement Extension connected to an X3, are not available when the X2/X3 is running on its own battery power. They are only available when the X2/X3 is powered by external power: when connected to a host monitor, IntelliVue Dock or to the Battery Extension (865297).

Current Generation Measurement Extensions

When the X3 is connected to a host monitor, Cardiac Output (C.O.) measurements can be performed and can be used to calibrate Continuous Cardiac Output (CCO). These stored C.O. results and the calibrated CCO measurement are still available in the X3, when it is disconnected from the host monitor.

867039 Hemodynamic Extension



- 1 Cardiac Output (orange; optional)
- 2 Temperature connector (brown)
- 3 Pressure connector, for one or two pressures (red)
- 4 Connection to Multi-Measurement Module or monitor

The 867039 Hemodynamic Extension adds temperature, two pressures, and optionally cardiac output/PiCCO to the monitor.

867040 Capnography Extension



- 1 Mainstream/sidestream connector CO₂ (gray)
- 2 Cardiac Output (orange, optional)
- 3 Temperature connector (brown, optional)
- 4 Pressure connector, for one or two pressures (red, optional)
- 5 Connection to Multi-Measurement Module or monitor

The 867040 Capnography Extension adds mainstream/sidestream capnography, and optionally temperature, two pressures, and cardiac output/PiCCO to the monitor.

When a capnography extension is connected to an X2 or X3 Multi-Measurement Module with CO₂, the CO₂ from the extension will be automatically deactivated in favor of the one in the X2 or X3. If you prefer to use the CO₂ measurement on the extension, you can activate it via the measurement selection key (see).

PiCCO in the 867040 Capnography Extension is not available in the USA and other territories relying on FDA market clearance.

867041 Microstream CO₂ Extension



- 1 Microstream connector CO₂
- 2 Cardiac Output (orange, optional)
- 3 Temperature connector (brown, optional)
- 4 Pressure connector, for one or two pressures (red, optional)
- 5 Connection to Multi-Measurement Module or monitor

The 867041 Microstream CO₂ Extension adds Microstream capnography, and optionally temperature, two pressures, and cardiac output/PiCCO to the monitor.

PiCCO in the 867041 Microstream CO₂ Extension is not available in the USA and other territories relying on FDA market clearance.

Previous Generation Measurement Extensions

M3012A Hemodynamic Measurement Extension



- 1 Cardiac Output (orange, optional)
- 2 Connection to Multi-Measurement Module
- 3 Pressure connectors (red)
- 4 Temperature connectors (brown)

The M3012A Hemodynamic extension can be connected to an X1, X2, X3 or MMX Multi-Measurement Module to provide the following additional measurements: Temperature, Pressure, an additional Pressure or Temperature, and C.O. and CCO measurements.

The cardiac output measurement is deactivated when the extension is used with an X2 or X3 Multi-Measurement Module unless the X2 or X3 is connected to a host monitor.

M3014A, M3015A, and M3015B Capnography Measurement Extensions

The optional M3014A Capnography extension adds mainstream capnography or sidestream capnography, and optionally one pressure plus either a pressure or a temperature, Cardiac Output and Continuous Cardiac Output to the Multi-Measurement Module.

M3014A



- 1 Pressure connectors (red)
- 2 Temperature connector (brown)
- 3 Mainstream/sidestream connector CO₂
- 4 Cardiac Output connector

The optional **M3015A** Microstream CO₂ extension adds Microstream capnography and optionally either pressure or temperature to the Multi-Measurement Module. The optional **M3015B** Microstream CO₂ extension adds Microstream capnography, two pressures and a temperature to the Multi-Measurement Module.

M3015A

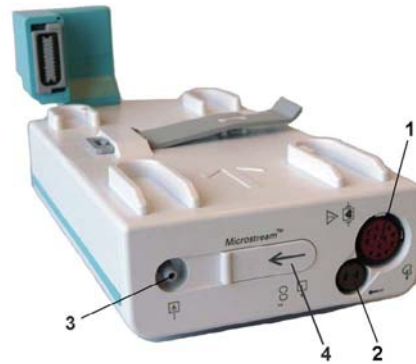

- 1 Pressure connectors (red) - M3015A optional
- 2 Temperature connector (brown) - M3015A optional
- 3 Gas sample outlet
- 4 Microstream connector CO₂ and Inlet

M3015B



When a capnography extension is connected to an X2 or X3 Multi-Measurement Module with CO₂, the CO₂ from the extension will be automatically deactivated in favor of the one in the X2 or X3. If you prefer to use the CO₂ measurement on the extension, you can activate it via the measurement selection key (see).

The cardiac output measurement in the M3014A is deactivated when the extension is used with an X2 or X3 Multi-Measurement Module, even if the X2 or X3 is connected to an external power supply. The cardiac output measurement is only available when the X2 or X3 is connected to a host monitor.

Removing a Measurement Extension

To separate a current generation extension from a Multi-Measurement Module, press the release button and slide the extension away from the Multi-Measurement Module.



To separate a previous generation extension from the Multi-Measurement Module, press the release lever down, and push the Multi-Measurement Module forward.



Tympanic Thermometer (866149)

The tympanic thermometer measures the patient's temperature in the ear using infrared technology. The base station is connected by cable at the rear of the monitor (MIB/RS232 connector).



Gas Analyzers

The **M1013A IntelliVue G1**, **M1019A IntelliVue G5** gas analyzers and the **866173 G7m** gas analyzer plug-in module measure patients' anesthetic and respiratory gases. The following table shows the main features and the patient monitor compatibility for the gas analyzers:

	M1013A IntelliVue G1	M1019A IntelliVue G5	866173 IntelliVue G7m
Number of Gases measured	3	3	3
Number of Agents measured	5 (1 at a time)	5 (2 at a time)	5 (2 at a time)
Automatic Agent ID	n/a	2 out of 5	2 out of 5
Compatibility	IntelliVue MX400/450/500/550/700/800/750/850	IntelliVue MX400/450/500/550/700/800/750/850	IntelliVue MX500/550/700/800/750/850

The **865298 IntelliVue TcG10** measures the partial pressure of oxygen and carbon dioxide transcutaneously in neonates, pediatrics and adults. It is connected to the monitor either via an IntelliBridge EC10 module (with MX500/550/700/800/750/850) or an IntelliBridge EC10 interface board (with MX400/450/500/550).

For all further information about the **M1013A IntelliVue G1** and **M1019A IntelliVue G5** gas analyzers, and the **IntelliVue TcG10**, refer to the Instructions for Use and the Service Guide delivered with them.

The **866173 IntelliVue G7m** gas analyzer module is a plug-in module and is documented in these Instructions for Use and the corresponding Service Guide.

Operating and Navigating

Everything you need to operate the monitor is contained on its screen. Almost every element on the screen is interactive. Screen elements include measurement numerics, waveforms, screen keys, information fields, alarms fields and menus. The typical operator's position is in front of the monitor.

The configurability of the monitor means that often you can access the same element in different ways. For example, you might be able to access an item through its on-screen setup menu, via a hard key, or via a SmartKey.

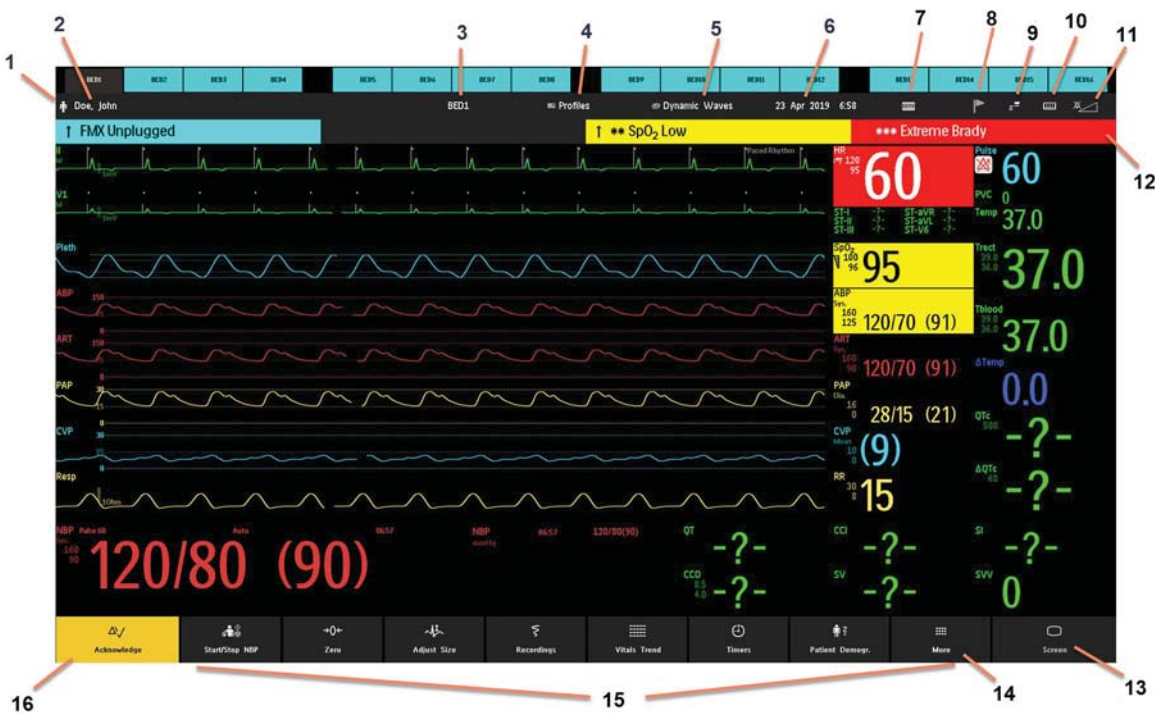

Monitor information line		Other screen elements	
1	patient category symbol	12	alarm status area - shows active alarm messages or Alarms Off symbol when alarms are switched off
2	patient name	13	Screen - close all open menus and windows and return to main screen. or open a window to change to another Screen (when used in the main screen).
3	bed label - gives access to Equipment window	14	More - display more SmartKeys
4	access the Profiles menu or Profile name, depending on configuration	15	SmartKeys - these change according to your monitor's configuration
5	current screen name/enter Change Screen menu	16	Acknowledge - acknowledges all active alarms by switching off audible alarm indicators and lamps permanently or temporarily, if alarm reminder (ReAlarm) is configured on.
6	date and time		
7	operating mode		
8	notifications indicator - selecting this area displays any pending notifications or status messages		
9	network connection indicator (documented in <i>Troubleshooting</i> in the Service Guide)		
10	measurement selection symbol - opens Measurement Selection to resolve label conflicts		
11	adjust alarm volume/level indicator		

If you have an iPC, the iPC symbol will also be displayed in the monitor information line.



Selecting Screen Elements

Select a screen element to tell the monitor to carry out the actions linked to the element. For example, select the Patient Identification element to call up the **Patient Demographics** window, or select the HR numeric to call up the **Setup ECG** menu. Select the ECG wave segment to call up the **ECG Lead** menu.

Note that the space between each line of a menu may be configured to wide or narrow to facilitate your most common method of operation, either touch, or a pointing device such as a mouse.

Using the Touchscreen

Touch a screen element to get to the actions linked to that element. For example, touch a measurement numeric to open the setup menu for that measurement. Touch a wave to enter the setup menu for that wave.

This type of touch screen cannot be operated with a pen or another object; you must use a finger. Touch operation while wearing medical gloves is no problem.

Swiping and Tapping on the Monitor

To scroll through lists, menus, and keys, **swipe** your finger over the Screen, similar to using a smartphone.

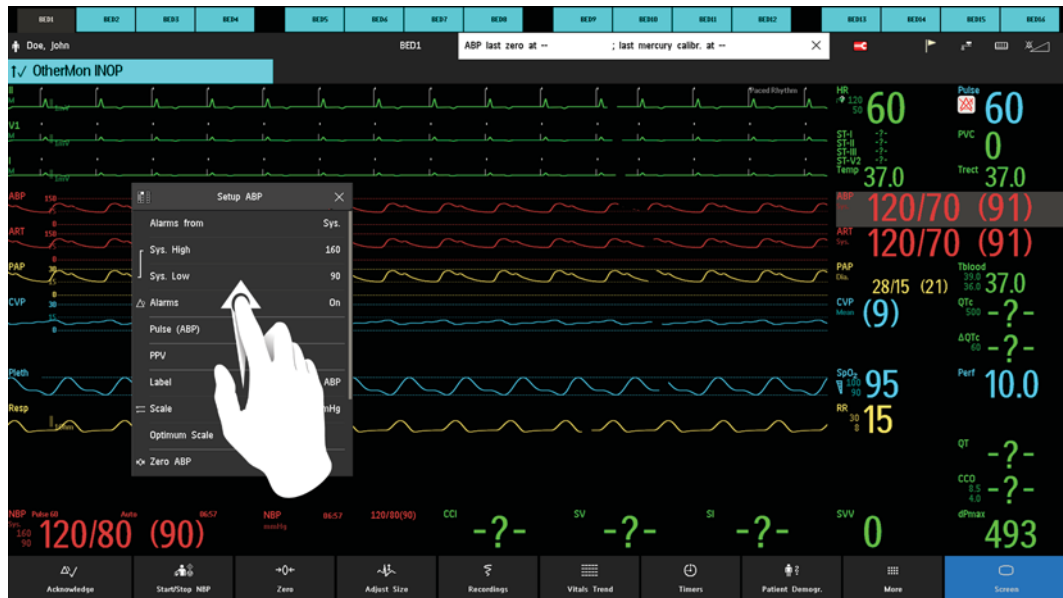

You see that there are more list items or keys available, by the presence of the scroll bar.

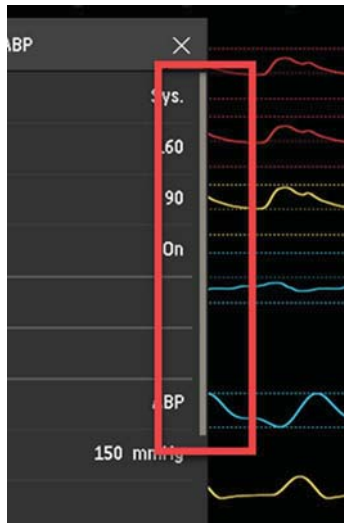

To select an item from a list, or to select a key, **tap** on it with your finger.

To switch to another Screen, swipe with **two** fingers across the Screen to pull it to the right or left, and display the next Screen.

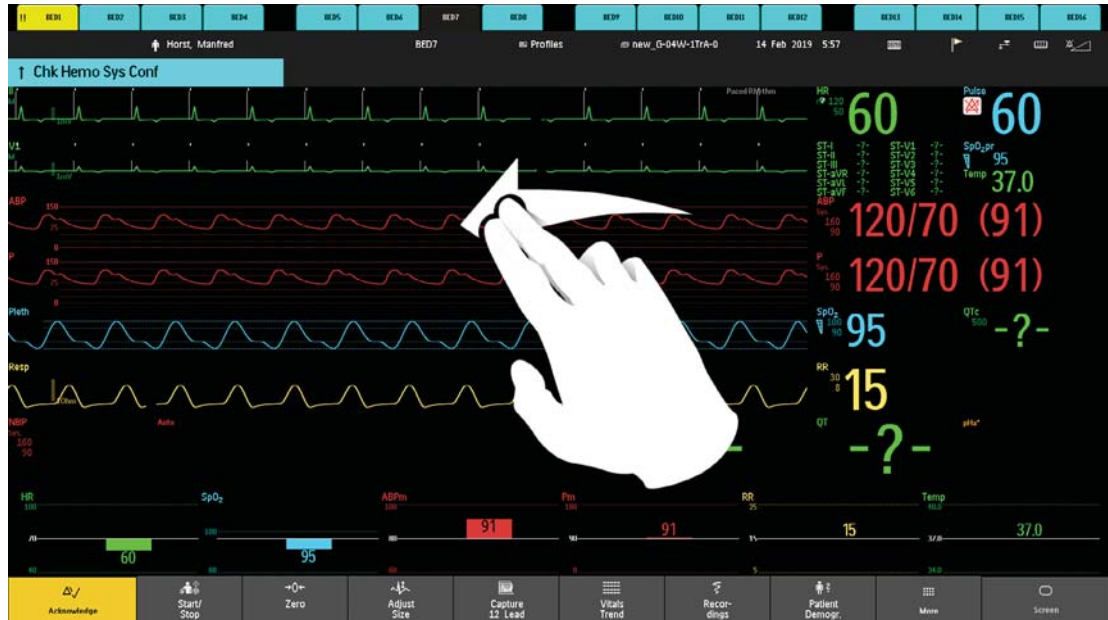

Locking the Touchscreen

You can lock the touchscreen, temporarily disabling touch operation of the monitor.

Touch and hold the **Screen** key - a padlock symbol appears on the key. Touch and hold the key again to unlock the touchscreen, then confirm.

If the touchscreen detects an operating problem, such as fluid on the screen or an unexpected type of contact, it will be automatically locked to prevent accidental operation. When you have checked that nothing is causing unwanted operation, or when you have dried the screen in the case of fluid, you can unlock it again as described above.

Using a Mouse or Trackball

If you are using a mouse or trackball, select screen elements by clicking on them (press and release the left mouse button). While you are moving the mouse, a cursor appears and a highlight shows your current position.

Moving Windows

You can move windows and menus using the Touchscreen or a mouse. To move a window,

- 1 Select the title of the window and keep your finger on the title, or the mouse button pressed.
- 2 Move your finger on the Touchscreen, or move the mouse, to move the window.
- 3 Take your finger off the screen, or release the mouse button, to place the window in the final position.

The new position is only active until the window or menu is closed. Not all locations on the screen can be a target position, a window cannot overlap the monitor info line, the alarms and INOPs or the status line.

NOTE



The SmartKey window cannot be moved.

Using Keys

The monitor has four different types of keys.

Permanent Keys

A permanent key is a graphical key that remains on the screen all the time to give you fast access to functions.

	Acknowledge - acknowledges all active alarms by switching off audible alarm indicators and lamps.
	Screen - close all open menus and windows and return to the main screen. Open a window to change to another Screen (when used in the main screen).

Acknowledge

In the default configuration, there is a large **Acknowledge** key that has two functions:



Acknowledge

- To acknowledge all active alarms and INOPs - touch the key. The **Acknowledge** key is yellow when one or more alarms or INOPs are active.
- To pause or switch off alarms - touch and hold the key until a confirmation window appears.

In the window:

- select the pause time to confirm that alarms should be paused,
or, if your alarms pause setting is **Infinite**,
- select **Yes** to confirm that alarms be switched off.

The alarms off lamp then lights and the corresponding message appears in the alarm status area. See [“Pausing or Switching Off Alarms”](#) on page 70 for more details.

In the alternative configuration, there are two smaller keys each with a single function:



Acknowledge/Pause Alarms

- The **Acknowledge** key, to acknowledge all active alarms and INOPs - it is yellow when one or more alarms or INOPs are active.
- The **Pause Alarms** key, to pause alarms or the **Alarms Off** key to switch alarms off, depending on your configuration.

The alarms off lamp then lights and the corresponding message appears in the alarm status area. See [“Pausing or Switching Off Alarms”](#) on page 70 for more details.

Screen



Screen

The **Screen** key has three functions:

- To return you to the monitoring screen, closing any open windows or menus. The key is blue when any window or menu is open.
- To open a window to change to another Screen (when used in the monitoring screen).
- To *temporarily* disable touchscreen operation of the monitor. Touch and hold the key - a padlock symbol appears on the key. Touch and hold the key again to re-enable touchscreen operation.

SmartKeys

A SmartKey is a configurable graphical key, normally located at the bottom of the main screen. If more than eight SmartKeys are configured, you can access further SmartKeys by selecting the **More** key.

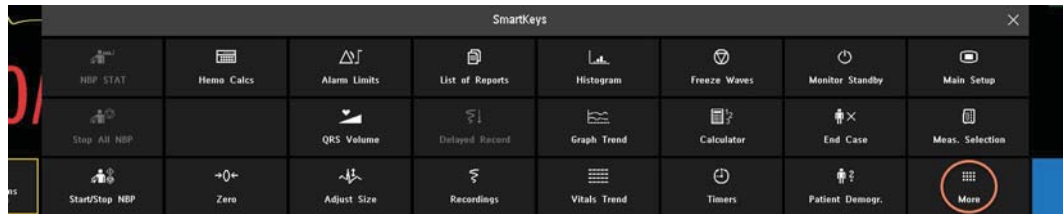

















































If more than one page of SmartKeys is configured you can either swipe with one finger to the left to get to the next set of SmartKeys, or select the **More** key again.



















NOTE

The **Main Setup** SmartKey is always available, either at the bottom of the main screen, or, if more than eight SmartKeys are configured, by selecting the **More** key.

SmartKeys give you fast access to functions. The selection of SmartKeys available on your monitor depends on your monitor configuration and on the options purchased. If you have an integrated PC (iPC) you may also see SmartKeys provided to start applications on the iPC.

	enter profile menu, or revert to default profile		change Screen, or revert to default screen
	show BIS Sensor		previous Screen
	freeze waves		quick admit a patient
	set alarm limits		enter patient demographics menu to admit/discharge/transfer
	change alarm volume		end case to discharge a patient
	change QRS volume		view information for patients in other beds

	enter standby mode - suspends patient monitoring. All waves and numerics disappear from the display. All settings and patient data information are retained.		change screen brightness (not for independent displays)
	review beat labels (annotate arrhythmia wave)		re-learn arrhythmia
	change amplitude (size) of ECG wave		enter cardiac output procedure
	- start/stop manual NBP measurement		start NBP STAT measurement
	- start auto series		stop automatic or STAT NBP measurement and measurement series
	- stop current automatic measurement within series		
	start NBP measurement and measurement series		stop current NBP measurement
	start venipuncture (inflate cuff to subdiastolic pressure)		set the NBP repeat time
	access NBP mode selection and setup, with direct start/stop function		zero invasive pressure transducer
	start a delayed recording		access pop-up recording keys
	access Vital Signs recording function		access Select Waves recording function
	set wide automatic alarm limits		set narrow automatic alarm limits
	access wedge procedure window		access the Loops window
	review vital signs trend		review graph trend
	access event surveillance		access calculations
	access the calculator		access the Drug Calculator
	gas analyzer - exit standby mode		suppress zero for all gas measurements
	unpair equipment and continue central monitoring with the monitor		unpair equipment and continue central monitoring with the telemetry device
	access ST Map application		start 12-Lead Capture (only available if Information Center is connected)
	access remote applications (if Application Server is connected)		access EEG CSA

	access the EEG montage		access aEEG
	access timers		access ProtocolWatch
	set standard or EASI lead placement		switch CO ₂ pump off
	new lead setup		enter data manually
	start/stop car seat assessment record		open the Histogram window
	open Unit Conversion window		start an NMT/PTC measurement cycle (depending on stimulation mode)
	stop an NMT measurement cycle		start NMT calibration
	access patient reports		open the Equipment window
	display external device information		Main Setup - enter main setup menu.
	More - access further SmartKeys		

Hardkeys

A hardkey is a physical key on a monitoring device, such as the zero pressure key on the Multi-Measurement Module or a setup key on a module.

Pop-Up Keys

Pop-up keys are task-related graphical keys that appear automatically on the monitor screen when required. For example, the **Confirm** pop-up key appears only when you need to confirm a change.

Using the On-Screen Keyboard

Use this as you would a conventional keyboard. Enter the information by selecting one character after another. Use the **Shift** and capital **Lock** keys to access uppercase letters. Use the **Back** key to delete single characters, or use the **Clr** key to delete entire entries. Select **Enter** to confirm what you have entered and close the on-screen keyboard.

If a conventional keyboard is connected to the monitor, you can use this instead of or in combination with the on-screen keyboard.

Using the On-Screen Calculator

You can use the on-screen calculator to perform any of the standard operations for which you would normally use a handheld calculator.

- To access the on-screen calculator, select the **Calculator** SmartKey, or select **Main Setup** then **Calculations** followed by **Calculator**.

Contactless User Identification via NFC

User identification functionality is available that allows users to log in at the monitor and provides permissions for specific actions at the monitor. The user that is logged on will be shown in the window border during the SpotCheck procedure.

User permissions allow an identification for the following actions and procedures:

- Review SpotCheck Trends
- Change EWS Protocol

NOTE

- The user ID is not checked or authenticated against a database.
- Always log off when leaving the monitor to ensure that no other user can use your permissions to validate or change date , or acknowledge notifications.

Logging On

To log on to the monitor you need a programmed IntelliVue ProxiTag on your ID card. Hold the ID card close to the NFC Reader (indicated by the NFC Symbol) in the lower right corner of the monitor housing to scan your ID.



A tone will indicate that your ID card has been recognized and "Please wait - Scanning" will be displayed on the screen. Hold the card close to the NFC symbol until the screen message changes to "Finished - Scanning completed". You have now been logged in and can remove your ID card.

NOTE

To avoid accidental touch operation of the monitor, the touch screen will be disabled as long as an ID card is being held close to the NFC reader.

Logging Off

Depending on the configuration,

- You are automatically logged off when:
 - A configured time has passed with no interaction with the monitor
 - You scan your ID card again
- Or you need to manually log off using the **Log On/Off** SmartKey.

Operating Modes

When you switch the monitor on, it starts up in monitoring mode. To change to a different mode:

- 1 Select the **Main Setup** SmartKey.
- 2 Select **Operating Modes** and choose the mode you require.

Your monitor has four operating modes. Some are passcode protected.

- **Monitoring Mode:** This is the normal, every day working mode that you use for monitoring patients. You can change elements such as alarm limits, patient category and so forth. When you discharge the patient, these elements return to their default values. Changes can be stored permanently only in

Configuration Mode. You may see items, such as some menu options or the altitude setting, that are visible but 'grayed out' so that you can neither select nor change them. These are for your information and can be changed only in Configuration Mode.

- **Demonstration Mode:** Passcode protected, this is for demonstration purposes only. You must not change into Demonstration Mode during monitoring. In Demonstration Mode, all stored trend information is deleted from the monitor's memory.
- **Configuration Mode:** Passcode protected, this mode is for personnel trained in configuration tasks. These tasks are described in the Configuration Guide. During installation the monitor is configured for use in your environment. This configuration defines the default settings you work with when you switch on, the number of waves you see and so forth.
- **Service Mode:** Passcode protected, this is for trained service personnel.

When the monitor is in Demonstration Mode, Configuration Mode, or Service Mode, this is indicated by a box with the mode name in the center of the Screen and a symbol in the bottom right-hand corner. Select the mode box in the center of the screen to change to a different mode.

When an X2 or X3 is connected to a host monitor (**Companion Mode** is indicated):

- The monitor in companion mode will adopt the operating mode of the host monitor.
- You cannot change the operating mode at the monitor in companion mode.

Standby Mode

Standby mode can be used when you want to temporarily interrupt monitoring.

To enter Standby mode,

- select the **Monitor Standby** SmartKey or
- select **Main Setup**, followed by **Monitor Standby**.

The monitor enters Standby mode automatically after the End Case function is used to discharge a patient.

Standby suspends patient monitoring. All waves and numerics disappear from the display but all settings and patient data information are retained. A special Standby screen is displayed. This can be configured to a moving image or a blank screen, or to your own custom image. If a temporary patient location has been entered at the monitor or at the Information Center, this location will also be displayed on the Standby screen.

To resume monitoring, touch the screen.

When monitoring is resumed, alarms are paused for 1 minute to allow time to finish plugging in the measurement cables.

If you connect an X2 or X3 that is powered on (and not in Standby) to a host monitor in Standby mode, the host will leave Standby mode. When connected to a host monitor, with both the host and the monitor in companion mode in Standby mode, leaving Standby on the monitor in companion mode will also make the host leave Standby.

Understanding Screens

Your monitor comes with a set of pre-configured Screens, optimized for common monitoring scenarios such as "OR adult", or "ICU neonatal". A Screen defines the overall selection, size and position of waves, numerics and other elements on the monitor screen. You can easily switch between different Screens during monitoring. Screens do **not** affect alarm settings, patient category and so forth.

When you switch from a complex to a less complex Screen layout, some measurements may not be visible but are still monitored in the background. If you switch to a more complex Screen with, for example, four invasive pressure waves but you have only two pressures connected to the monitor, the "missing" two pressures are either left blank or the available space is filled by another measurement.

Switching to a Different Screen

To switch to a different Screen,

- select the current Screen name in the monitor info line, then choose the new Screen from the pop-up list, **or**
- select the **Screen** key, then choose the new Screen from the pop-up list, **or**
- swipe with two fingers across the screen to pull it to the right or left and switch to the next screen, **or**
- select the **Change Screen** SmartKey



and choose the new Screen from the pop-up list.

Changing a Screen's Content

If you do not want to change the entire Screen content, but only some parts of it, you can substitute individual waves, numerics, high-res waves, or trends. Be aware that these changes cannot be stored permanently in Monitoring Mode.

To change the selection of elements on a Screen,

- 1 Select the element you want to change.
- 2 From the menu that appears, select **Change Wave**, **Change Numeric**, or **ChangeHiResTrend**, and then select the wave or numeric you want, or select the high-resolution trend wave you want from the list of available waves.

If you do not see **Change Numeric** in the menu, this Screen may be configured to always display the numeric beside its wave. Changing the wave will automatically change the numeric.

The changed Screen is shown with an asterisk in the monitor info line.

In the **Change Screen** menu, the changed Screen is shown linked to the original Screen and marked with an asterisk.

Up to three modified Screens can be accessed via the **Change Screen** menu.

To recall Screens, either

- select the name of the Screen in the **Change Screen** menu
- or
- use the previous arrow at the top of the **Change Screen** menu to move back in the Screen history. The ten most recently-used Screens including up to three modified Screens can be accessed.

After a patient discharge, the monitor's default Screen is shown. Modified Screens are still available in the **Change Screen** menu.

If the monitor is switched off and then on again, modified Screens are erased from the monitor's memory and cannot be recalled. If a modified Screen was the last active Screen when the monitor was switched off, it is retained (unless **Automat. Default** is configured to **Yes**).

Viewing Notifications

There are various types of notifications that can be generated by the monitor.

- **Status messages** inform about a current state or condition, for example, **Local Recorder door open**.
- **Prompt messages** inform about an action that is required from the user, for example, **Ready for new measurement**.
- **Clinical notifications** inform about clinically relevant events that are not alarms, for example, an early warning score or an alarm advisor.

When a notification is triggered, a message pops up on the screen for a short time. In addition, a notification symbol appears in the status area of the screen (also called the system tray).



Example of an early warning score notification symbol



Alarm advisor notification symbol



Status and prompt notification symbol

By selecting the symbol you can open the **Notifications** window.

Notifications Window

In the **Notifications** window, you see a list of all notifications currently active on the monitor. Each notification includes the corresponding notification symbol (see “[Viewing Notifications](#)” on page 47), a text message, and a symbol indicating the acknowledgment status.



New



Seen



Acknowledged or resolved

When you select a notification,

- the status changes to "seen".
- you may see more details, depending on the source.
- a pop-up key may appear for you to acknowledge receipt of the notification. Some prompt and status notifications cannot be acknowledged and some notifications come from clinical applications that manage acknowledgment and resolution in their own windows.

Using the XDS Remote Display

Using the IntelliVue XDS Software it is possible to view an independent monitor screen on an external display. Depending on the configuration you can also operate the monitor from the external display.

For more details, including limitations and restrictions, refer to the IntelliVue XDS Software Instructions for Use.

Using the Visitors Screen

If a visitors Screen is configured for your monitor, you can use it to clear the screen of all waves and numerics but continue to monitor the patient with active alarms and trend storage at the bedside and Information Center. When the visitors Screen is selected, no automatic pop-up windows such as the Other Bed window or the ProtocolWatch window will be displayed. You can change the name of the visitors Screen in Configuration Mode.

- To activate this Screen, select the Screen name in the monitor info line to open the **Change Screen** menu, then select the name of the visitors Screen configured for your monitor from the list of available Screens.

To select a Screen with waves and numerics again,

- Select the name of the visitors Screen, below the clock, to open the **Change Screen** menu and select a different Screen to show waves and numerics again.

Understanding Profiles

Profiles are predefined monitor configurations. They let you change the configuration of the whole monitor so you can adapt it to different monitoring situations. The changes that occur when you change a complete profile are more far reaching than those made when you change a Screen. Screens affect only what is shown on the display. Profiles affect all monitor and measurement settings.

The settings that are defined by Profiles are grouped into three categories. Each category offers a choice of 'settings blocks' customized for specific monitoring situations. These categories are:

- **Display** (screens)

Each profile can have a choice of many different predefined screens.

If you are using a second display, each display can have its own individual screen selection. When you change the profile, the screen selection configured for the new profile becomes active.

- **Measurement Settings**

Each profile can have a choice of different predefined measurement settings. These relate directly to individual measurements, for example, measurement on/off, measurement color, alarms limits, NBP alarm source, NBP repeat time, temperature unit (°F or °C), pressure unit (mmHg or kPa).

- **Monitor Settings**

Each profile can have a choice of different predefined monitor settings. These relate to the monitor as a whole; for example, display brightness, alarms off/paused, alarm volume, QRS tone volume, tone modulation, prompt tone volume, wave speed, resp wave speed, pulse source.

You can change from one complete profile to another or swap individual settings blocks (display/monitor settings/measurement settings) to change a subset of a profile. Changes you make to any element within the settings blocks are not saved when you discharge the patient, unless you save them in Configuration Mode.

Depending on your monitor configuration, when you switch on or discharge a patient the monitor either continues with the previous profile, or resets to the default profile configured for that monitor.

WARNING

- If you switch to a different profile, the patient category and paced status normally change to the setting specified in the new profile. However some profiles may be set up to leave the patient category and paced status unchanged. Always check the patient category, paced status, and all alarms and settings, when you change profiles.
 - If your monitor is configured to show the profile name in the info line at the top of the screen, be aware that individual settings may have been changed by other users or by settings synchronization since the profile was loaded. Hence settings may be different than implied by the profile name.
-

When you leave Demonstration Mode, the monitor uses the default profile.

Swapping a Complete Profile

- 1 Select **Profiles** in the monitor info line, or select the **Profiles** SmartKey.



- 2 Select the **Profile Details** pop-up key.
- 3 In the **Profiles** menu, select **Profile**.
- 4 Choose a profile from the pop-up list.
- 5 Confirm your selection.

Swapping a Settings Block

- 1 Select the Profile in the monitor info line.
- 2 Select the **Profile Details** pop-up key.
- 3 In the **Profile Details** menu, select **Display** or **Measmnt.Settings** or **Monitor Settings** to call up a list of the settings blocks in each category.
- 4 Choose a settings block from the list.
- 5 Confirm your selection, if required.

Default Profile

Your monitor has a default profile that it uses when you leave Demonstration mode, or when you discharge a patient. This profile is indicated by a diamond shaped symbol.

Locked Profiles



Some profiles are locked, so that you cannot change them, even in Configuration Mode. These are indicated by this lock symbol.

Understanding Settings

Each aspect of how the monitor works and looks is defined by a setting. There are a number of different categories of settings, including,

Screen settings, to define the selection and appearance of elements on each individual Screen

Measurement settings, to define settings unique to each measurement, for example, high and low alarm limits

Monitor settings, including settings that affect more than one measurement or Screen and define general aspects of how the monitor works, for example, alarm volume, reports and recordings, and display brightness.

You must be aware that, although many settings can be changed in Monitoring Mode, permanent changes to settings can only be done in the monitor's Configuration Mode.

All settings are reset to the stored defaults:

- when you discharge a patient
- when you load a Profile
- when the monitor is switched off for more than one minute (if **Automat. Default** is set to **Yes**).

Changing Measurement Settings

Each measurement has a setup menu in which you can adjust all of its settings. You can enter a setup menu:

- via the measurement numeric - select the measurement numeric to enter its setup menu. For example, to enter the **Setup ECG** menu, select the HR (heart rate) numeric.
- via the Setup hardkey (on plug-in modules) - press the Setup hardkey on the module front.
- via the **Main Setup** permanent key - if you want to setup a measurement when the measurement is switched off, use the **Main Setup** permanent key and select **Measurements**. Then select the measurement name from the pop-up list. With this permanent key you can access any setup menu in the monitor.
- via the Measurement Selection key.

This guide always describes the entry method using the setup menu. But you can use any method you prefer.

Switching a Measurement On and Off

When a measurement is off, its waves and numerics are removed from the monitor's screen. The monitor stops data acquisition and alarming for this measurement. A measurement automatically switches off if you disconnect its module or Multi-Measurement Module. If you disconnect a transducer, the monitor replaces the measurement numeric with question marks. If you acknowledge the resulting INOP, the measurement is switched off. Also if you pause or switch off alarms, the measurement may be switched off completely, depending on your configuration.

- 1 Enter the measurement's setup menu and select the measurement.
- 2 Select the measurement name to switch between on and off. The screen display indicates the active setting.

Switching Numerics On and Off

For some measurements, such as EEG, you can choose which numerics to view on the screen.

In the measurement's setup menu, select the numeric name to toggle between on and off.

For example in the **Setup EEG** menu, select the EEG numeric name to toggle between on and off.

Adjusting a Measurement Wave

To quickly adjust wave-related measurement settings (such as speed or size), select the measurement wave itself. This displays the measurement wave menu, which has only wave-related measurement settings.

Temporary Availability of Functionality

Certain functionality options that have not been purchased for your monitor can be tested on a "free trial" basis. Selecting the functionality and starting the 30-day trial period must be done in Configuration Mode (see the Configuration Guide for details).

If a free trial has been set up and started on your monitor, the selected functionality is available to you in the normal way. When the trial period ends, the functionality is no longer available on the monitor. The next time the monitor is restarted, the functionality is deactivated and a message appears stating that the free trial has ended.

To check if a free trial is running, or see which functionality is available for a free trial:

- 1 Select **Main Setup**, then **Revisions**, and **Free Trial**. The **Setup Free Trial** menu opens.
- 2 Check at the top of the menu whether a free trial is running or not.
- 3 Check in the list in the lower part of the menu, which functionality is available for free trial.

Changing Wave Speeds

Lowering the wave speed compresses the wave and lets you view a longer time period. Increasing the speed expands the waveform, giving you a more detailed view.

The monitor distinguishes three groups of wave speed settings:

- **RespiratorySpeed**, for all respiratory waves: CO₂, anesthetic agents and O₂
- **EEG Speed**, for all EEG and BIS waves
- **Global Speed**, for all waves not included in the other two groups.

Changing the Wave Group Speed

The wave speed group setting defines the speed of all the waves in the group.

To change the wave speed of a wave speed group,

- 1 Select **Main Setup**, then select **User Interface**
- 2 Select **Global Speed**, **RespiratorySpeed**, or **EEG Speed** as required
- 3 Select a value from the list of available speeds.

Changing Wave Speed for a Channel

To change the wave speed of an individual wave channel,

- 1 Enter the Wave menu for a measurement by selecting its wave.
- 2 Select **Change Speed**.
- 3 To set the speed to the wave group speed, select **RespiratorySpeed**, **EEG Speed**, or **Global Speed**.

To set an individual channel speed, select a numeric value from the list of available speeds. This overrides the wave group speed setting and set the speed for the individual wave channel on the monitor Screen. The wave channel speed is independent of the wave (label) depicted in the channel, if you change the wave, the new wave will retain the set channel speed.

Freezing Waves

You can freeze waves on the screen and measure parts of the wave using cursors. The waves are frozen with a history of 20 seconds so that you can go back and measure what you have seen.

Freezing An Individual Wave

To freeze a wave,

- 1 Enter the Wave menu for the measurement by selecting the wave on the screen.
- 2 Select **Freeze Wave**.

The realtime wave is replaced with the frozen wave.

Freezing All Waves

To freeze all waves on the screen,

- 1 Select the **Freeze Waves** SmartKey.



All realtime waves are replaced with frozen waves.

Measuring Frozen Waves

To measure a frozen wave,

- 1 Select the frozen wave.
If you are using touch, this automatically positions the vertical cursor. The cursor can be repositioned by touching the required point on the wave, **or**
- 2 Use the right/left arrow keys to move the vertical cursor.
The vertical cursor moves through the time axis and the current value is displayed next to the cursor.
- 3 Use the up/down arrow keys to activate and move the horizontal cursor.
The horizontal cursor measures the wave value, which is displayed above the cursor line. If the wave is a pressure wave, the cursor value can be stored as a systolic, diastolic or mean pressure value; if the pressure wave is a PAP wave it can also be stored as a PAWP value; for pressure waves P, P1 to P8 it can also be stored as an IAP value. The stored value appears in the trend database as a manually entered value.

Changing The Wave Speed

Lowering the wave speed compresses the wave and lets you view a longer time period. Increasing the speed expands the waveform, giving you a more detailed view.

To change the wave speed,

- 1 Select the frozen wave.
- 2 Select **Change Speed**.
- 3 Select a speed from the list.

Updating The Frozen Wave

To update the wave, that is freeze the current wave,

- 1 Select the frozen wave.
- 2 Select **Freeze Again**.

Releasing Frozen Waves

To release frozen waves,

- 1 Select a frozen wave.
- 2 Select **Unfreeze Waves**.

All frozen waves are released.

Using Labels

Every measurement associated with a monitor is identified by a unique label. You may have more than one instance of some measurements, for example pressure, being used simultaneously. The monitor uses the labels to distinguish between them. The default settings defined in the profile (such as measurement color, wave scale, and alarm settings) are stored within each label. When you assign a label to a measurement, the monitor automatically applies these default settings to the measurement. The labels assigned are used throughout the monitor, in reports, recordings, and in trends.

Changing Measurement Labels (e.g. Pressure)

To change a measurement label of a measurement with multiple labels (e.g. invasive pressure or temperature),

- 1 Enter the wave menu of the measurement.
- 2 Select **Label**.
- 3 Choose a label from the list.

The monitor automatically applies the scale, color, etc. settings stored in the Profile for the label you select. You can change scale settings in Monitoring Mode, but color can only be changed in the monitor's Configuration Mode.

Any labels already being used in the monitor are shown "grayed-out" in the list and cannot be selected.

About Label Sets

Your monitor may be configured to use a **Restricted** or **Full** label set. The **Full** label set provides extra labels for Pressure and Temp. See the sections on Pressure and Temperature in these Instructions for Use for more information.

If you connect a Multi-Measurement Module from a monitor using a **Full** label set to an IntelliVue monitor using a **Restricted** label set, any additional labels switch to labels available in the target monitor. This may cause a label conflict with other monitored measurements.

Be aware that connecting a monitor using the **Full** label set to an Information Center with certain software revisions may affect the availability of measurement information from the additional labels on the Information Center. See the Information Center documentation and your monitor's Configuration Guide for information on label set compatibility.

Resolving Label Conflicts

Each label must be unique, that is, it can only be assigned once. You cannot monitor two pressures labeled "ICP" at the same time. If you need to use two identical pressures, you must assign different labels to them, for example, P and ICP.

Measurement labels are stored in the measurement device (module or Multi-Measurement Module). If you try to use two measurement devices that have identical labels, this causes a label conflict in the monitor.



Measurement selection key with question marks indicating a label conflict.

Depending on your configuration, the monitor will either

- resolve the conflict automatically, by assigning a new, generic label to the most recently connected conflicting label (e.g. a second FAP label could be changed to ABP)
- display the **Measurement Selection** window automatically for you to resolve the conflict
- take no action, you must enter the **Measurement Selection** window and resolve the conflict.

All the currently available measurement devices, for example Multi-Measurement Module, Measurement Extensions, measurement modules, Gas analyzers, devices connected to a host monitor and manually

entered measurements (marked , are depicted in the **Measurement Selection** window.

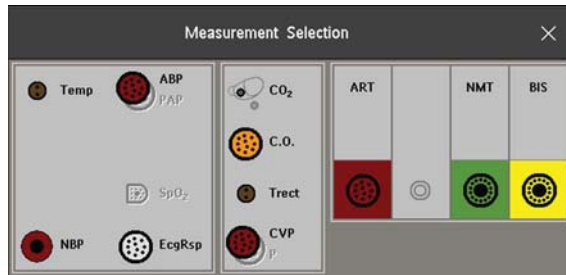

De-activated devices are grayed-out (here the SpO₂ measurement on the left)

Any measurement labels causing a label conflict are shown in red. If a measurement device is connected but currently unavailable, for example, because it was deactivated due to a label conflict, the device is shown grayed-out.

WARNING

When an X2 or X3 with an active measurement, say SpO₂, is connected to a host monitor with the same measurement already active, the SpO₂ measurement on the X2 or X3 is deactivated and the **Meas. Deactivated INOP** is displayed. The measurement can only be reactivated if the X2 or X3 is disconnected from the host monitor. The label conflict can be resolved on the host monitor like any other label conflict.

To resolve a label conflict:

- 1 Select the measurement selection key or select **Main Setup**, then **Meas. Selection** to display the **Measurement Selection** window.
- 2 Select the device whose label you want to correct.
- 3 Use the measurement selection pop-up keys to resolve the conflict. Select either:
 - **Change Label:** to assign a different label to the conflicting label.
 - **Activate:** to activate the highlighted measurement and deactivate the blinking measurement. This requires confirmation.
 - **De- Activate:** to disable the conflicting device. It retains its label for future use but becomes invisible to the monitor, as though it had been unplugged. When the device has been deactivated the question marks under the measurement selection key will be replaced by XXX.
 - **Setup <Measurement Label>:** to enter the Setup menu for the measurement and change the conflicting device's label to a different label.
 - **Modify Driver** (IntelliBridge only): - to modify the device driver setup to disable the conflicting device's label.

Label Compatibility

When a new measurement is introduced, or new labels for an existing measurement, these labels will not be shown on older Information Centers, and consequently not on the Overview screen sourced from the Information Center.

When a patient is transferred from a monitor with these new labels to one with an older software revision, the labels will be replaced with a generic label for that measurement. The settings for that generic label will then be used.

If it is critical that the measurement labels are available at the Information Center and after transfers, the older monitors and the Information Center must be upgraded to the appropriate software revision.

Entering Measurements Manually

You can enter values into the monitor that have been measured with other equipment or manually (for example, manual temperatures, lab values). These values are then stored in the database, included in trends and reports, and passed on to the Information Center and central charting systems. There is no alarm functionality for manually entered measurements.

To enter values,

- 1 Select the **Enter Values** SmartKey or select **Main Setup** then select **Enter MeasValues**.
- 2 Select the measurement you want to enter values for. The Edit window will open.
- 3 If the measurement is switched off, switch it on by selecting the label.
- 4 Select **Value** and enter the value.
- 5 Select **Date/Time** to enter the date and time for the value. The default is always the current date and time.
- 6 For compound labels, for example **ABPs**, **ABPd** and **ABPm**, select the **Format** field to select whether all values are required or a single value.
- 7 Select **Save**.

When a manually entered value has been configured to display as a numeric on the screen, you can also enter a new value for this measurement by selecting the numeric, then selecting **Enter MeasValues**.

Manually entered measurement values are marked with a * on the display, in trends, and so forth. Each measurement has a defined measurement interval after which a value becomes invalid (no value is then displayed). Values can be entered up to two hours after they have been measured or up to the measurement interval, if this is shorter.

The list of measurement labels which appears in the **Enter Measurement Values** window is set in Configuration Mode.

Switching Manually Entered Measurements On and Off

To switch a manually entered measurement on or off,

- 1 Select the **Enter Values** SmartKey or select **Main Setup** then select **Enter MeasValues**.
- 2 Select the measurement you want to switch on or off.
- 3 Select the measurement label field to switch between **On** and **Off**.

Setting Up the Synchronization Output (with MMX or X3 only)

NOTE

To set up the synchronization output when using an X2 or an MMS you must go into Configuration Mode. See the Configuration Guide for details.

The monitor has a synchronization output interface. The interface provides measured physiological signals, in the form of an electrical signal in real time, to external medical devices. To use these signals, the external device must be connected by cable to the output on the monitor.

There are two output channels. You can change different settings on the monitor for each channel.

- 1 Select **Main Setup**, then **Measurements**.
- 2 Select **SyncOut**. The **Setup SyncOut** window opens.

For channel 1, the **Source** is always ECG, **Primary Lead**, and the **Signal Type** is **Analog Wave**. You can set the signal gain for the ECG wave output:

- 1 Select **Mon-1 (ECG)**, to select channel 1 that outputs the ECG wave.
- 2 Select **ECG Out Gain** and select a value for the gain from the list.

For channel 2, the **Source** is always ECG, **Primary Lead**. You can select the **Signal Type**, and further settings that depend on the **Signal Type**.

- 1 Select **Mon-2 (ECG)**.
- 2 Select **Signal Type**, then select **Analog Wave** or **Sync Pulse**.
If you select **Analog Wave**, you can set the signal gain for the ECG wave output as described above for channel 1. If you select **Sync Pulse**, you can set the sensitivity, and whether a pulse marker is shown:
- 3 Select **Sensitivity** and select a sensitivity level from the list.
- 4 Select **Pulse Marker** and set to **On** or **Off**, as required.

Changing Monitor Settings

To change monitor settings such as brightness, or QRS tone volume, select the **Main Setup** permanent key and then select **User Interface** to enter a submenu where you can change these settings.

Adjusting the Screen Brightness

To adjust the brightness:

- 1 Select the **Brightness** SmartKey.



- 2 Select the appropriate setting for the screen brightness. 10 is the brightest, 1 is the least bright. **Optimum** is suitable for most monitoring locations and optimizes power usage for battery powered monitors.

The monitors can be configured to automatically adapt the screen brightness to the ambient light conditions. The range within which this adaptation is made is determined by the setting made with the **Brightness** SmartKey.

Your monitor may be configured with a lower brightness for Standby mode and also (for battery powered monitors) for transport to conserve battery power. These settings can only be changed in the monitor's Configuration Mode.

If you are using a monitor with an external display, the **Brightness** SmartKey does not adjust the brightness of this display. Refer to the documentation supplied with the external display for instructions.

Setting the Date and Time

- 1 Select the **Date, Time** screen element from the monitor's info line to enter the **Date, Time** menu.
- 2 Select, in turn, the **Year, Month, Day, Hour** (in 24 hour format, only) and **Minute** as necessary. Select the correct values from the pop-up list.
- 3 Select **Store Date, Time** to change the date and time.

If your monitor is connected to an Information Center, the date and time are automatically taken from this. Once it is set, the internal clock retains the setting even when you switch off the monitor.

WARNING

Changing the date or time will affect the storage of trends and events.

Checking Your Monitor Revision

- 1 Select **Main Setup** then select **Revisions** to open the **Monitor Revision** menu.
- 2 Select the correct device from the device pop-up keys.
- 3 From the **Monitor Revision** menu, select the monitor component for which you need revision information.

Getting Started

Once you understand the basic operation principles, you can get ready for monitoring. We also recommend working through the E-Learning Education Programs for self-training before using the monitor (available at the Philips Learning Center, English only).

Inspecting the Monitor

WARNING

If the monitor or mounting hardware is mechanically damaged, or if it is not working properly, do not use it for any monitoring procedure on a patient. Contact your service personnel.

- 1 Before you start to make measurements, carry out the following checks on the monitor including all connected Multi-Measurement Modules, modules, or Measurement Extensions.
 - Check for any mechanical damage.
 - Check all the external cables, plug-ins and accessories.
- 2 Plug the power cord into the AC power source.
- 3 Check all the functions of the instrument that you need to monitor the patient, and ensure that the instrument is in good working order.

Setting up the Modules

- 1 Decide which measurements you want to make.
- 2 Connect the required modules, Multi-Measurement Modules, or Measurement Extensions.
- 3 Check that you have the correct patient cables and transducers plugged in. The connectors are color-coded to the patient cables and transducers for easy identification.

Switching On

Press the monitor on/off switch for one second. The monitor performs a self test during which all lamps will light up and a tone will be sounded, and is then ready to use. If you see a message such as **CO₂ Sens Warmup** wait until it disappears before starting to monitor that measurement.

Connected devices usually take their power from the monitor. External devices such as gas monitors and those connected via IntelliBridge have their own power switches.

Power On/Power Off Behavior

The general rules determining the behavior of the monitor when connected to, or disconnected from power are as follows:

- A monitor that was switched on prior to a temporary power loss switches on again when power is restored.
- A monitor that was switched off prior to a temporary power loss remains off when power is restored.
- A Multi-Measurement Module switches on automatically when connected to a running host monitor.
- When an X2 or X3 is disconnected from a running host monitor, the X2 or X3 continues to run without interruption on battery power.

Starting Monitoring

After you switch on the monitor,

- 1 Admit your patient to the monitor.
- 2 Check that the profile, alarm limits, alarm and QRS volumes, patient category and paced status and so forth are appropriate for your patient. Change them if necessary.
- 3 Refer to the appropriate measurement chapter for further details of how to perform the measurements you require.

Disconnecting from Power

The on/off switch does not disconnect the monitor from the AC power source. To disconnect, unplug the power cable.

Monitoring After a Power Failure

- A monitor that was switched on prior to a temporary power loss switches on again when power is restored.
- A monitor that was switched off prior to a temporary power loss remains off when power is restored.

If the monitor is without power for **less** than one minute, monitoring will resume with all active settings unchanged.

If the monitor is without power for **more** than one minute, the behavior depends on your configuration. If **Automat. Default** is set to **Yes**, the default profile will be loaded when power is restored. If **Automat. Default** is set to **No**, all active settings are retained, if power is restored within 48 hours. The **Automat. Default** setting is made in Configuration Mode.

Networked Monitoring

You can connect your monitor to an Information Center on a network, using one of the following interfaces:

- Standard wired LAN
- Wireless LAN

WARNING

Only connect patient monitors to networks that conform to the network installation instructions provided by Philips for your system.

It is possible to assign additional monitoring equipment and a telemetry device to the same patient, resulting in the information from multiple devices being combined in one sector at the Information Center. (See “When Multiple Equipment is Used for One Patient” on page 137 and “Using a Telemetry Device and a Monitor (PIIC only)” on page 337.)

In wireless networks, interference from other radio sources or the mis-configuration or malfunction of wireless network infrastructure components can lead to data loss. Take this into account when determining monitoring needs for a patient.

If your monitor is connected to a network, a network symbol is displayed in the upper left corner next to the bed label. To see details about the Care Group, the monitoring equipment, and technical information about the network, select the bed label in the monitor info line.

Be aware that some network-based functions may be limited for monitors on wireless networks in comparison to those on wired networks.

Printout functionality and data export are not guaranteed when using a standard hospital network.

Using Remote Applications

With the appropriate connections, you can access pre-configured applications made available by your hospital. The applications are hosted remotely and can be displayed and operated on the patient monitor screen. The portal technology allows information access through a web browser, terminal emulation, or served applications.

The applications are hosted on a Citrix® XenApp® server or you connect to PIC iX Web/PIIC Web.





The applications available depend on the server configuration.

To display remote applications on the monitor,

- 1 In the **Main Setup** menu, select **Remote Applics**, or select the **Remote Applics** SmartKey.
- 2 Select the required application from the pop-up list of available applications.
- 3 Operate the application with your preferred monitor input device: touchscreen, keyboard or mouse.

The appearance of an application on the monitor may be different than on a PC or another operating system. The display of an application with clinical content may not be suitable for diagnostic use, due to the limited resolution of the monitor display.

Remote Application Pop-up Keys

Pop-Up Keys	Selecting this pop-up key lets you....
Minimize	minimize the Remote Application window; the session continues running in the background. Select the Remote Application symbol to show the window at full size again.
Keyboard	start the screen keyboard on the monitor.
	move to the previous or next page.
	zoom in.
	zoom out.
Refresh 	update the content of the Remote Application window.
Change Appl.	select a new application.
Close Appl.	close the Remote Application session.

Using the Integrated PC

If your monitor has the optional integrated PC (iPC), you can run applications on the iPC. The applications display data on the monitor's display (or on a second independent display) that is generated on and retrieved from the iPC or externally.

For details about applications, refer to the IntelliVue XDS Application Instructions for Use.

The monitor runs independently of the iPC, and vice versa.

WARNING

- Some clinical applications may show outdated information or data from another patient. Be aware that some of the data on your patient monitor display may not always be from your patient.
 - Applications running on the iPC cannot act as a primary alarming device and cannot be relied upon for alarm notification. There may be no audible or visible indications apart from what is shown on the screen and any data shown may be delayed.
-

CAUTION

When you install any software on the iPC you are responsible for ensuring that the resulting system complies with all relevant local regulations.

Starting the iPC

Your monitor may be configured to have the iPC start up automatically when the monitor is switched on. If not:

- 1 Select **Main Setup** then **Internal PC**.
- 2 In the **Internal PC** menu, select **Switch PC on** to start the iPC.

Viewing the iPC Desktop on the Monitor Display

If the Desktop is not displayed on the monitor display:

- 1 Select the iPC key , or
- 2 Select **Main Setup**, **Internal PC**, then **Show PC Window**.

To hide the Desktop again, select **Main Screen**.

There are special iPC screens available that use the full height of the screen for the iPC Desktop. The monitoring screen content is then arranged on the right side of the screen. Such iPC screens may be loaded automatically when the iPC key is selected. In this case the **Main Screen** key is replaced by a **Previous Screen** key, to give you a fast and easy method to switch back and forth between the iPC screen and the regular screen.

Adjusting the iPC Audio Volume

The Audio from the iPC is normally configured to be off. However, your monitor may have the iPC audio configured on for use with specific PC applications.

WARNING

Always minimize the iPC audio volume or mute it completely when it is not needed for an iPC application. This will avoid iPC tones distracting from or masking tones from the monitor.

Using Input Devices with the iPC and Monitor

You can connect input devices such as a mouse, trackball and keyboard to the rear of the patient monitor (using the **left** hand row of USB connectors) and use them for input to the monitor. Correspondingly you can connect input devices to the rear of the patient monitor (using the **right** hand row of USB connectors) or to the front USB connector and use them for the iPC. Input devices connected to the iPC can also be shared with the patient monitor. Sharing input devices and touchscreen input requires a specific software application; refer to the IntelliVue XDS Software Instructions for Use for details.

If the iPC is switched off when input devices are shared, any input devices connected to it will not be available for use with the monitor.

Shutting the iPC Down

The iPC will be shut down automatically when the monitor is switched off.

If you want to shut down the iPC when the monitor is on,

- 1 Select **Main Setup** then **Internal PC**.
- 2 In the **Internal PC** menu, select **Switch PC off**.

If there is a problem with the shutdown, and you need to switch off the iPC manually,

- 1 Select **Main Setup** then **Internal PC**.
- 2 In the **Internal PC** menu, select **Force PC off** to force the iPC to power down.

Special Situations at Shutdown

- If you switch the monitor off and then on again immediately, the iPC will continue running and will not be shut down.
- In some situations, shutting down the iPC can take a little time. The monitor will go into Standby mode until the shutdown is complete. By touching the touchscreen, you can bring the monitor back into operating mode. If you do this, the iPC will restart again after its shutdown is complete.
- If the shutdown cannot be completed within a certain time, a window will open giving the reason: for example, that a file has not been saved, or that updates are being installed. You can then decide whether to wait (for example, in the case of the updates) or to take action (for example by saving the unsaved file). You will also have the option to force shutdown, if necessary.
- If the monitor on/off switch is pressed for longer than 4 seconds, the monitor switches off and the iPC is forcibly shut down.

Using Your Monitor with an X2 or X3 in Companion Mode

When you connect an X2 or X3 in companion mode to a host monitor, an integrated system is formed for monitoring a single patient. The following general observations and considerations apply to such a system:

- The host monitor is the "master" of the system, and you have full control over all the system's operation only via the host monitor.
- Functions you can operate on a monitor in companion mode are restricted to measurements originating in that device. If you try to operate controls that are disabled, you are prompted by the message **Not available in Companion Mode**.
- Depending on how it is configured, your host monitor can determine whether the user interface of a connected monitor in companion mode is completely disabled or not, and what is displayed on the screen (a standard main screen, or a blank screen indicating **Companion Mode**).

This is controlled by two monitor settings that are applied to the monitor in companion mode on connection. You can change the settings in Configuration Mode.

- Global settings such as line frequency, QRS sound and ECG lead colors from the host monitor, are applied to the monitor in companion mode on connection. When disconnected from the host, the monitor in companion mode re-applies its own global settings.
- No audible alarms are available on a monitor in companion mode when connected to a host monitor. The only visual alarm indication is provided by the alarm lamps which are controlled by the host monitor. Alarms become active again as soon as the monitor in companion mode is disconnected from the host monitor.
- The host monitor is the master of all ADT information. ADT operations on the monitor in companion mode are disabled, and any pending actions on the monitor in companion mode (for example, admit or end case) are canceled.
- The date and time of the monitor in companion mode is synchronized with that of the host monitor.
- An X2/X3 switches on automatically when connected to a running host monitor.
- When an X2/X3 is disconnected from a running host monitor, the X2/X3 continues to run without interruption on battery power.
- When an X2/X3 is used with host monitors having different software revisions, be aware that functionality set up in a monitor with a newer revision will disappear when the X2/X3 is connected to a monitor with an older revision without that functionality. If you work in a mixed software environment, inform yourself about the differences between revisions by referring to the What's New chapter.
- A host monitor may have **more** or **less** optional functionality than an X2/X3.
 - When the X2/X3 is connected to the host monitor, the optional functionality of the host is available for monitoring.
 - When the X2/X3 is disconnected from the host monitor, its own optional functionality is available.

Depending on which device has the higher functionality, you will experience a loss of some optional functionality when connecting or disconnecting the X2/X3 to or from the host monitor. For example, when an X2/X3 with the basic arrhythmia option is disconnected from a host monitor with the enhanced arrhythmia option, **** AFIB** alarms will no longer be generated.

Alarms

The alarm information here applies to all measurements. Measurement-specific alarm information is discussed in the sections on individual measurements.

The monitor has two different types of alarm: patient alarms and INOPs.

Patient Alarms

Patient Alarms are red and yellow alarms. A red alarm indicates a high priority patient alarm such as a potentially life threatening situation (for example, asystole). A yellow alarm indicates a lower priority patient alarm (for example, a respiration alarm limit violation). Additionally there are short yellow alarms, most of which are specific to arrhythmia-related patient conditions (for example, ventricular bigeminy).

INOPs

INOPs are technical alarms, they indicate that the monitor cannot measure or detect alarm conditions reliably. If an INOP interrupts monitoring and alarm detection (for example, **Leads Off**), the monitor places a question mark in place of the measurement numeric and an audible indicator tone will be sounded. INOPs without this audible indicator indicate that there may be a problem with the reliability of the data, but that monitoring is not interrupted.

Most INOPs are light blue, however there are a small number of INOPs which are always yellow or red to indicate a severity corresponding to red and yellow alarms. The following INOPs can also be configured as red or yellow INOPs to provide a severity indication:

- **ECG Leads Off**
- **NBP Cuff Overpress**
- **Cuff Not Deflated**
- **Occlusion**
- **<SpO₂ Label> No Pulse**
- **<Press Label> No Pulse**
- **Tele Disconnected**
- **Battery Empty / Replace Battery**

All monitors in a unit should have the same severity configured for these INOPs.

Alarm Delays

There is a delay between a physiological event at the measurement site and the corresponding alarm indication at the monitor. This delay has two components:

- **The general measurement delay time is the time between the occurrence of the physiological event and when this event is represented by the displayed numerical values.** This delay depends on the algorithmic processing and, for certain measurements (e.g. SpO₂), on the configured averaging time. The longer the averaging time configured, the longer the time needed until the numerical values reflect the physiological event.
- **The time between the displayed numerical values crossing an alarm limit and the alarm indication on the monitor.** This delay is the sum of the alarm delay configured for the specific measurement plus the system alarm delay. The system alarm delay is the processing time the system needs for any alarm on the monitor to be indicated after the measurement has triggered the alarm. See the performance specifications in the Specifications chapter for the system alarm delay specification.

The alarm delay configured for a specific measurement is normally a fixed time. For SpO₂ it is also possible to configure a Smart Alarm Delay that is calculated using an intelligent algorithm. See “[Smart Alarm Delay](#)” on page 208 in the SpO₂ chapter for more details.

Multiple Alarms

If more than one alarm is active, the alarm messages are shown in the alarm status area in succession. An arrow symbol next to the alarm message informs you that more than one message is active.

The monitor sounds an audible indicator for the highest priority alarm. If more than one alarm condition is active in the same measurement, the monitor announces the most severe. Your monitor may be configured to increase alarm indicator volume automatically during the time when the alarm is not acknowledged.

Visual Alarm Indicators

WARNING

- No alarms are available on an X2/X3 when connected to a host monitor (**Companion Mode** is indicated). Alarms become active again as soon as the X2/X3 is disconnected from the host monitor.
 - Alarm fields and other visual alarm indicators are disabled on an X2/X3 when connected to a host monitor. The only visual alarm indication is provided by the alarm lamps, which are controlled by the host monitor.
-

Alarm Message

An alarm message text appears in the alarm status area at the top of the screen indicating the source of the alarm. If more than one measurement is in an alarm condition, the message changes every two seconds, and has an arrow (↑) at the side. The background color of the alarm message matches the alarm priority: red for red alarms, yellow for yellow alarms, light blue for standard INOPs, red for red INOPs and yellow for yellow INOPs. The asterisk symbols (*) beside the alarm message match the alarm priority: *** for red alarms, ** for yellow alarms, * for short yellow alarms. Standard INOPs do not have a symbol, red and yellow INOPs have exclamation marks beside the alarm message: !!! for red INOPs and !! for yellow INOPs.

Depending on how your monitor is configured, it may display alarm limit violation messages:

- in text form, for example **** SpO₂ Low** or
- in numeric form, for example **** Pulse xxx>yyy** where the first number shows the maximum deviation from the alarm limit, and the second number shows the currently set limit.

Flashing Numeric

In the default configuration, the background of the alarming measurement numeric flashes in the alarm severity color. Once the alarm is acknowledged, the background stops flashing, and the numeric flashes.

In the alternative configuration, the numeric of the measurement in alarm flashes and continues to flash in the same way after the alarm is acknowledged.

Bright Alarm Limits

If the alarm was triggered by an alarm limit violation, the corresponding alarm limit on the monitor screen is shown more brightly if **Show AlarmLimits** is enabled and there is sufficient room on the screen.

Alarm Lamp

A lamp on the monitor front panel, or on the Active Display, flashes or lights. The alarm lamp is divided into two sections. The right one flashes for a patient alarm, except for short yellow alarms where the lamp will light continuously for approximately six seconds. The color is yellow or red corresponding to the highest priority patient alarm currently present. The left one lights continuously for a light blue INOP and flashes for yellow or red INOPs as follows:

INOP Lamp Color	On	Off
Yellow	1.0 seconds	1.0 seconds
Red	0.25 seconds	0.25 seconds

If only patient alarms are present, and no INOPs, the patient alarms will use both left and right sections to flash (for red and yellow alarms) or light for approximately six seconds (for short yellow alarms). If only INOPs are present, and no patient alarms, red and yellow INOPs will use both left and right sections to flash but light blue INOPs will always light continuously in the left section only.

If the screen brightness is configured to automatically adapt to ambient light conditions, the alarm lamps will also adapt their brightness accordingly.

Nurse Call Systems

If configured to do so, red, yellow and light blue alarms are indicated on any device connected to the nurse call relay.

Audible Alarm Indicators

The audible alarm indicators configured for your monitor depend on which alarm standard applies in your hospital. Audible alarm indicator patterns are repeated until you acknowledge the alarm by switching it off or pausing it, or until the alarm condition ceases (if audible alarm indication is set to non-latching).

WARNING

- Do not rely exclusively on the audible alarm system for patient monitoring. Adjustment of alarm volume to a low level or off during patient monitoring may result in patient danger. Remember that the most reliable method of patient monitoring combines close personal surveillance with correct operation of monitoring equipment.
 - No audible alarm indicators are available on an X2/X3 when connected to a host monitor (**Companion Mode** is indicated). Alarms become active again as soon as the X2/X3 is disconnected from the host monitor.
-

Alarm Tone Configuration

The audible alarm indicators of your monitor are configurable. In the monitor's Configuration Mode, you can:

- increase the alarm volume of unacknowledged alarms at regular intervals
- change the interval between alarm sounds (ISO/IEC Standard alarms only)
- change the base volume of the red and yellow alarm tones and the INOP tones
- change the alarm sound to suit the different alarm standards valid in different countries.

Traditional Audible Alarms (HP/Agilent/Philips/Carenet)

- Red alarms and red INOPs: A high pitched sound is repeated once a second.
- Two-star yellow alarms and yellow INOPs: A lower pitched sound is repeated every two seconds.
- One-star yellow alarms (short yellow alarms): The audible indicator is the same as for yellow alarms, but of shorter duration.
- Standard INOPs: an INOP tone is repeated every two seconds.

ISO/IEC Standard Audible Alarms

- Red alarms and red INOPs: A high pitched tone is repeated five times, followed by a configurable pause.
- Two-star yellow alarms and yellow INOPs: A lower pitched tone is repeated three times, followed by a configurable pause.
- One-star yellow alarms (short yellow alarms): The audible indicator is the same as for yellow alarms, but of shorter duration.
- Standard INOPs: a lower pitched tone is repeated twice, followed by a pause.

Changing the Alarm Tone Volume

- The alarm volume symbol at the top right of the monitor screen gives you an indication of the current volume.



To change the volume, select the volume symbol and then select the required volume from the pop-up selection.

- If you want to see a numerical indication of the current alarm volume on a scale from zero to 10, or change the setting, select the **Alarm Volume** SmartKey.



The volume scale pops up. The current setting is indented. To change the setting, select the required number on the scale. Any settings that are inactive ("grayed out") have been disabled in the monitor's Configuration Mode.

- When the alarm volume is set to zero (off), the alarm volume symbol reflects this.



If you switch the alarm volume off, you will not get any audible indication of alarm conditions.

There is no alarm volume indication on the screen of an X2/X3 when connected to a host monitor (**Companion Mode** is indicated).

Minimum Volume for No Central Monitoring INOP

If your monitor is connected to an Information Center, and the connection is interrupted, the INOP message **No Central Monit.** will appear within 30 seconds, accompanied by an INOP tone. To help ensure that this INOP, and any other active alarm, is not overlooked, the INOP and alarm tones may be configured to have a minimum volume. In this case, INOP and alarm tones will sound even if the monitor alarm volume is set to zero.

Minimum Volume for Severe Yellow or Red INOPs

Severe yellow or red INOPs require action to ensure the well-being of the patient. Therefore the minimum volume for the INOP tone is set to at least alarm volume 8, irrespective of the current alarm volume setting. The INOP tone will sound even if the monitor alarm volume is set to zero.

The severe INOPs for which this applies are:

Cuff Not Deflated (configurable to yellow or red)

NBP Cuff Overpress (configurable to yellow or red)

!! Insert Battery - X2/X3 (yellow)

Battery Empty / Replace Battery - (configurable to light blue, yellow or red)

Power Loss Tone



When power is lost - no power is available via the power cable or battery (where available) - a buzzer will sound, if so configured. The tone can be silenced by pressing the On/Off power switch.

Acknowledging Alarms



To acknowledge all active alarms and INOPs, select the **Acknowledge** permanent key. This switches off the audible alarm indicators and alarm lamps.

Alternatively, you can acknowledge alarms by pressing the **Acknowledge** hardkey on the Multi-Measurement Module. The hardkeys follow the behavior configured for the permanent key.

A check mark beside the alarm message indicates that the alarm has been acknowledged . If the monitor is configured to re-alarm, a dashed check mark will be shown .



If the condition that triggered the alarm is still present after the alarm has been acknowledged, the alarm message stays on the screen with a check mark symbol beside it, except for NBP alarms and alarms from other intermittent measurements. When such an alarm is acknowledged the alarm message disappears.

If the alarm condition is no longer present, all alarm indicators stop and the alarm is reset.

Switching off the alarms for the measurement in alarm, or switching off the measurement itself, also stops alarm indication.

Acknowledging Disconnect INOPs

Acknowledging an INOP that results from a disconnected transducer switches off the associated measurement. The only exception is ECG/Resp: acknowledging a disconnect INOP for ECG leads does not switch off the ECG and Resp measurements. Acknowledging a disconnect INOP at the Information Center switches off the audible INOP indicator but does not switch off the measurement.

Unplugging a Multi-Measurement Module or a plug-in module automatically switches off its measurements.

Alarm Reminder

If **Alarm Reminder** is configured on for your monitor, you will get an audible reminder of alarm conditions that remain active after you have acknowledged the alarm. This reminder may take the form of a repetition of the alarm tone for a limited time (1, 2, or 3 minutes), or an unlimited repetition of the alarm tone (this is the same as a new alarm). **Alarm Reminder** is not available for standard, light blue INOPs but for yellow and red INOPs.

In Configuration Mode, you can set the interval between acknowledging the alarm and sounding the reminder tone to one, two, or three minutes.

The alarm reminder behavior at the Information Center is different to that at the monitor. Refer to the Information Center Instructions for Use for further information.

Pausing or Switching Off Alarms

If you want to temporarily prevent alarms from sounding, for example while you are moving a patient, you can pause alarms. Depending on your monitor configuration, alarms are paused for one, two, or three minutes, or infinitely. Infinite alarm pause is equivalent to switching the alarms off.

To view the alarm pause setting chosen for your unit,

- 1 Select **Main Setup, Alarms**, then **Alarm Settings**
- 2 Check the **Alarms Off** setting.

This setting can only be changed in Configuration Mode.

There are some settings made in Configuration Mode that can affect the availability of the pause alarms functionality.

- The **Pause Alarms / Alarms Off** permanent key can be removed from the screen to avoid unintentional switching off of alarms. In this case you can only pause alarms or switch alarms off permanently in the **Alarms** menu, under **Main Setup**.
- The **Pause Alarms / Alarms Off** permanent key and the corresponding hardkey can be configured to pause or switch off red and yellow alarms, yellow alarms only, or not to function at all. If they are configured not to function, you cannot pause alarms or switch alarms off permanently at all.

When the alarms off priority is set to **Yellow Only**, the **Pause Alarms / Alarms Off** key becomes the **Pause Yellow / Yellow Al. Off** key.

To Pause or Switch Off All Alarms

To pause alarms:

- Touch and hold the **Acknowledge** key until a confirmation window appears. In the window, select the pause time to confirm that alarms be paused.

If your monitor is configured to allow infinite alarms pause, select **Yes** in the window to confirm that the alarms be switched off.

To Switch Individual Measurement Alarms On or Off

- 1 Select the measurement numeric to enter its setup menu.
- 2 Select **Alarms** to switch between on and off.



The alarms off symbol is shown beside the measurement numeric.

While Alarms are Paused or Off

When red alarms are paused or off:

- The red Alarms Paused lamp on the monitor front panel is lit.
In the alarm field, the monitor displays the message **Al. Paused x:yy** or **Alarms Off**, together with the alarms paused symbol **or** the alarms off symbol.

When yellow alarms are paused or off:

- The yellow Alarms Paused lamp on the monitor front panel is lit.
In the alarm field, the monitor displays the message **YellowPaused x:yy** or **Yellow Alarms Off**, together with the alarms paused symbol **or** the alarms off symbol.

For red and yellow alarms:



Alarms Paused



Alarms Off

- No alarms are sounded and no alarm messages are shown.
- INOP messages are shown but no INOP tones are sounded.

The only exceptions are the INOPs **Cuff Not Deflated**, **NBP Cuff Overpress** and INOPs relating to empty, missing and malfunctioning batteries.

These INOPs switch the alarms on, and the INOP tones are sounded, even if alarms are paused or off. You need to remove the INOP condition first before you can switch the alarm tones off again.

- The nurse call relay is not active.

If a disconnect INOP is present and alarms are paused or switched off, the measurement in question may be switched off, depending on monitor configuration.

Restarting Paused Alarms

To manually switch on alarm indication again after a pause, select the permanent key **Pause Alarms** (or **Alarms Off**) again.

Alarm indication starts again automatically after the pause period expires. If the monitor is configured to stay paused infinitely, you must select **Alarms Off** again to restart alarm indication.

Resetting Arrhythmia Alarm Timeouts

To reset the timeout period, either

- select the **Alarms Off** or **Pause Alarms** permanent key and then reselect it, or
- select **Reset Alarming** in the **Review Alarms** window or the **Alarm Messages** window.

Extending the Alarm Pause Time

If your monitor has extended alarm pause enabled, you can extend the alarm pause time. Use this to prevent alarms being indicated, for example, while you are washing a patient or carrying out a procedure. Only extend the alarm pause time when you are sure that clinical personnel are available to monitor the patient's condition closely.

To extend the alarm pause time to five or 10 minutes,

- Select one of the alarm fields. This calls up the **Alarm Messages** window.
- Select either the pop-up key **PauseAl. 5 min** or the pop-up key **PauseAl. 10 min**. Each time you select one of these pop-up keys, the Alarm Pause Time is reset to five (or 10) minutes.

Alarm Settings for Unattended Monitoring

When monitoring patients that are not continuously attended, use appropriate alarm settings to optimize monitoring:

- Always leave alarms switched on when the patient is unattended.
- Recommended configuration: Use one of the temporary settings for the **Alarms Off** setting, not **Infinite**, and make sure that the **AlarmOffReminder** and the **Alarm Reminder** are switched on (these settings are made in Configuration mode).
- Set alarm limits so that alarms will be triggered for those changes in the patient condition that you want to be advised of. Setting limits to very high or low values can render the alarm system useless.
- Use available notification routes, such as a nurse call system or the connection to an Information Center, or at least select an appropriate alarm volume to ensure that alarms are recognized.

Alarm Limits

The alarm limits you set determine the conditions that trigger yellow and red limit alarms. For some measurements (for example, BIS and SpO₂), where the value ranges from 100 to 0, setting the high alarm limit to 100 switches the high alarm off, or setting the low alarm limit to 0 switches it off. In these cases, the alarms off symbol is not displayed.

WARNING

Be aware that the monitors in your care area may each have different alarm settings, to suit different patients. Always check that the alarm settings are appropriate for your patient before you start monitoring. When changing alarm limits, use clinical judgment to assess appropriate limits for your patient and observe hospital policy.

Viewing Individual Alarm Limits

You can usually see the alarm limits set for each measurement next to the measurement numeric on the main screen.



If your monitor is not configured to show the alarm limits next to the numeric, or if the numeric is so small that the limits cannot be displayed, you can see them in the appropriate measurement setup menu. Select the measurement numeric to enter the menu and check the limits.

Viewing All Alarm Limits

(Availability is dependent on the options purchased.)

The **Alarm Limits** overview window lists the currently set alarm limits for all measurements. If an Apnea alarm delay time is set, this is also shown. The alarms off symbol is shown beside the measurement label of any measurement whose alarm switched off.



To open the **Alarm Limits** window, either select any alarm field to open the **Alarm Messages** window, then select the **Alarm Limits** pop-up key, or select the **Alarm Limits** SmartKey, if configured.

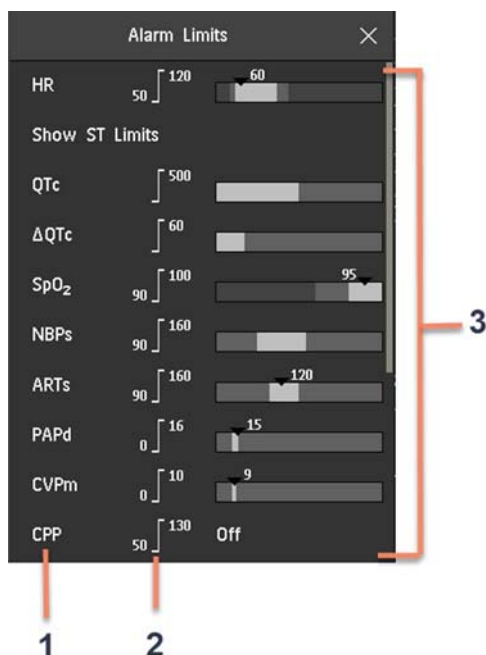

- 1 Measurement labels, with alarms off symbol where appropriate
 - 2 Current alarm limits
 - 3 Graphic view of current yellow and red alarm limits and currently monitored measurement value.
- Off** indicates the measurement is switched off.

- Select **Show ST Limits** to expand the list of ST leads and view the currently set alarm limits. Selecting **Hide ST Limits** hides the list again.

You can use the pop-up keys that open with the **Alarm Limits** window to perform common tasks:

- **All Al. On/All Al. Off**
- **All Lim. Narrow/All Lim. Wide** to set narrow or wide alarm AutoLimits for all measurements.
- **Print Limits/Record Limits** to print a list of all current alarm limit settings on a connected printer or recorder.

These pop-up keys are not available in the window for changing individual alarm limits which you access by selecting the measurement label in the **Alarm Limits** window.

Changing Alarm Limits

Set limits so that alarms will be triggered for those changes in the patient condition that you want to be advised of. Setting limits to very high or low values can render the alarm system useless.

To change individual measurement alarm limits using the measurement's Setup Menu,

- 1 In the measurement's setup menu, select the alarm limit you want to change. This calls up a list of available values for the alarm limit.
- 2 Select a value from the list to adjust the alarm limit.

Alternatively, you can use the keys in the measurement alarm limits window, which you access by selecting the measurement label in the Alarm Limits window.

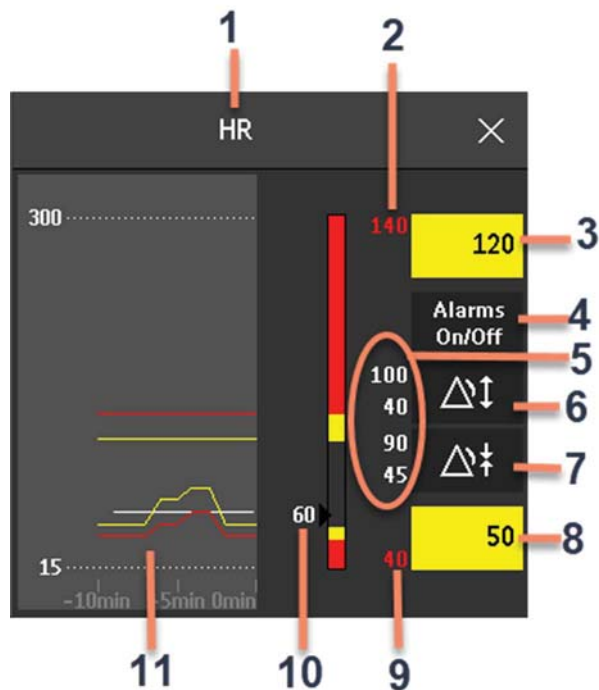

1	Parameter label
2	High red alarm limit (view only)
3	High yellow alarm limit field. Select to open a pop-up list of high alarm limits
4	Alarms On/Off key - select to switch between alarms on or off
5	Preview Alarm AutoLimits for a measurement before applying
6	Select to apply wide AutoLimits
7	Select to apply narrow AutoLimits
8	Low yellow alarm field. Select to open a pop-up list of low alarm limits
9	Low red alarm (view only)
10	Graphic view of alarm limits with currently measured value
11	15-min trend, showing alarm limits and monitored measurement values

To change alarm limits,

- 1 Enter the **Alarm Limits** window.
- 2 To set the high alarm limit, select the high yellow alarm field to open a pop-up list of high alarm limits. Select a limit from the list. Repeat to set the low yellow alarm field.

If you set the yellow alarm limit outside the red alarm limit, the monitor will automatically adapt the red alarm limit.

When an ST measurement is in the alarm limits window there are also two pop-up keys available labeled **All ST Narrow/All ST Wide**. With these keys you can set Auto Limits for all ST Leads.

Alarm Limits can also be changed at the Patient Information Center iX.

About Automatic Alarm Limits

The monitor automatically calculates alarm limits suited to your individual patient, using the Automatic Alarm Limits function (AutoLimits). The monitor calculates safe AutoLimits for the patient based on the measured values from the last 12 seconds.

The wide and narrow limits have a fixed relationship to the measured value within the non-pathological range. Outside of this range, no auto limits are calculated. To set values outside of the non-pathological range, limits must be changed manually, based on the clinician's judgment about the specific patient.

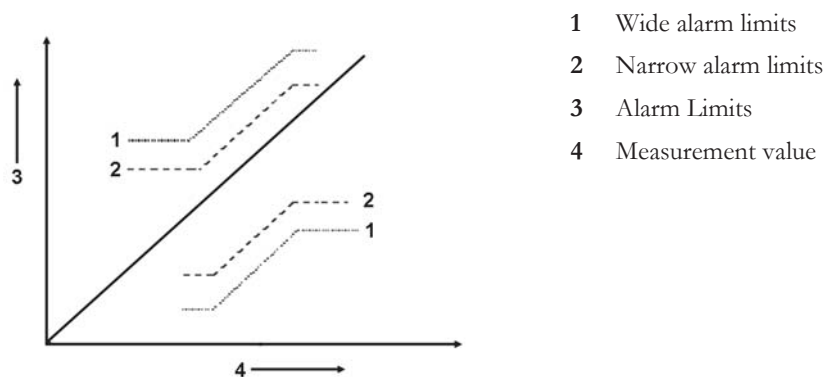

Using narrow alarm limits sets limits close to the currently measured values, for situations where it is critical for you to be informed about small changes in your patient's vital signs.

Using wide alarm limits sets limits further away from the currently measured values, for situations where small changes are not so critical.

Use the keys in the measurement alarm limits window to apply AutoLimits for individual measurements.



Narrow limits



Wide limits

These keys are not available if AutoLimits have been disabled for the measurement in the monitor's Configuration Mode.

AutoLimits are not available for all measurements. The list of measurements for which AutoLimits can be used is defined in the monitor's Configuration mode.

Use the measurement alarm limits window to check AutoLimits before you apply them to ensure that they are appropriate for your individual patient and their clinical condition. Once applied, AutoLimits are shown on the monitor screen just like manually-set alarm limits. If the AutoLimits are not appropriate for your patient, you must set alarm limits manually. The limits remain unchanged until you set them again or change them manually.

Documenting Alarm Limits

The alarm limits pop-up keys appear with the **Alarm Limits** and measurement alarm limits windows.

- Select the **Print Limits** pop-up key to print an overview of all alarm limits on a connected printer.
- Select the **Record Limits** pop-up key to send a recording of the alarm limits to a recorder.

Reviewing Alarms

You can see which alarms and INOPs are currently active in the respective alarms and INOPs fields at the top of the screen.

To see the currently active alarms and INOPs listed in one place, select any of the alarm status areas on the monitor screen. The **Alarm Messages** window pops up.

All alarms are erased from the **Alarm Messages** window when you discharge a patient, or if you change to Demonstration Mode.

Alarm Messages Window

The **Alarm Messages** window shows all the currently active alarms and INOPs sorted by priority, beginning at the top with the most recent. INOPs are shown on the left hand side and patient alarms are shown on the right hand side. Any active red alarms are shown first, followed by yellow alarms. Acknowledged alarms or INOPs are shown with the check mark symbol.

The **Alarm Messages** window pop-up keys appear when the window is opened. If alarm pause extension is disabled, the pause pop-up keys are inactive ("grayed-out"). Selecting the **Review Alarms** pop-up key opens the **Review Alarms** window.

If you do not immediately understand an INOP or alarm message, refer to its help text.

- In the **Alarm Messages** window, select the message. This calls up a help window with an explanation of the message and, where appropriate, a suggested solution for the problem.
- If the alarm or INOP was generated in a device other than the monitor (for instance, in a Multi-Measurement Module or Module Rack), this source is specified at the end of the help text.

Review Alarms Window

(Availability is dependent on the options purchased.)

The **Review Alarms** window contains a list of the most recent alarms and INOPs with date and time information.

If configured to do so, each alarm is shown with the alarm limit active when the alarm was triggered and the maximum value measured beyond this limit. The **Review Alarms** window also shows when the monitor was switched on (after being switched off for longer than 1 minute) and any actions related to switching device alarms on and off, entering or leaving Standby mode, silencing alarms or changing the ECG source.

When you select an item from the list, you can get additional information about that item. If you select a high or low limit alarm in the list, the **Graphical Trends** window will open to provide further data. If you select an alarm resulting from an event alarm notification, the **Event Episode** window for that event will open. If you select an alert other than a high or low alarm, a help text window opens with more information. This is the same as the help text window that opens in the **Alarm Messages** window. Some items in the list are simply log items not related to a patient alert as such (for example, **Alarms On** or **Alarms Off**). You cannot see any further information if you select one of these items. When you close these windows you will return to the **Review Alarms** window.

The information in the **Review Alarms** window is deleted when a patient is discharged, and when you leave Demonstration Mode.

The **Review Alarms** window pop-up keys appear when the window is opened. If alarm pause extension is disabled, the pause pop-up keys are inactive. Selecting the **Active Alarms** pop-up key opens the **Alarm Messages** window.

Alarm Advisor

Alarm advisor provides feedback on recurring and continuous alarm limit violations, for a specific measurement over a period of time. The information provided supports you in adapting alarm limits more specifically for individual patients.

Which Measurements Can Use Alarm Advisor?

The following alarms can have alarm advisor set up:

- HR (low and high limit alarm, yellow and short yellow)
- PVCs/minute (high limit alarm)
- SpO₂ (low and high limit alarm)
- Pressure - ART, ABP, Ao, P (low and high limit alarm)
- RR (low and high limit alarm)
- awRR (low and high limit alarm)

You can switch alarm advisor on and off for each individual alarm (for example, for an SpO₂ low alarm, a HR low alarm, and so on).

How Does Alarm Advisor Work?

A period of time is selected for the alarm behavior to be observed. This can vary from 30 minutes to 12 hours.

Then two criteria are selected for triggering alarm advisor:

- 1 The number of times an alarm was acknowledged in the set time period.
This can highlight situations where a measurement value is close to the limit, some of the time above and some of the time below. Changing the limit just a little would avoid these repeated alarms.
- 2 The percentage of the time period that an alarm limit was violated.
This can highlight alarm limit violations that are present over a long time. If the limit is not appropriate, changing it will avoid these alarms and the repeated alarm reminders.

An example of a resulting setup would be: Observing a **60 minute** period, alarm advisor will be triggered for alarms that are **acknowledged at least 5 times** or are **present for more than 50% of the time**.

The settings described above are made in Configuration Mode.

Getting Notified About an Alarm Advisor

When the alarm advisor criteria are met for a particular alarm limit, an alarm advisor is triggered. The alarm advisor window appears automatically the next time you acknowledge the alarm (depending on your configuration).

In addition, a notification symbol appears in the status area at the bottom right of the screen (also called the system tray):



If the alarm advisor window is not displayed:

- 1 Select the notification symbol.
The **Notifications** window opens.
- 2 Select the alarm advisor notification from the list.
The alarm advisor window opens.

If you have closed the alarm advisor window without changing an alarm limit, you can open it again using the notification symbol, as described above. If, in the meantime, the criteria are no longer met, the notification will be canceled and you can no longer view the window.

Alarm Advisor Window

Here is an example of an alarm advisor window:



- SpO2I Low has been acknowledged at least 5 times in the last 60min.** This first text line gives you information about the criterion that has been met. In this case, a low SpO2I alarm was acknowledged at least 5 times in the set time period.
- Check patient. If acceptable, consider adjusting the low limit.** This second text line is a recommendation for a change that may avoid such situations in future. Here, this is an adjustment of the low alarm limit. Your monitor may be configured not to show a recommendation, or to show a different text than the standard one.

Under the text there are three elements shown:

- On the left is a graphical trend showing the alarm limit violations over one and a half times the set time period.
The current alarm limit, here 95, is shown as a horizontal line. The area below the line, filled in yellow, represents violations of the limit. You can see at a glance what proportion of the time the limit was violated.
- Next to the graphical trend, there are up and down arrow keys that let you try out a new limit.
In the case above, you would use the down arrow key to move the limit to, for example, 80. The line on the graphical trend then also moves to show what effect this new limit has on the alarm violations. In the case of the HR alarms, the extreme limit shown in red (here bradycardia), will also move correspondingly. If you want to keep the new limit, use the **Apply** key to set that limit. When you apply a new limit, the window closes.

CAUTION

Be aware that setting a new limit in the alarm advisor window is the same as changing an alarm limit in a setup menu. The limit you set will stay active indefinitely, until the setting is changed again.

Changing alarm limits always requires your clinical judgment of the patient's condition, and observation of hospital policy.

- On the right, the currently measured value and the current alarm limits are shown. Additionally, a second numeric provides additional clinical context. For HR alarms, the second numeric is the pulse numeric. This allows you to see, for example, differences between the pulse rate and the HR that can indicate miscounting or double-counting of the HR.

The pop-up keys at the bottom of the screen provide two functions:

- **Viewing the graphical trend** - use the right and left arrow keys to move along the time axis and view alarm behavior at other times. Use the key between the arrow keys, here **Trend 60 min**, to select a longer or shorter graphical trend for viewing.
- **Clearing collected data and starting a new collection time period** - use the **Reset Counter** key to delete the collected alarm behavior data and start again. For example, after a procedure or moving a patient has caused atypical values to be measured, that are not a suitable basis for evaluating alarm behavior.

Latching Alarms

The alarm latching setting for your monitor defines how the alarm indicators behave when you do not acknowledge them. When alarms are set to non-latching, their indicators end when the alarm condition ends. Switching alarm latching on means that visual and/or audible alarm indications are still displayed or announced by the monitor after the alarm condition ends. The indication lasts until you acknowledge the alarm.

NOTE

If a latching alarm is not acknowledged and the same alarm condition occurs again,

- this alarm is not listed in the alarm review or the audit log of PIC iX as a new alarm.
- this alarm cannot be paged.
- no alarm recording is available for this alarm.

Note that when your monitor is configured to visual latching and audible non-latching, the reoccurrence of the alarm condition generates a new audible alarm and the corresponding alarm lamp flashes, but the alarm banner displays the latched alarm. If your alarm text is configured to **Enhanced**, the alarm text shows the maximum deviation from the alarm limit and is updated with the reoccurred alarm.

Viewing the Alarm Latching Settings

To see the alarm latching setting for your monitor:

- 1 In the monitor's **Main Setup** menu, select **Alarms**.
- 2 Select **Alarm Settings**, and see the **Visual Latching** and **Audible Latching** settings.

This setting can only be changed in Configuration Mode. You should be aware of the settings chosen for your unit. There are three possible choices each for visual and audible latching, red only, red and yellow, and off. These choices can be combined to give the following settings:

Visual Latching	Audible Latching
Red&Yellow	Red&Yellow
Red&Yellow	Red Only
Red&Yellow	Off
Red Only	Red Only
Red Only	Off
Off	Off

Alarm Latching Behavior

Red & Yellow Measurement Alarms		Non-latching alarms	Visual and audible latching	Visual latching, audible non-latching
Alarm has not been acknowledged.	Alarm condition still present.	Alarm tone on. Alarm lamp on. Alarm message. Flashing numerics.	Alarm tone on. Alarm lamp on. Alarm message. Flashing numerics.	Alarm tone on. Alarm lamp on. Alarm message. Flashing numerics.
	Alarm condition no longer present.	All audible and visual alarm indicators automatically stop.	Alarm tone on. Alarm lamp on. Alarm message. Flashing numerics.	Alarm message. Flashing numerics. Audible alarm indicators automatically stop.
Alarm has been acknowledged.	Alarm condition still present.	Alarm tone off. Alarm lamp off. Alarm message. Flashing numerics. Audible alarm reminder (if configured).	Alarm tone off. Alarm lamp off. Alarm message. Flashing numerics. Audible alarm reminder (if configured).	Alarm tone off. Alarm lamp off. Alarm message. Flashing numerics. Audible alarm reminder (if configured).
	Alarm condition no longer present.	Audible and visual alarm indicators automatically stop.	Audible and visual alarm indicators automatically stop.	Audible and visual alarm indicators automatically stop.

All INOPs are non-latching. See “[Yellow Arrhythmia Alarms](#)” on page 175 for information on one-star yellow alarms latching behavior.

Testing Alarms

When you switch the monitor on, a selftest is started. You must check that the alarms lamps light, one after the other, and that you hear a single tone. This indicates that the visible and audible alarm indicators are functioning correctly. For further testing of individual measurement alarms, perform the measurement on yourself (for example SpO₂ or CO₂) or use a simulator. Adjust alarm limits and check that appropriate alarm behavior is observed.

Alarm Behavior at Power On

If the monitor is switched off for longer than one minute and then switched on again (or after a loss of power lasting longer than one minute, or when a patient is discharged), the monitor can be configured to:

- restore the alarm settings from the monitor's configured default Profile,
- restore the most recently used alarm settings, or
- switch the alarms off.

After any of these situations, you should check that the alarm settings are appropriate for your patient and monitoring situation, and if necessary, select the correct Profile and patient category.

If power is lost for less than one minute, the alarm on/off condition prior to the power loss is restored.

Alarm Recordings

You can set up your monitor so that it automatically triggers alarm recordings locally or at the Information Center, or if configured, to a printer as a realtime report.

- 1 Press the **Main Setup** SmartKey.
- 2 Select **Alarms** from the **Main Setup** menu.
- 3 Select **Alarm Recording** from the **Alarms** menu to open the **Alarm Recordings** menu.
- 4 Select a measurement from those listed for which you want to change the alarm condition that triggers an alarm recording. This opens a pop-up list.
- 5 For the desired measurement(s), choose the alarm condition to trigger an alarm recording:
 - Red Only:** an alarm recording will automatically be triggered when the measurement enters a red alarm condition.
 - Red&Yellow:** both yellow and red alarms will trigger an alarm recording.
 - Off:** disables automatic alarm recording.

Refer to the Recording chapter for details of how to set up a recording.

Patient Alarms and INOPs

This chapter lists patient alarms alphabetically, and technical alarms (INOPs) arranged by the source of the INOP and then alphabetically, irrespective of their priority. All alarms and INOPs are listed here; the ones which can appear on your monitor will depend on the model and the individual options.

Refer to your IntelliBridge Device Driver Instructions for Use for patient alarms and INOPs from connected external devices.

Refer to your G1/G5 Instructions for Use for patient alarms and INOPs from the G1/G5 gas analyzers.

Refer to your IntelliVue TcG10 Instructions for Use for patient alarms and INOPs from the TcG10 (865298).

Patient Alarm Messages

Alarm Message	From	Condition	Indication
* AFIB	ECG/Arrhythmia	Atrial fibrillation waveform detected	yellow alarm lamp, short yellow alarm tone
** AGT Mix MAC > 3	GM	An agent mixture has been detected and the sum of the 2 agent MAC components + MAC (N ₂ O) is ≥ 3 MAC (uncorrected)	yellow alarm lamp, alarm tone.
*** Apnea	CO ₂ , Respiration, GM	Respiration has stopped for longer than the preset apnea time.	numeric flashes, red alarm lamp, alarm tone
*** Apnea x:yy	CO ₂ , Respiration, GM	This is the alternative alarm message for *** Apnea , when the alarm text setting is Enhanced . Respiration has stopped for longer than the preset apnea time. "x:yy" denotes the Apnea duration in minutes and seconds.	numeric flashes, red alarm lamp, alarm tone
*** Asystole	ECG	No QRS detected for a period > the asystole alarm threshold	numeric flashes, red alarm lamp, alarm tone
** awRR High	CO ₂ , Respiration, AGM, GM	The airway respiration rate has exceeded the high alarm limit.	numeric flashes and high limit is highlighted, yellow alarm lamp, alarm tone
** awRR Low	CO ₂ , Respiration, AGM, GM	The airway respiration rate has dropped below the low alarm limit.	numeric flashes and low limit is highlighted, yellow alarm lamp, alarm tone
** <BIS Label> High	BIS	The Bispectral Index value has exceeded the high alarm limit.	numeric flashes and high limit is highlighted, yellow alarm lamp, alarm tone
** <BIS Label> Low	BIS	The Bispectral Index value has dropped below the low alarm limit.	numeric flashes and low limit is highlighted, yellow alarm lamp, alarm tone

3 Patient Alarms and INOPs

Alarm Message	From	Condition	Indication
*** Brady (Pulse)	SpO ₂ , Pressure, cmResp	Pulse rate < the extreme brady alarm limit.	numeric flashes and alarm limit is highlighted, red alarm lamp, alarm tone
*** Brady/P xxx<yyy	SpO ₂ , Pressure, cmResp	This is the alternative alarm message for *** Brady (Pulse) , when the alarm text setting is Enhanced . Pulse rate < the extreme bradycardia alarm limit. xxx denotes the lowest measured value; yyy is the extreme bradycardia limit.	numeric flashes and alarm limit is highlighted, red alarm lamp, alarm tone
*** Bradypnea	cmResp	The respiration rate has dropped below the bradypnea limit.	numeric flashes and alarm limit is highlighted, red alarm lamp, alarm tone
** CCI High	CCI	CC Index is above the high alarm limit.	numeric flashes and high alarm limit is highlighted, yellow alarm lamp, alarm tone
** CCI Low	CCI	CC Index is below the low alarm limit.	numeric flashes and low alarm limit is highlighted, yellow alarm lamp, alarm tone
** CCO High	CCO	Continuous Cardiac Output is above the high alarm limit.	numeric flashes and high alarm limit is highlighted, yellow alarm lamp, alarm tone
** CCO Low	CCO	Continuous Cardiac Output is below the low alarm limit.	numeric flashes and low alarm limit is highlighted, yellow alarm lamp, alarm tone
** cmRR High	cmResp	The respiration rate has exceeded the high alarm limit.	numeric flashes and high alarm limit is highlighted, yellow alarm lamp, alarm tone
** cmRR Low	cmResp	The respiration rate has dropped below the low alarm limit.	numeric flashes and low alarm limit is highlighted, yellow alarm lamp, alarm tone
** CPP High	CPP	The CPP value has exceeded the high alarm limit.	numeric flashes and high limit is highlighted, yellow alarm lamp, alarm tone
** CPP Low	CPP	The CPP value has fallen below the low alarm limit.	numeric flashes and low limit is highlighted, yellow alarm lamp, alarm tone
*** Desat	SpO ₂	The SpO ₂ value has fallen below the desaturation alarm limit.	numeric flashes, red alarm lamp, alarm tone
*** Desat xx < yy	SpO ₂	This is the alternative alarm message for *** Desat , when the alarm text setting is Enhanced . The SpO ₂ value has fallen below the desaturation alarm limit. xx denotes the lowest measured value, and yy is the desaturation limit.	numeric flashes, red alarm lamp, alarm tone
** EC10 Alarm *** EC10 Alarm at Information Center	EC10 IntelliBridge	A yellow (**) or red (***) patient alarm is present on the IntelliBridge module. Check the monitor display for more detailed alarm information.	(on monitor) yellow or red alarm lamp; the alarm text is defined by the IntelliBridge device driver
* End AFIB	ECG/Arrhythmia	Atrial fibrillation no longer detected for the configured Afib end delay time	yellow alarm lamp, short yellow alarm tone

Alarm Message	From	Condition	Indication
* End Irregular HR	ECG/Arrhythmia	Irregular HR no longer detected for the configured irregular HR end delay time.	yellow alarm lamp, short yellow alarm tone
** et<Agent Label> High	GM	The end tidal agent high alarm limit has been exceeded.	numeric flashes and high limit is highlighted, yellow alarm lamp, alarm tone
** et<Agent Label> Low	GM	The end tidal agent value has fallen below the low alarm limit	numeric flashes and low limit is highlighted, yellow alarm lamp, alarm tone
** etCO ₂ High	CO ₂ , AGM, GM	The end tidal CO ₂ high alarm limit has been exceeded.	numeric flashes and high limit is highlighted, yellow alarm lamp, alarm tone
** etCO ₂ Low	CO ₂ , AGM, GM	The end tidal CO ₂ value has fallen below the low alarm limit.	numeric flashes and low limit is highlighted, yellow alarm lamp, alarm tone
** etO ₂ High	O ₂ , AGM	The end tidal O ₂ high alarm limit has been exceeded.	numeric flashes and high limit is highlighted, yellow alarm lamp, alarm tone
** etO ₂ Low	O ₂ , AGM	The end tidal O ₂ value has fallen below the low alarm limit.	numeric flashes, and low limit is highlighted, yellow alarm lamp, alarm tone
* Event ** Event *** Event at Information Center	Event surveillance	An event has occurred and the event notification is configured to alarm. Check on the monitor for more details on event group.	(on monitor) event group name flashes, yellow or red alarm lamp and alarm tone
* Event:<Event Group> ** Event:<Event Group> *** Event:<Event Group>	Event surveillance	An event has occurred and the event notification is configured to alarm.	event group name flashes, yellow or red alarm lamp and alarm tone
*** Extreme Brady	ECG	Heart rate < the extreme brady alarm limit.	numeric flashes and alarm limit is highlighted, red alarm lamp, alarm tone
*** Extreme Tachy	ECG	Heart rate > the extreme tachy alarm limit.	numeric flashes and alarm limit is highlighted, red alarm lamp, alarm tone
* HR High ** HR High	ECG	Heart rate > the high HR alarm limit	numeric flashes and high limit is highlighted, yellow alarm lamp, alarm tone. If configured to short yellow, the sound switches off after 5 seconds if Arrhythmia is switched on.
* HR Low ** HR Low	ECG	Heart rate < the low HR alarm limit	numeric flashes and low limit is highlighted, yellow alarm lamp, alarm tone. If configured to short yellow, the sound switches off after 5 seconds if Arrhythmia is switched on.
** imCO ₂ High	GM	The inspired minimum CO ₂ high alarm limit has been exceeded	numeric flashes and high limit is highlighted, yellow alarm lamp, alarm tone.
** in<Agent Label> High	GM	The inspired agent high alarm limit has been exceeded	numeric flashes, high limit is highlighted, yellow alarm lamp, alarm tone

3 Patient Alarms and INOPs

Alarm Message	From	Condition	Indication
** in<Agent Label> Low	GM	The inspired agent value has fallen below the AGT low alarm limit	numeric flashes, low limit is highlighted, yellow alarm lamp, alarm tone
** inN ₂ O High	GM	The inspired N ₂ O high alarm limit has been exceeded.	numeric flashes, high limit is highlighted, yellow alarm lamp, alarm tone.
** inO ₂ High	GM	The inspired O ₂ high alarm limit has been exceeded.	numeric flashes, high limit is highlighted, yellow alarm lamp, alarm tone.
** inO ₂ Low	GM	The inspired O ₂ value has fallen below the low alarm limit	numeric flashes, low limit is highlighted, yellow alarm lamp, alarm tone
*** inO ₂ Low Oxygen	GM	The inspired O ₂ value has fallen below 18 vol%.	numeric flashes, low limit is highlighted, red alarm lamp, alarm tone
** IPI Low	CO ₂	The IPI value has fallen below the low alarm limit.	numeric flashes, and low limit is highlighted, yellow alarm lamp, alarm tone
* Irregular HR	ECG/Arrhythmia	Consistently irregular rhythm (irregular R-R intervals).	numeric flashes, yellow alarm lamp, short yellow audible alarm
** <iTemp Label> High	iTemp	The temperature value has exceeded the high alarm limit.	numeric flashes and high limit is high-lighted, yellow alarm lamp, alarm tone
** <iTemp Label> Low	iTemp	The temperature value has dropped below the low alarm limit.	numeric flashes and low limit is high-lighted, yellow alarm lamp, alarm tone
* Missed Beat	ECG/Arrhythmia	No beat detected for > 1.75*(the averaged R-R interval), or no beat detected for > one second if HR > 120 (For non-paced patients only).	numeric flashes, yellow alarm lamp, short yellow audible alarm
* More Alarms ** More Alarms *** More Alarms	other assigned devices	There is more than one physiological alarm of the corresponding severity active on the devices that monitor this patient. For details, check the information displayed at the Information Center.	yellow or red alarm lamp and alarm tone
* Multiform PVCs	ECG/Arrhythmia	Two different shaped Vs detected, each occurring at least twice within the last 300 beats and at least once within the last 60 beats.	numeric flashes, yellow alarm lamp, short yellow audible alarm
** NBP High	NBP	The measured NBP value is above the high alarm limit. s, d, or m after the label indicates whether the systolic, diastolic or mean pressure has crossed the limit.	numeric flashes and high limit is highlighted, yellow alarm lamp, alarm tone
** NBP Low	NBP	The measured NBP value is below the low alarm limit. s, d, or m after the label indicates whether the systolic, diastolic or mean pressure has crossed the limit.	numeric flashes and low limit is highlighted, yellow alarm lamp, alarm tone
* Non-Sustain VT	ECG/Arrhythmia	A run of PVCs < the V-Tach run limit and ventricular heart rate > the V-Tach HR limit	numeric flashes, yellow alarm lamp, short yellow audible alarm

Alarm Message	From	Condition	Indication
* OtherMon Alarm ** OtherMon Alarm *** OtherMon Alarm	another assigned monitor	Another monitor used for the patient is in an alarm condition. Check the detailed alarm information at the Information Center.	yellow or red alarm lamp and alarm tone
* Pacer Not Capt	ECG/Arrhythmia (paced patients only)	No beat detected for > 1.75*(the averaged R-R interval) with detected pace pulse(s). (For paced patients only).	numeric flashes, yellow alarm lamp, short yellow audible alarm
* Pacer Not Pacing	ECG/Arrhythmia (paced patients only)	No beat and pace pulse detected for > 1.75*(the averaged R-R interval). (For paced patients only).	numeric flashes, yellow alarm lamp, short yellow audible alarm
* Pair PVCs	ECG/Arrhythmia	Two ventricular beats between two non-ventricular beats.	numeric flashes, yellow alarm lamp, short yellow audible alarm
* Pause	ECG/Arrhythmia	No beat detected for a period > the pause threshold.	numeric flashes, yellow alarm lamp, short yellow audible alarm
*** <Press Label> Disconnect	Pressure	The pressure is non-pulsatile and the mean pressure is continuously less than 10 mmHg (1.3 kPa). This alarm occurs only with arterial pressures (P, ABP, ART, Ao, BAP, FAP, LFP, RFP, PAP, UAP, P1, P2, P3, P4, Pa1, Pa2, Pa3, Pa4).	numeric flashes, red alarm lamp, alarm tone
*** <Press Label> High	Pressure	The measured pressure value is above the extreme high alarm limit. s, d, or m after the label indicates whether the systolic, diastolic or mean pressure has crossed the limit.	numeric flashes, high limit is highlighted, red alarm lamp, alarm tone
** <Press Label> High	Pressure	The measured pressure value is above the high alarm limit. s, d, or m after the label indicates whether the systolic, diastolic or mean pressure has crossed the limit.	numeric flashes, high limit is highlighted, yellow alarm lamp, alarm tone
*** <Press Label> Low	Pressure	The measured pressure value is below the extreme low alarm limit. s, d, or m after the label indicates whether the systolic, diastolic or mean pressure has crossed the limit.	numeric flashes and low limit is highlighted, red alarm lamp, alarm tone
** <Press Label> Low	Pressure	The measured pressure value is below the low alarm limit. s, d, or m after the label indicates whether the systolic, diastolic or mean pressure has crossed the limit.	numeric flashes and low limit is highlighted, yellow alarm lamp, alarm tone
** <pTemp Label> High	pTemp	The temperature value has exceeded the high alarm limit.	numeric flashes and high limit is high-lighted, yellow alarm lamp, alarm tone
** <pTemp Label> Low	pTemp	The temperature value has dropped below the low alarm limit.	numeric flashes and low limit is high-lighted, yellow alarm lamp, alarm tone
** Pulse High	Pressure, SpO ₂ , cmResp	The pulse rate has exceeded the high alarm limit.	numeric flashes and high limit is highlighted, yellow alarm lamp, alarm tone
** Pulse Low	Pressure, SpO ₂ , cmResp	The pulse rate has dropped below the low alarm limit.	numeric flashes and low limit is highlighted, yellow alarm lamp, alarm tone

3 Patient Alarms and INOPs

Alarm Message	From	Condition	Indication
* PVCs/min High	ECG/Arrhythmia	PVCs detected within a minute > the alarm limit	numeric flashes, yellow alarm lamp, short yellow audible alarm
** QTc High	ECG/QT	QTc value has exceeded the QTc high limit for more than 5 minutes	numeric flashes, yellow alarm lamp, alarm tone
** ΔQTc High	ECG/QT	ΔQTc value has exceeded the ΔQTc high limit for more than 5 minutes	numeric flashes, yellow alarm lamp, alarm tone
* R-on-T PVCs	ECG/Arrhythmia	For HR < 100, a PVC with R-R interval < 1/3 the average interval followed by a compensatory pause of 1.25*(the average R-R interval), or two such Vs without compensatory pause occurring within 5 minutes of each other. (When HR > 100, 1/3 R-R interval is too short for beat detection)	numeric flashes, yellow alarm lamp, short yellow audible alarm
** RR High	Respiration	The respiration rate has exceeded the high alarm limit.	numeric flashes and high limit is highlighted, yellow alarm lamp, alarm tone
** RR Low	Respiration	The respiration rate has dropped below the low alarm limit.	numeric flashes and low limit is highlighted, yellow alarm lamp, alarm tone
* Run PVCs High	ECG/Arrhythmia	A run of > 2 PVCs.	numeric flashes, yellow alarm lamp, short yellow audible alarm
** <SO ₂ Label> High	SvO ₂ /SO ₂	The the measured intravascular oxygen saturation has exceeded the high limit.	numeric flashes and high alarm limit is highlighted, yellow alarm lamp, alarm tone
** <SO ₂ Label> Low	SvO ₂ /SO ₂	The measured intravascular oxygen saturation has fallen below the low limit.	numeric flashes and low alarm limit is highlighted, yellow alarm lamp, alarm tone
** <SpO ₂ Label> High	SpO ₂	The arterial oxygen saturation has exceeded the high alarm limit.	numeric flashes and high limit is highlighted, yellow alarm lamp, alarm tone
** <SpO ₂ Label> Low	SpO ₂	The arterial oxygen saturation has fallen below the low alarm limit.	numeric flashes and low limit is highlighted, yellow alarm lamp, alarm tone
** ST Multi <n>,<n>	ECG/ST	Two contiguous ST leads <n> and <n> have exceeded elevation or depression limits for more than 60 seconds. The limit violations for both leads must be with respect to same limit; either both above the high limit or both below the low limit.	numeric flashes, yellow alarm lamp, alarm tone
** ST Multi at Information Center	ECG/ST	The ST depression or elevation is outside of the limit in two or more leads. Check on the monitor	(on monitor) numeric flashes, yellow alarm lamp, alarm tone
** STE <n>,<n>	ECG/ST	Two contiguous leads <n> and <n> are above their respective STE limits	numeric flashes, yellow alarm lamp, alarm tone
** ST-<n> High	ECG/ST	The ST elevation in lead <n> is higher than the limit. Lead is not contiguous with any other lead.	numeric flashes and high alarm limit is highlighted, yellow alarm lamp, alarm tone
** ST-<n> Low	ECG/ST	The ST depression in lead <n> is lower than the limit. Lead is not contiguous with any other lead.	numeric flashes and low alarm limit is highlighted, yellow alarm lamp, alarm tone

Alarm Message	From	Condition	Indication
* SVT	ECG/Arrhythmia	A run of supraventricular beats > the SVT run limit and heart rate > the SVT HR limit.	numeric flashes, yellow alarm lamp, alarm tone
*** Tachy (Pulse)	SpO ₂ , Pressure, cmResp	Pulse rate > the extreme tachy alarm limit.	numeric flashes, alarm limit is highlighted, red alarm lamp, alarm tone
*** Tachy/P xxx>yyy	SpO ₂ , Pressure, cmResp	This is the alternative alarm message for *** Tachy (Pulse) when the alarm text setting is Enhanced . Pulse rate > the extreme tachycardia alarm limit. xxx denotes the highest measured value; yyy is the tachycardia limit.	numeric flashes, alarm limit is highlighted, red alarm lamp, alarm tone
** Tblood High	C.O.	The blood temperature value has exceeded the high alarm limit.	numeric flashes, high alarm limit is highlighted, yellow alarm lamp, alarm tone
** Tblood Low	C.O.	The blood temperature value has fallen below the low alarm limit.	numeric flashes, low alarm limit is highlighted, yellow alarm lamp, alarm tone
** tcpCO ₂ High	tcGas	The tcpCO ₂ value has exceeded the high alarm limit.	numeric flashes, high alarm limit is highlighted, yellow alarm lamp, alarm tone
** tcpCO ₂ Low	tcGas	The tcpCO ₂ value has fallen below the low alarm limit.	numeric flashes, low alarm limit is highlighted, yellow alarm lamp, alarm tone
** tcpO ₂ High	tcGas	The tcpO ₂ value has exceeded the high alarm limit.	numeric flashes, high alarm limit is highlighted, yellow alarm lamp, alarm tone
** tcpO ₂ Low	tcGas	The tcpO ₂ value has fallen below the low alarm limit.	numeric flashes, low alarm limit is highlighted, yellow alarm lamp, alarm tone
* Tele Alarm ** Tele Alarm *** Tele Alarm	an assigned telemetry device	A telemetry device used for the patient is in an alarm condition. Check the detailed alarm information at the Information Center.	yellow or red alarm lamp and alarm tone
** <Temp Label> High	Temperature	The temperature has exceeded the high alarm limit.	numeric flashes and high limit is highlighted, yellow alarm lamp, alarm tone
** <Temp Label> Low	Temperature	The temperature has fallen below the low alarm limit.	numeric flashes and low limit is highlighted, yellow alarm lamp, alarm tone
* T-Mon Alarm ** T-Mon Alarm *** T-Mon Alarm	an assigned transport monitor	A transport monitor used for the patient is in an alarm condition. Check the detailed alarm information at the Information Center.	yellow or red alarm lamp and alarm tone
** TOFcnt High	NMT	TOFcnt value has exceeded the high alarm limit	numeric flashes and high limit is highlighted, yellow alarm lamp, alarm tone
* Vent Bigeminy	ECG/Arrhythmia	A dominant rhythm of N, V, N, V (N = supraventricular beat, V = ventricular beat)	numeric flashes, yellow alarm lamp, short yellow audible alarm
*** Vent Fib/Tach	ECG	Fibrillatory waveform (sinusoidal wave between 2 - 10 Hz) for 4 consecutive seconds.	numeric flashes, red alarm lamp, alarm tone

3 Patient Alarms and INOPs

Alarm Message	From	Condition	Indication
* Vent Rhythm ** Vent Rhythm	ECG/Arrhythmia	A dominant rhythm of adjacent Vs > the vent rhythm limit and ventricular heart rate < the V-Tach HR limit.	numeric flashes, yellow alarm lamp, short yellow audible alarm
* Vent Trigeminy	ECG/Arrhythmia	A dominant rhythm of N, N, V, N, N, V (N = supraventricular beat, V = ventricular beat).	numeric flashes, yellow alarm lamp, short yellow audible alarm
*** VTach	ECG/Arrhythmia	A run of PVCs ≥ the V-Tach run limit and heart rate > the V-Tach HR limit.	numeric flashes, red alarm lamp, alarm tone
*** xBrady xxx<yyy	Pressure, SpO ₂ , ECG	This is the alternative alarm message for *** Extreme Brady , when the alarm text setting is Enhanced . Heart rate < the extreme bradycardia alarm limit. xxx denotes the lowest measured value; yyy is the extreme bradycardia limit.	numeric flashes and alarm limit is highlighted, red alarm lamp, alarm tone
*** xTachy xxx>yyy	Pressure, SpO ₂ , ECG	This is the alternative alarm message for *** Extreme Tachy when the alarm text setting is Enhanced . Heart rate > the extreme tachycardia alarm limit. xxx denotes the highest measured value; yyy is the tachycardia limit.	numeric flashes, alarm limit is highlighted, red alarm lamp, alarm tone

Technical Alarm Messages (INOPs)

If an INOP interrupts monitoring and alarm detection, the measurement numeric will be replaced by **-?-**. If an INOP may lead to unreliable measurement values, a **?** appears next to the numeric.

The measurement labels and abbreviations for pressure, temperature, and SpO₂ INOP messages are explained in the individual measurement chapters.

Monitor INOPs

INOP Message, Indication	What to do
Bad MSL INOP tone	1) A Multi-Measurement Module with an incompatible software revision is connected to the monitor. This combination does not allow monitoring, OR 2) You cannot use this combination of monitor, Multi-Measurement Module and cable. Switch off the monitor and contact your service personnel.
Central: Tele Only INOP tone	System connectivity via telemetry device is limited (No alarms, only local numerics) when in companion mode and host monitor does not have system connectivity. Only telemetry device parameters can be displayed at central station.
Check Alarm Lamps INOP tone	Perform a visual check of the alarm lamp to establish whether there is a problem. Contact your service personnel to check the internal connections to the alarm lamps.
Check DrugSettings INOP tone	There was a problem loading the drug settings. Check that the settings are complete and correct.
!! Check ECG Source Yellow tone	The telemetry device and the monitor both have valid ECG signals. Unpair the telemetry device and the monitor if they are no longer used for the same patient.
!! Check Equipment INOP tone/Yellow tone	There is an equipment status dispute relating to one or more of the devices assigned to this patient. See the Equipment window for details.
Check Flex Texts INOP tone	Check the names of the monitor menus, for example the labels for screens, profiles, event or trend group names, before you resume monitoring. If they are unexpected, there may be a problem with the monitor software. Contact your service personnel.

INOP Message, Indication	What to do
Check Keyboard INOP tone	Perform a visual and functional check of the keyboard. Contact your service personnel.
Check Monitor Func INOP tone	Potential problem with alarm lamps, display or interfaces detected. Contact your service personnel.
Check Monitor Temp INOP tone	The temperature inside the monitor is too high. Check that the monitor ventilation is not obstructed. If the situation continues, contact your service personnel.
Check Mouse INOP tone	Perform a visual and functional check of the mouse input device. Contact your service personnel.
Check MSL Voltage INOP tone	There is a problem with the voltage of the Measurement Link (MSL). Contact your service personnel.
Check Network Conf INOP tone	The monitor is receiving network topology information from more than one source, e.g. the Database Server and an Application Server. Contact your service personnel.
!! Check Pairing Yellow tone	There is a problem with device pairing. Check that the monitor and telemetry device are correctly paired.
Check Passwords	There is a problem with the password settings. Contact your service personnel.
!! Check Patient ID Yellow tone	There is a mismatch between patient data in two connected devices. Resolve the mismatch to allow settings and data synchronization.
Check Screen Res. INOP tone	The Screen you have selected uses a resolution which is not supported by the display. The monitor will show a generic Screen instead until you select a different Screen. Contact your service personnel if you want the Screen deleted from the Profile(s) to avoid this in future.
Check Settings INOP tone	If this INOP appears, check the monitor and patient settings before you resume monitoring. If the settings are unexpected, there may be a problem with the monitor software. Contact your service personnel.
Check Touchscreen INOP tone	Perform a visual and functional check of the touch input device. Contact your service personnel.
Check Waves INOP tone	The options purchased with this monitor may not support the number of waves required to show the selected Screen, so some waves or high resolution trends are missing from the Screen. Select a different Screen with fewer waves. Contact your service personnel if you want the Screen deleted from the Profile(s) to avoid this in future.
Chk <Measurement Label> Settings	Synchronization of the settings for the measurement cited, has failed. Check that settings are appropriate for your patient.
Chk MSL Connection INOP tone	Check that the MSL cable is properly connected. If this is the case, try using another MSL cable, to check if your cable is defective. If this does not help, the device connected via the MSL cable may be defective, contact your service personnel.
Chk SyncOut Cable INOP tone	The ECG Sync is detecting an invalid signal, or the ECG Sync cable is disconnected.
Internal.Comm.Malf INOP tone	There is a problem with I2C Bus communication in the monitor. Contact your service personnel.
Meas. Deactivated	An X2/X3 has been connected to a host monitor (companion mode) and all derived measurements have been deactivated and/or measurements with a label conflict. The measurements can only be reactivated by disconnecting the measurement device from the host monitor.
!! More Bed Alarms !!! More Bed Alarms at Information Center	The monitor is associated with a telemetry device and is sending data to the Information Center via the telemetry device. There are currently more alarms at the bedside than can be transmitted to the Information Center.
More INOPs !! More INOPs !!! More INOPs	There is more than one technical alarm of the corresponding severity active on the devices that monitor this patient. For details check the information displayed at the Information Center.

3 Patient Alarms and INOPs

INOP Message, Indication	What to do
MSL Power High	The power consumption of the devices connected to the Measurement Link (MSL) cable is too high. If this situation continues, the MSL will be switched off. Contact your service personnel.
MSL Power Off INOP tone	The power consumption of the devices connected to the Measurement Link (MSL) cable was too high for too long and the MSL has been switched off. Contact your service personnel.
MSL Power Overload INOP tone	The power consumption of the devices connected to the Measurement Link (MSL) cable is much too high or there has been a short circuit. The MSL has been switched off. Contact your service personnel.
No Central Monit. INOP tone	There is a problem with the communication to the network. Central monitoring is currently not possible (no patient alarms or information). Check the connection. In case the connection is via a telemetry device, the current telemetry use model does not support central monitoring. Contact your service personnel.
No ECG at Central	The ECG measured with the monitor ECG is not being sent to the Information Center via the telemetry device.
OtherMon INOP !! OtherMon INOP !!! OtherMon INOP	Another monitor assigned to the patient (e.g. a transport monitor) is in an INOP condition. Check the detailed INOP information at the Information Center and resolve the INOP condition(s) at the other monitor.
Settings Malfunct INOP tone	The monitor cannot use the predefined settings for monitoring. Contact your service personnel.
Speaker Malfunct INOP tone	Contact your service personnel to check the speaker and the connection to the speaker.
SRR Incompatible INOP tone	The short range radio component has compatibility problems. Contact your service personnel.
SRR Interference INOP tone	The short range radio connection has interference from another device. Try using another channel.
SRR Invalid Chan INOP tone	The channel configuration of the Short Range Radio is invalid. Check channel and channel mask configuration.
SRR Malfunction INOP tone	Malfunction in the short range radio device. If the INOP persists contact your service personnel.
TAAP Disabled INOP tone	The currently selected telemetry configuration on the monitor does not allow connection of telemetry devices to the monitor.
Tele Config Unsupp INOP tone	Telemetry Workflow configuration not supported. Check revision and configuration of monitor and central.
Tele Equip Malf INOP tone	The telemetry device has a malfunction. Disconnect and reconnect the telemetry device. If the INOP reappears, replace the telemetry device.
Tele Incompatible	SRR-enabled telemetry device is not supported by this central software revision. Please check configuration.
Tele INOP !! Tele INOP !!! Tele INOP Severe yellow/red INOP tone	A telemetry device assigned to the patient is in an INOP condition. Check the detailed INOP information at the Information Center and resolve the INOP condition(s) at the telemetry device.
Tele Unsupported INOP tone	This telemetry device is not supported for direct connection to the monitor.
<TimerLabel>:TimeElapsed INOP tone	The time has expired for the timer indicated in the INOP text. Clearing the timer clears the INOP.
T-Mon INOP !! T-Mon INOP !!! T-Mon INOP INOP tone	A transport monitor assigned to the patient is in an INOP condition. Check the detailed INOP information at the Information Center and resolve the INOP condition(s) at the transport monitor.
TransportEquipment	The equipment is ready for transport. See the Equipment window for details.

INOP Message, Indication	What to do
Unsupported LAN INOP tone	There is a problem with the communication to the network and central monitoring is currently not possible. Check the connection. If the INOP persists, switch off the monitor and contact your service personnel.
User I/F Malfunc INOP tone	Perform a visual and functional check of all the monitor input devices. Contact your service personnel.

Battery INOPs

INOP Message, Indication	What to do
Batt Empty !! Batt Empty !!! Batt Empty INOP tone, battery LED flashes During this INOP, alarms cannot be paused or switched off.	The estimated remaining battery-powered operating time is less than 10 minutes. Replace the battery immediately. If the condition persists and the monitor is not connected to mains power, this INOP is re-issued two minutes after you acknowledge it.
Batt Extensn Malf INOP tone	There is a hardware error in the Battery Extension. Contact your service personnel.
Batt Incompat INOP tone	The battery cannot be used with this monitor. Replace with the correct battery as specified in this book.
Batt Low INOP tone	The estimated battery-powered operating time remaining is less than 20 minutes.
Batt Malfunction INOP tone, battery LED flashes During this INOP, alarms cannot be paused or switched off unless the monitor is connected to mains power.	The monitor cannot determine the battery status. If this INOP persists, replace the faulty battery. If the condition persists and the monitor is not connected to mains power, this INOP is re-issued two minutes after you acknowledge it. Place the battery in a different monitor or in a battery charger. If the same INOP is shown, contact your service personnel.
Charger Malfunc INOP tone, battery LED may flash	There is a problem with the battery charger in the monitor. Connect the monitor to mains power and contact your service personnel.
Check Batt Temp INOP tone	The temperature of one or both batteries is too high. Check that ventilation openings (if applicable) are not blocked and monitor is not exposed to heat.
Chk MSL Connection	Check the MSL connection between the monitor and the battery extension for damage or loose connections. Check also if a second Multi-Measurement Module has been connected accidentally (e.g. in companion mode).
ExtBat Empty !! ExtBat Empty !!! ExtBat Empty INOP tone, battery LED flashes During this INOP, alarms cannot be paused or switched off.	The estimated battery-powered operating remaining time is less than 10 minutes. Replace the battery in the battery extension immediately. If the condition persists and the monitor is not connected to mains power, this INOP is re-issued two minutes after you acknowledge it.
ExtBat Incompat	The battery in the battery extension cannot be used. Replace with the correct battery as specified in this book.
ExtBat Low	The estimated battery-powered operating time remaining is less than 20 minutes.
ExtBat Malfunction INOP tone, battery LED flashes During this INOP, alarms cannot be paused or switched off unless the monitor is connected to mains power.	The monitor cannot determine the status of the battery in the battery extension. If this INOP persists, replace the faulty battery in the battery extension. If the condition persists and the monitor is not connected to mains power or a host monitor, this INOP is re-issued two minutes after you acknowledge it.

3 Patient Alarms and INOPs

INOP Message, Indication	What to do
ExtBat Missing	There is no battery in the Battery Extension
!! Insert Battery Severe yellow INOP tone During this INOP, alarms cannot be paused or switched off.	MX100/X3/X2/MP2 only: There is no battery in the battery compartment. You cannot operate the monitor on AC mains or battery extension when no battery is in the compartment. Load a battery immediately.
MSL Power High	The power consumption of the devices connected to the Battery Extension is too high. If this situation continues, the Battery Extension will be switched off. Contact your service personnel.
MSL Power Off	The power consumption of the devices connected to the Battery Extension was too high for too long. The Battery Extension has been switched off. Contact your service personnel.

Multi-Measurement Module, Measurement Extensions and Module Rack INOPs

INOP Message, Indication	What to do
FMS Unplugged INOP tone	Make sure that the Module Rack is connected to the monitor. All Module Rack measurements are off while the Module Rack is unplugged.
FMS Unsupported	An FMS connected to the Measurement Link (MSL) is incompatible or not supported in this configuration. Contact your service personnel.
FMX Unplugged	Make sure that the Module Rack is connected to the monitor. All Module Rack measurements are off while the Module Rack is unplugged.
FMX Unsupported	An FMX connected to the Measurement Link (MSL) is incompatible or not supported in this configuration. Contact your service personnel.
<Measurement Label> Unsupported	A plug-in module is incompatible or not supported in this configuration. Contact your service personnel.
MMS Msmt Malf INOP tone	Measurement hardware in Multi-Measurement Module or Measurement Extension is defective. Unplug the Multi-Measurement Module and Measurement Extension and plug them in again after a few seconds. If the INOP persists, contact your service personnel.
MMS Unplugged INOP tone	Make sure that the Multi-Measurement Module is connected to the monitor. All Multi-Measurement Module measurements are off while the Multi-Measurement Module is unplugged.
MMS Unsupported	An MMS connected to the Measurement Link (MSL) is incompatible or not supported in this configuration. Contact your service personnel.
MMX Msmt Malf INOP tone	Measurement hardware in Multi-Measurement Module or Measurement Extension is defective. Unplug the Multi-Measurement Module and Measurement Extension and plug them in again after a few seconds. If the INOP persists, contact your service personnel.
MMX Unplugged INOP tone	Make sure that the Multi-Measurement Module is connected to the monitor. All Multi-Measurement Module measurements are off while the Multi-Measurement Module is unplugged.
MMX Unsupported	An MMX connected to the Measurement Link (MSL) is incompatible or not supported in this configuration. Contact your service personnel.
MON Msmt Malf INOP tone	A measurement module or measurement hardware in the monitor or a connected X2/X3 companion monitor is defective. Restart the monitor. If the INOP persists, contact your service personnel.
MSL Device Unsupp. INOP tone	A device connected to the Measurement Link (MSL) is unknown or a Multi-Measurement Module or Module Rack are incompatible or not supported in this configuration. Contact your service personnel.
Msmt Ext. Detached INOP tone	The Measurement Extension has been disconnected from the Multi-Measurement Module.
Msmt Ext. Malf INOP tone	Loss of communication between the Multi-Measurement Module and the Measurement Extension. Contact your service personnel.
Msmt Ext. Unsupp INOP tone	The Measurement Extension is not supported by your monitor. Contact your service personnel.

INOP Message, Indication	What to do
Msmt Ext.Unpowered INOP tone	The Measurement Extension cannot operate while the Multi-Measurement Module is running on battery power.
X2 Unplugged INOP tone	Make sure that the Multi-Measurement Module is connected to the monitor. All Multi-Measurement Module measurements are off while the Multi-Measurement Module is unplugged.
X2 Unsupported	An X2 connected to the Measurement Link (MSL) is incompatible or not supported in this configuration. Contact your service personnel.
X3 Unplugged INOP tone	Make sure that the Multi-Measurement Module is connected to the monitor. All Multi-Measurement Module measurements are off while the Multi-Measurement Module is unplugged.
X3 Unsupported	An X3 connected to the Measurement Link (MSL) is incompatible or not supported in this configuration. Contact your service personnel.

ECG, Arrhythmia, QT and ST INOPs

INOP Message, Indication	What to do
Cannot Analyze ECG INOP tone	The arrhythmia algorithm cannot reliably analyze the ECG data. Check the ECG signal quality of the selected primary and secondary leads. If necessary, improve lead position or reduce patient motion.
Cannot Analyze QT	The QT algorithm cannot generate a valid QT value for more than 10 minutes, or 1 minute in the initial phase.
Cannot Analyze ST	The ST algorithm cannot generate a valid ST value. Possible causes are large variations in the measured ST values for consecutive beats, or ventricular paced beats. Review the ECG signal quality and the ST measurement points. If the patient has a ventricular pacemaker, ST analysis is not possible.
Cannot Analyze STE	The STE algorithm cannot generate valid ST elevation values. Possible causes are large variations in the measured ST values for consecutive beats, or ventricular paced beats. Review the ECG signal quality and the ST measurement points.
ECG Check Cable INOP tone	Defective ECG cable was detected, which can result in inaccurate ECG signals and measurements, e.g. ST numeric, displayed on the monitor. Check trunk cable and lead set for damage and replace if INOP persists.
ECG Equip Malf Numeric is replaced by -?- INOP tone	Contact your service personnel. The ECG hardware is faulty.
<ECG Lead> Lead Off !! <ECG Lead> Lead Off !!! <ECG Lead> Lead Off If no ECG lead is measurable, numeric is replaced by -?- INOP tone	Not all the required leads for ECG monitoring are connected. Check the ECG connections and make sure that the electrode indicated by <ECG lead> is attached [e.g. RA, LA, LL, RL, V or C electrodes]. With EASI lead placement all 5 electrodes must be connected, and with Hexad lead placement all 6 electrodes must be connected.
ECG Leads Off !! ECG Leads Off !!! ECG Leads Off Numeric is replaced by -?- INOP tone	Check that all of the required ECG leads are attached, and that none of the electrodes have been displaced. The INOP may also be caused by a saturated or overloaded ECG amplifier.
ECG Noisy Elec <ECG Lead>	The ECG signal from the named ECG electrodes [RA, LA, LL, RL, V (or C)] is noisy. Check the ECG connections and make sure that the electrode indicated is attached. Depending on the software version in the measurement device, this INOP can also indicate a defective ECG cable (see INOP ECG Check Cable).
ECG Noisy Signal INOP tone	The ECG signal is too noisy. Check that the electrodes are properly placed and have not dried out. Remove any possible sources of signal noise (such as power cords) from the area around the cable and the patient. The ECG signal may be saturated or overloaded.

3 Patient Alarms and INOPs

INOP Message, Indication	What to do
ECG/Arrh AlarmsOff !! ECG/Ar AlarmsOff	All ECG alarms have been switched off, or the HR alarm source is not ECG. To resume ECG alarm generation, switch ECG alarms on or select ECG as the alarm source.
Some ECG AlarmsOff	This message appears (if configured to do so) when the on/off settings of the yellow arrhythmia alarms differ from the current Profile.
SyncOut Equip Malf INOP tone	There is a problem with the device connected to the ECG Out connector. Contact your service personnel.

Pulse INOPs

INOP Message, Indication	What to do
Pulse Not Alarming Numeric is replaced by -?- INOP tone	Pulse has no alarming because the system pulse is measured by an external device. Select another pulse source to enable pulse alarming.

Resp INOPs

INOP Message, Indication	What to do
Resp Equip Malf Numeric is replaced by -?- INOP tone	Contact your service personnel. The RESP hardware is faulty.
Resp Erratic Numeric is replaced by -?-	The monitor has detected too many artifacts in the measured Resp signal. Check that the RA and LL electrodes are correctly attached and have not dried out.
Resp Leads Off Numeric is replaced by -?- INOP tone	Not all the required leads for Resp monitoring are attached. Make sure that the RA, LA, and LL leads are attached.

NBP INOPs

INOP Message, Indication	What to do
!! Cuff Not Deflat !!! Cuff Not Deflat Numeric is displayed with a -?- Severe yellow/red INOP tone During this INOP, alarms cannot be paused or switched off.	Remove the cuff from the patient. Make sure that the tubing is not kinked or twisted and that the correct patient category is selected. Try repeating the measurement. You can acknowledge the INOP, but the INOP message remains visible until the next NBP measurement is started or the Stop All SmartKey is selected. [Adult or pediatric patients: The NBP cuff pressure has exceeded 15 mmHg (2 kPa) for more than 3 minutes. Neonatal patients: The NBP cuff pressure has exceeded 5 mmHg (0.7 kPa) for more than 90 seconds.]
!! Cuff Overpress !!! Cuff Overpress Numeric is displayed with a -?- Severe yellow/red INOP tone During this INOP, alarms cannot be paused or switched off.	The NBP cuff pressure exceeds the overpressure safety limits. Remove the cuff from the patient. Make sure that the tubing is not kinked or twisted and that the correct patient category is selected. Try restarting the measurement. You can acknowledge this INOP, but the INOP message remains visible until the next measurement is started or the Stop All SmartKey is selected.
NBP Check Cuff Numeric is replaced by -?- INOP tone	Check that a cuff is connected, that it is applied properly to the patient, and that no leakage can be observed. The maximum inflation time has been exceeded. You can acknowledge this INOP, but the INOP message remains visible until the next measurement is started or the Stop All SmartKey is selected.

INOP Message, Indication	What to do
NBP Deactivated INOP tone	The NBP measurement label in the measurement device has been deactivated by deactivating the label in the Measurement Selection window. The measurement automatically disappears from the display. To switch the measurement on again, reactivate the measurement label in the Measurement Selection window.
NBP Equip Malf Numeric is replaced by -?- INOP tone	Remove the cuff from the patient. The NBP hardware is faulty. Contact your service personnel. You can acknowledge this INOP, but the INOP message remains visible until the next measurement is started or the Stop All SmartKey is selected.
NBP Interrupted Numeric is replaced by -?- INOP tone	Check the tubing and cuff for leakages or kinks. Check that you are using the correct cuff size and placement, and that the correct patient category is selected. Try restarting the measurement. If the INOP occurs repeatedly, contact your service personnel. You can acknowledge this INOP, but the INOP message remains visible until the next measurement is started or the Stop All SmartKey is selected. This INOP arises when the measurement needed longer than the maximum time for inflation, deflation or the total measurement.
NBP Measure Failed Numeric may be replaced by -?- INOP tone	Check that you are using the correct cuff size and placement, and that the correct patient category is selected. Try restarting the measurement. You can acknowledge this INOP, but the INOP message remains visible until the next measurement is started or the Stop All SmartKey is selected. Check the condition and suitability of the patient for NBP monitoring. Use another cuff to continue measuring.

Temperature INOPs

INOP Message, Indication	What to do
T1, T2, T3, T4 INOPs	See <Temp Label> INOPs
Tamb INOPs	See <Temp Label> INOPs
Tart INOPs	See <Temp Label> INOPs
Tblad INOPs	See <Temp Label> INOPs
Tcereb INOPs	See <Temp Label> INOPs
Tcore INOPs	See <Temp Label> INOPs
ΔTemp Chk Sources INOP	One of the measurements required to perform the calculation is not available. Check that both temperature measurements are available.
ΔTemp Chk Units INOP	The monitor has detected a conflict in the units of the measurements. Check the unit settings.
<Temp Label> Deactivated INOP tone	A Temp measurement label in the measurement device has been deactivated, either by connecting a Pressure transducer in the shared Press/Temp socket, or by deactivating the label in the Measurement Selection window. The measurement automatically disappears from the display. To switch the measurement on again, either reconnect a Temp transducer or reactivate the measurement label in the Measurement Selection window.
<Temp Label> Equip Malf Numeric is replaced by -?- INOP tone	Contact your service personnel. The temperature hardware is faulty.
<Temp Label> NoTransducer Numeric is replaced by -?- INOP tone	Make sure the Temp probe is connected to the Multi-Measurement Module or module. If you acknowledge this INOP, the measurement will be switched off.
<Temp Label> Overrange Numeric is replaced by -?- INOP tone	Try changing the application site of the transducer. [The temperature is less than -1°C, or greater than 45°C.]

3 Patient Alarms and INOPs

INOP Message, Indication	What to do
<Temp Label> Unplugged INOP tone	A Temp measurement label has been deactivated, either by unplugging a module, or by deactivating the label in the Measurement Selection window. The measurement automatically disappears from the display. To switch the measurement on again, either replug the module or reactivate the measurement label in the Measurement Selection window.
Tesoph INOPs	See <Temp Label> INOPs
Tfoley INOPs	See <Temp Label> INOPs
Tnaso INOPs	See <Temp Label> INOPs
Trect INOPs	See <Temp Label> INOPs
Tskin INOPs	See <Temp Label> INOPs
Ttymp INOPs	See <Temp Label> INOPs
Tven INOPs	See <Temp Label> INOPs
Tvesic INOPs	See <Temp Label> INOPs

Tympanic Temp INOPs

INOP Message, Indication	What to do
<iTemp Label> CalRequired INOP tone	The thermometer requires calibration. Contact your service personnel.
<iTemp Label> Incompat. Numeric is replaced by -?- INOP tone	The thermometer firmware is not supported by the monitor software.
<iTemp Label> Malfunction Numeric is replaced by -?- INOP tone	<ul style="list-style-type: none"> The thermometer or the interface board are defective. Check the thermometer on another monitor - if the same INOP occurs, replace the thermometer. If not, connect another thermometer to this monitor. If the problem persists, the interface board has a problem. Contact your service personnel. The wrong thermometer type is selected in Service Mode. Contact your service personnel.
<iTemp Label> Meas Failed Numeric is replaced by -?- INOP tone	The ambient temperature is out of range. If the ambient temperature is within the valid range, check the thermometer. Try picking up a new probe cover. If the problem persists replace the thermometer and contact your service personnel.
<iTemp Label> Overrange Numeric is replaced by -?- INOP tone	The measured temperature is out of range. If the actual temperature is within the valid range, check with another thermometer.

SpO2 INOPs

INOP Message, Indication	What to do
ΔSpO₂ Chk Sources Numeric is replaced by -?- INOP tone	One of the measurements required to perform the calculation is not available. Check that both SpO ₂ measurements are available.
ΔSpO₂ Chk Units Numeric is replaced by -?- INOP tone	The monitor has detected a conflict in the units of the measurements. Check the unit settings.
<SpO₂ Label> Deactivated INOP tone	The SpO ₂ measurement label in the measurement device has been deactivated by deactivating the label in the Measurement Selection window. The measurement automatically disappears from the display. To switch the measurement on again, reactivate the measurement label in the Measurement Selection window.

INOP Message, Indication	What to do
<SpO₂ Label> Equip Malf Numeric is replaced by -?- INOP tone	The Multi-Measurement Module or module is faulty. Unplug and replug the Multi-Measurement Module or module. If the INOP persists, contact your service personnel.
<SpO₂ Label> Erratic Numeric is replaced by -?- INOP tone	Check the sensor placement. Try another adapter cable and sensor. If the INOP persists, contact your service personnel.
<SpO₂ Label> Extd.Update Numeric is displayed with a ? (questionable numeric)	The update period of displayed values is extended due to an NBP measurement on the same limb or an excessively noisy signal.
<SpO₂ Label> Interference Numeric is replaced by -?- INOP tone	There is too much interference, caused by a high level of ambient light and/or electrical interference. Cover the sensor to minimize ambient light. If the INOP persists, make sure that the sensor cable is not damaged or positioned too close to power cables.
<SpO₂ Label> Low Perf Numeric is displayed with a ? (questionable numeric)	Accuracy may be compromised due to very low perfusion. Stimulate circulation at sensor site. If INOP persists, change the measurement site.
<SpO₂ Label> No Pulse Numeric is replaced by -?- INOP tone	Check the perfusion at measurement site. If necessary, stimulate circulation or change measurement site. If the INOP is due to NBP measurement on the same limb, wait until the NBP measurement is finished.
<SpO₂ Label> No Sensor Numeric is replaced by -?- INOP tone	Make sure the SpO ₂ sensor is connected. If the INOP persists, try another adapter cable and sensor. If you acknowledge this INOP, the measurement will be switched off.
<SpO₂ Label> NoisySignal Numeric is replaced by -?- INOP tone	Excessive patient movement or electrical interference is causing irregular pulse patterns. Try to reduce patient movement or to relieve the cable strain on the sensor.
<SpO₂ Label> Poor Signal Numeric is displayed with a ? (questionable numeric)	The signal condition of the SpO ₂ measurement is poor and measurement accuracy may be compromised. If the INOP persists, consider changing the application site or using another sensor.
<SpO₂ Label> Pulse? Numeric is replaced by -?- INOP tone	The detectable pulsations of the SpO ₂ signal are outside the specified pulse rate range.
<SpO₂ Label> Searching Numeric is unavailable	SpO ₂ is analyzing the patient signal to derive Pulse, SpO ₂ and Perf values. Please wait until the search analysis is complete.
<SpO₂ Label> Sensor Malf Numeric is replaced by -?- INOP tone	The SpO ₂ sensor or adapter cable is faulty. Try another adapter cable and sensor. If the INOP persists, contact your service personnel.
<SpO₂ Label> Sensor Off Numeric is replaced by -?- INOP tone	The SpO ₂ sensor is not properly applied to the patient. Apply the sensor following the instructions supplied by the manufacturer.
<SpO₂ Label> Unkn.Sensor Numeric is replaced by -?-	The connected sensor or adapter cable is not supported by the SpO ₂ measurement. Use only specified sensors and cables.
<SpO₂ Label> Unplugged Numeric is replaced by -?- INOP tone	An SpO ₂ measurement label has been deactivated, either by unplugging a module, or by deactivating the label in the Measurement Selection window. The measurement automatically disappears from the display. To switch the measurement on again, either replug the module or reactivate the measurement label in the Measurement Selection window.
<SpO₂ Label> Upgrade Numeric is replaced by -?-	The SpO ₂ measurement is currently in upgrade mode. Monitoring is not possible in this mode.

Pressure INOPs

INOP Message, Indication	What to do
ABP INOPs	See <Press Label> INOPs
Ao INOPs	See <Press Label> INOPs
ART INOPs	See <Press Label> INOPs
BAP INOPs	See <Press Label> INOPs
CPP Chk Sources Numeric is replaced by -?- INOP tone	Not all measurements or values required to perform the calculation are available. Check the measurement sources. Acknowledging this INOP switches CPP off.
CPP Chk Units Numeric is replaced by -?-	The monitor has detected a conflict in the units used for this calculation. Check the unit settings.
CPP Disabled	CPP has been disabled, either in the setup in Configuration mode, or by loading settings with CPP disabled. Enable CPP in the current profile to clear the INOP.
CVP INOPs	See <Press Label> INOPs
FAP INOPs	See <Press Label> INOPs
IAP INOPs	See <Press Label> INOPs
IC1 / IC2 INOPs	See <Press Label> INOPs
ICP INOPs	See <Press Label> INOPs
LAP INOPs	See <Press Label> INOPs
LFP INOPs	See <Press Label> INOPs
P / P1 / P2 / P3 / P4 INOPs	See <Press Label> INOPs
Pa1 / Pa2 / Pa3 / Pa4 INOPs	See <Press Label> INOPs
PAP INOPs	See <Press Label> INOPs
Ppo INOPs	See <Press Label> INOPs
Ppr INOPs	See <Press Label> INOPs
PPVbad <PressLabel> Signal Numeric is replaced by -?-	The arterial pressure source selected for PPV is not providing a pulsatile signal.
PPV bad Signal at Information Center Numeric is replaced by -?-	The arterial pressure source selected for PPV is not providing a pulsatile signal.
PPV Chk Sources Numeric is replaced by -?-	The arterial pressure source selected for PPV is unplugged or switched off. When this INOP has displayed for 1 minute PPV will be switched off.
<Press Label> Artifact Numeric questionable	A non-physiological event (flush or blood sample) is detected. A resulting limit alarm or non-pulsatile INOP will be suppressed.
<Press Label> Change Scale	Increase the scale for the pressure wave.
<Press Label> Deactivated INOP tone	A Pressure measurement label in the measurement device or extension has been deactivated, either by connecting a Temp transducer in the shared Press/Temp socket, or by deactivating the label in the Measurement Selection window. The measurement automatically disappears from the display. To switch the measurement on again, either reconnect a Pressure transducer or reactivate the measurement label in the Measurement Selection window.
<Press Label> Equip Malf Numeric is replaced by -?- INOP tone	Contact your service personnel. The pressure hardware is faulty.

INOP Message, Indication	What to do
<Press Label> No Pulse Pulse numeric is replaced by -?- INOP tone	This INOP can only arise when a pressure is selected as the pulse source. It occurs when the pulse rate being measured is less than 25 beats per minute or the amplitude is less than three mmHg. Check the catheter and connections to the patient.
<Press Label> No Transducer Numeric is replaced by -?- INOP tone	Make sure that the pressure transducer is connected to the measurement device or module. If you acknowledge this INOP, the measurement will be switched off.
<Press Label> Noisy Signal Pulse numeric is replaced by -?- INOP tone	This INOP can only arise when a pressure is selected as the pulse source. It occurs when the pulse detector finds a pulse rate above 350 bpm. This is usually caused by movement artifact or electrical interference.
<Press Label> Overrange Numeric is replaced by -?- INOP tone	Possible causes are a measured pressure above the allowed pressure range, or a broken wire to the transducer. Make sure that the measurement has been properly prepared and zeroed, and that the transducer is level with the heart. If this INOP persists, try another transducer.
!!! <Press Label> Overrange Numeric is replaced by -?- Red INOP tone	Possible causes are a measured pressure below the allowed pressure range, or a broken wire to the transducer. Make sure that the measurement has been properly prepared and zeroed, and that the transducer is level with the heart. If this INOP persists, try another transducer.
<Press Label> Unplugged INOP tone	A Pressure measurement label has been deactivated, either by unplugging a module, or by deactivating the label in the Measurement Selection window. The measurement automatically disappears from the display. To switch the measurement on again, either replug the module or reactivate the measurement label in the Measurement Selection window.
<Press Label> Zero+Check Cal Numeric is replaced by -?-	Perform a zero and check the calibration of the transducer.
Pv1 / Pv2 / Pv3 / Pv4 INOPs	See <Press Label> INOPs
RAP INOPs	See <Press Label> INOPs
RFP INOPs	See <Press Label> INOPs
SCP INOPs	See <Press Label> INOPs
UAP INOPs	See <Press Label> INOPs
UBP INOPs	See <Press Label> INOPs
UVP INOPs	See <Press Label> INOPs

CO2 INOPs

INOP Message, Indication	What to do
CO₂ Alarm Suppress	CO ₂ alarms will be paused until first breath is detected.
CO₂ Auto Zero If the Autozero lasts > 15 sec, the numeric is replaced by -?- and an INOP tone sounds.	The automatic zero calibration is in progress. This typically takes 10 seconds. During this time the CO ₂ values may not be updated, or they may be replaced by -?-. Wait until the zero calibration is complete to resume monitoring.
CO₂ Cal Failed Numeric is replaced by -?- INOP tone	Make sure that the Cal cell was changed between CAL1 and CAL2. Repeat the calibration. If the INOP reappears, try another transducer. If the INOP persists, contact your service personnel.
CO₂ Cal Mode CO ₂ numeric displays current CO ₂ value for accuracy check	Currently no calibration is running. Accuracy can be checked by placing the transducer on the two cells of the calstick and starting calibration. To start monitoring, leave Cal. Mode.

3 Patient Alarms and INOPs

INOP Message, Indication	What to do
CO₂ Cal Running Numeric is replaced by -?-	Wait until calibration is finished.
CO₂ Cannot Meas Numeric is replaced by -?- INOP tone	CO ₂ value is invalid/unavailable for an unexpected long period of time. Check the sensor placement. Try another sensor. If the INOP persists, contact your service personnel.
CO₂ Change Scale	The CO ₂ wave is clipped. Select a more appropriate wave scale to display the whole wave.
CO₂ Check Cal Numeric is replaced by -?- INOP tone	The CO ₂ value is outside the measurement range. Perform an accuracy check for both calstick cells and, if necessary, recalibrate the transducer.
CO₂ Check Tubing	There is a problem with the CO ₂ tubing. Check for leakages and replace the tubing if necessary. Disconnect the sensor and connect it again after a few seconds. If the INOP persists, contact your service personnel.
CO₂ Chk Adapter Numeric is replaced by -?- INOP tone	Check that the sensor is connected to the airway adapter, clean the airway adapter, if necessary. Perform a zero calibration. If the INOP persists, contact your service personnel.
CO₂ Deactivated INOP tone	The CO ₂ measurement label in the measurement device has been deactivated by deactivating the label in the Measurement Selection window. The measurement automatically disappears from the display. To switch the measurement on again, reactivate the measurement label in the Measurement Selection window.
CO₂ Equip Malf Numeric is replaced by -?- INOP tone	The measurement hardware is faulty. Unplug and replug the Multi-Measurement Module with Extension or the plug-in module. If you are using the mainstream method, unplug and replug the transducer or try another transducer. If the INOP persists, contact your service personnel.
CO₂ No Sensor from M3014A or 867185 Numeric is replaced by -?- INOP tone	There is no CO ₂ sensor connected. If you acknowledge this INOP the CO ₂ measurement will be switched off.
CO₂ No Tubing Numeric is replaced by -?- INOP tone	Either the sample line is disconnected, or an incorrect line is attached. Check the connection. If necessary, connect another sample line (Use only the approved accessories). If you acknowledge this INOP, the measurement will be switched off.
CO₂ NoTransducer from mainstream CO ₂ (except M3014A and 867185) Numeric is replaced by -?- INOP tone	There is no CO ₂ transducer connected. If you replace the transducer, the new transducer must be calibrated. If you acknowledge this INOP the CO ₂ measurement will be switched off.
!! CO₂ Occlusion !!! CO₂ Occlusion Numeric is replaced by -?- INOP tone	The sample line or exhaust tube is blocked. Check the tubing, then disconnect and reconnect the sample line. If the INOP persists, connect a new sample line.
CO₂ Overrange Numeric is replaced by -?- INOP tone may be issued	The CO ₂ value is higher than the measurement range. If you suspect a false high value, contact your service personnel.
CO₂ Pump Off Numeric is replaced by -?-.	The pump has been switched off for fifteen minutes. To switch it on again, select Pump On in the Setup CO₂ menu.
CO₂ Purging Numeric is replaced by -?- INOP tone	The Filterline is being purged to remove an occlusion in the line or airway adapter. If the occlusion is removed, the INOP will disappear. If not, the INOP CO₂ Occlusion is displayed.
CO₂ Sens Warmup Numeric is replaced by -?- Microstream CO ₂ : INOP tone Mainstream CO ₂ : no INOP tone	Wait until the sensor reaches operating temperature and the INOP disappears.

INOP Message, Indication	What to do
CO₂ Sensor Incomp Numeric is replaced by -?- INOP tone	The sensor or sensor type is unsupported, unknown or not supported by your software revision. Replace the sensor.
CO₂ Sensor Malf Numeric is replaced by -?- INOP tone	The sensor is defective. Replace the sensor.
CO₂ Upgrade FW Numeric is replaced by -?- INOP tone	The software in the Measurement Extension does not match the software in the Multi-Measurement Module. Contact your service personnel.
CO₂ Wait Cal2 Numeric is replaced by -?-	Calibration on the first calstick cell is complete. Place the transducer on the other calstick cell and start the CAL2 calibration cycle.
CO₂ Zero Failed Numeric is replaced by -?- INOP tone	An error occurred during the last zero calibration. Check the airway adapter and clean, if necessary. Perform another zero calibration. If the INOP persists, contact your service personnel.
CO₂ Zero Running	Wait until zero calibration is finished.
CO₂ ZeroRequired Numeric is replaced by -?- INOP tone	Perform zero calibration for the CO ₂ sensor. If the INOP persists, contact your service personnel.
IPI Check Pat. Age	For Adult patients: a date of birth has been entered that results in a calculated patient age of less than 12 years. Enter correct date of birth or, if patient is pediatric, correct patient category. For pediatric patients: either no date of birth has been entered (it is required for calculation of IPI for pediatric patients) or the calculated age is below 1 year or above 12 years. Check that correct date of birth is entered.
IPI Check Sources	The IPI numeric cannot be provided as one or more of the measurement sources required for IPI is not available. Check availability of etCO ₂ , awRR, SpO ₂ , and pulse rate.
IPI Neo Patient ?	Check patient category. The IPI numeric is not available for neonatal patients.

SO₂ INOPs

INOP Message, Indication	What to do
<SO₂ Label> Cal Failed Numeric is replaced by -?- INOP tone	The calibration failed. Check the catheter-to-Optical-Module connection. Manually restart the calibration. Try another catheter and Optical Module. If the catheter is already inserted, perform an in-vivo calibration.
<SO₂ Label> Cal Required Numeric is replaced by -?- INOP tone	There is no valid calibration data in the Optical Module. Perform either a pre-insertion or an in-vivo calibration.
<SO₂ Label> Cannot Meas Numeric is replaced by -?- INOP tone	The signal is out of the normal range, and no oxygen saturation can be derived. Perform an in-vivo calibration. If the INOP persists, try another Optical Module and catheter.
<SO₂ Label> Conn OptMod Numeric is replaced by -?- INOP tone	The Optical Module was disconnected during data storage. Reconnect the Optical Module for at least 20 seconds.
<SO₂ Label> Equip Malf Numeric is replaced by -?- INOP tone	The SO ₂ /SvO ₂ Module or Optical Module is faulty. Unplug and replug the Optical Module and SO ₂ /SvO ₂ module. Exchange the modules. If the INOP persists, contact your service personnel.
<SO₂ Label> Incompat. INOP tone	The SO ₂ Module or Optical Module is not supported. Contact your service personnel.

3 Patient Alarms and INOPs

INOP Message, Indication	What to do
<SO ₂ Label> In-Vivo Cal Numeric is replaced by -?- INOP tone	The in-vivo calibration is not yet complete. Lab values must be stored to the Optical Module to complete the calibration. Either continue with the next steps of the current calibration or recall the previous calibration.
<SO ₂ Label> Light Intens Numeric is replaced by -?- INOP tone	The intensity changed considerably since the last light intensity calibration. This may indicate that the catheter tip is positioned against a blood vessel wall or that there is low blood flow. Reposition the catheter (and perform a Light Intensity Calibration).
<SO ₂ Label> Low Light Numeric is replaced by -?- INOP tone	The optical signal levels are too low. Check that the catheter is either in the optical reference or inserted into the patient. Check the catheter-to-Optical Module connection. If INOP persists, try another catheter and Optical Module.
<SO ₂ Label> No OptMod Numeric is replaced by -?- INOP tone	Connect the Optical Module. If the INOP persists, try another Optical Module. Acknowledging this INOP switches the measurement off.
<SO ₂ Label> OptMod Malf	The Optical Module memory is faulty, and calibration data cannot be stored for transport or during power failure. If this capability is needed, use another Optical Module.
<SO ₂ Label> Unplugged Numeric is replaced by -?- INOP tone	Measurement switched on and SO ₂ /SvO ₂ module unplugged from the rack.
<SO ₂ Label> Upgrade INOP tone	The SO ₂ module is currently in upgrade mode. Monitoring is not possible in this mode.
<SO ₂ Label> Warmup Numeric is replaced by -?-	The Optical Module has not yet reached the operating temperature. Wait a few minutes until warm-up is finished.

C.O. INOPs

INOP Message, Indication	What to do
C.O. Deactivated INOP tone	The Cardiac Output measurement label in the measurement device has been deactivated by deactivating the label in the Measurement Selection window. The measurement automatically disappears from the display. To switch the measurement on again, reactivate the measurement label in the Measurement Selection window.
C.O. Equip Malf Numeric is replaced by -?- INOP tone	There is a problem with the C.O. hardware. Contact your service personnel.
C.O. Unplugged Numeric is replaced by -?- INOP tone	Plug in the C.O. module. Acknowledging this INOP switches off the measurement.
CCI No BSA CCI numeric unavailable INOP tone	CCI cannot be calculated because the patient's body surface area is unknown. Enter the patient weight and height to provide the BSA for CCI calculation.
CCO BadPressSignal Numeric is replaced by -?- INOP tone	The arterial pressure wave can currently not be used for pulse contour calculation for CCO or CCI measurement. Possible causes are air bubbles in the tubing or a physiological condition, for example severe arrhythmia.
CCO No Calibration Numeric is replaced by -?-	The CCO measurement is currently not calibrated.
CCO No <Press Label> Numeric is replaced by -?- INOP tone may sound	CCO/CCI cannot be calculated. Make sure that the pressure chosen in the Setup CCO menu under CCO from matches the pressure measured with the arterial catheter for CCO measurement. A pressure from an external device cannot be used. Select another pressure label, either ABP, Ao, ART, BAP, FAP, or UAP.

INOP Message, Indication	What to do
CCO No Press at Information Center	CCO/CCI cannot be calculated. Make sure that the pressure chosen in the Setup CCO menu under CCO from matches the pressure measured with the arterial catheter for CCO measurement. A pressure from an external device cannot be used. Select another pressure label, either ABP, Ao, ART, BAP, FAP, or UAP.
CCO Not Supported Numeric is replaced by -?- INOP tone	A catheter for transpulmonary C.O. measurements has been unplugged and replaced with a Right Heart C.O. catheter, or the measurement mode has been changed manually. Acknowledging this INOP switches the measurement off.
CCO Overrange CCI Overrange Numeric is replaced by -?- INOP tone	The measured CCO or CCI value is not within the specified range for CCO/CCI measurement.
CCO Press Invalid at Information Center	The arterial pressure selected for pulse contour calculation for CCO is available but currently invalid. Make sure the pressure transducer is connected and the zero calibration is valid.
CCO <Press Label> Invalid Numeric is replaced by -?- INOP tone may sound	The arterial pressure selected for pulse contour calculation for CCO is available but currently invalid. Make sure the pressure transducer is connected and the zero calibration is valid.
CCO PressOverrange Numeric is replaced by -?- INOP tone	The mean value of the arterial pressure values used for pulse contour calculation for CCO is below 0 mmHg or above 300 mmHg.
CCO PulseOverrange Numeric is replaced by -?- INOP tone	The pulse rate of the pressure used for pulse contour calculation for CCO is below 30 bpm or above 240 bpm.
CCO Recalibrate Numeric is replaced by -?- INOP tone	The most recent CCO or CCI calibration was made over 8 hours ago or the arterial pressure measurement used for CCO calculation has been zeroed after the CCO calibration was performed. You should recalibrate CCO or CCI with transpulmonary C.O. measurements at least every 8 hours or when the hemodynamic condition of the patient has changed. The pressure measurement must be zeroed before a CCO calibration.
CCO/Tbl NoTransduc Numeric is replaced by -?- INOP tone	No transducer attached to the module or catheter disconnected.
SVR Chk Sources Numeric is replaced by -?- INOP tone	Not all measurements or values required to perform the calculation are available. Check the measurement sources.
SVR Chk Units Numeric is replaced by -?- INOP tone	The monitor has detected a conflict in the units used for this calculation. Check the unit settings.
SVR Set CVP Used Numeric is replaced by -?- INOP tone	No continuously measured CVP value is available. The monitor is using a preset CVP value for the calculation of SVR.
Tblood NoTransducer Numeric is replaced by -?- INOP tone	No transducer attached to the module or catheter disconnected.
Tblood Overrange Numeric is replaced by -?- INOP tone	Tblood out of range 17°C - 43°C.

Masimo rainbow SET INOPs

PVI INOPs

INOP Message, Indication	What to do
PVI Cannot Meas Numeric is replaced by -?- INOP tone	The PVI value is invalid/unavailable for an unexpected long period of time. Check the sensor placement. Try another adapter cable and sensor. If the INOP persists, contact your service personnel.
PVI Poor Signal Numeric is displayed with a small ?	The signal of the PVI measurement is poor and measurement accuracy may be compromised. If the INOP persists, consider changing the application site, or using another sensor.

SpCO INOPs

INOP Message, Indication	What to do
SpCO Cannot Meas Numeric is replaced by -?- INOP tone	The SpCO value is invalid/unavailable for an unexpected long period of time. Check the sensor placement. Try another adapter cable and sensor. If the INOP persists, contact your service personnel.
SpCO Low Perf Numeric is displayed with a small ?	The Perfusion Index is low and SpCO accuracy may be compromised. Stimulate the circulation at the sensor site. If the INOP persists, change the measurement site.
SpCO Poor Signal Numeric is displayed with a small ?	The signal of the SpCO measurement is poor and measurement accuracy may be compromised. If the INOP persists, consider changing the application site or using another sensor.

SpHb INOPs

INOP Message, Indication	What to do
<SpHb Label> Cannot Meas Numeric is replaced by -?- INOP tone	The SpHb value is invalid/unavailable for an unexpected long period of time. Check the sensor placement. Try another adapter cable and sensor. If the INOP persists, contact your service personnel.
<SpHb Label> Low Perf Numeric is displayed with a small ?	The Perfusion Index is low and SpHb accuracy may be compromised. Stimulate the circulation at the sensor site. If the INOP persists, change the measurement site.
<SpHb Label> Poor Signal Numeric is displayed with a small ?	The signal of the SpHb measurement is poor and measurement accuracy may be compromised. If the INOP persists, consider changing the application site or using another sensor.

SpMet INOPs

INOP Message, Indication	What to do
SpMet Cannot Meas Numeric is replaced by -?- INOP tone	The SpMet value is invalid/unavailable for an unexpected long period of time. Check the sensor placement. Try another adapter cable and sensor. If the INOP persists, contact your service personnel.

INOP Message, Indication	What to do
SpMet Low Perf Numeric is displayed with a small ?	The Perfusion Index is low and SpMet accuracy may be compromised. Stimulate the circulation at the sensor site. If INOP persists, change the measurement site.
SpMet Poor Signal Numeric is displayed with a small ?	The signal of the SpMet measurement is poor and measurement accuracy may be compromised. If the INOP persists, consider changing the application site, or using another sensor.

SpO2 INOPs

INOP Message, Indication	What to do
No 3D Desat Index INOP tone	The 3D Desat Index is "On", but currently no 3D Desat Index alarming is possible, wait until the values are recalculated.
No 3D Perf Delta INOP tone	The 3D Perf Delta is "On", but currently no 3D Perf Delta alarming is possible. Check the Perf settings and set the Perf Baseline.
<SpO₂ Label> : Only SpO₂ Numerics that are unavailable are replaced by -?- INOP tone	If issued, additional Masimo rainbow measurements are not available. Use a Masimo light shield to cover the sensor. Refer to the sensor's DFU for further details. To reinitialize rainbow parameters, remove and reapply the sensor.
<SpO₂ Label> ReplaceSensr Numeric is displayed with a small ?	If issued without a tone, the lifetime of the cable, sensor, or adhesive has expired, but you still have a grace period for monitoring. Replace the cable, sensor, or adhesive part before monitoring is no longer possible.
<SpO₂ Label> ReplaceSensr Numeric is replaced by -?- INOP tone	The lifetime of the connected cable, sensor, or adhesive has expired. No more monitoring is possible. Replace the cable, sensor, or adhesive sensor part.
<SpO₂ Label> Sensor Malf Numeric is replaced by -?- INOP tone	Make sure the adhesive part of the sensor is connected. If the INOP persists, try another adhesive sensor, or exchange the adhesive part. The cable, sensor, or adhesive sensor part type are unknown, or not supported by your software revision. Replace the cable, sensor, or adhesive sensor part using only Philips supported sensors listed in the section. The connected adhesive sensor part is defective.

SpOC INOPs

INOP Message, Indication	What to do
SpOC Cannot Meas Numeric is replaced by -?- INOP tone	The SpOC value is invalid/unavailable for an unexpected long period of time. Check the sensor placement. Try another adapter cable and sensor. If the INOP persists, contact your service personnel.
SpOC Low Perf Numeric is displayed with a small ?	The Perfusion Index is low and SpOC accuracy may be compromised. Stimulate the circulation at the sensor site. If the INOP persists, change the measurement site.
SpOC Poor Signal Numeric is displayed with a small ?	The signal of the SpOC measurement is poor and measurement accuracy may be compromised. If the INOP persists, consider changing the application site or using another sensor.

RRac INOPs

INOP Message, Indication	What to do
RRac Cannot Meas Numeric is replaced by -?- INOP tone	The RRac numerics are not displayed after the start-up phase. Check if the connected accessories are compatible for the RRac measurement. Check if the sensor is placed correctly.
RRac Chk Sensor Numeric is displayed with a small ?	RRac Monitoring is still possible but accuracy may be compromised. Check sensor, cable, and connections. If the INOP persists replace the sensor or the cable
RRac Chk Sensor Numeric is replaced by -?- INOP tone	No RRac monitoring is possible. Check sensor, cable, and connections. If the INOP persists replace the sensor or the cable.
RRac Extd.Update Numeric is displayed with a small ?	The RRac update period is extended due to bad signal conditions. Check the proper fit of the sensor, and reduce environmental noise level.
RRac Interference Numeric is displayed with a small ?	The signal of the RRac measurement is affected by interference or noise, and accuracy may be compromised. If the INOP persists, check if the sensor is placed correctly or use another sensor.
RRac Interference Numeric is replaced by -?- INOP tone	RRac cannot be derived, because of interference or noise. Check that the sensor is applied according to instructions. Try to reduce background noise, and check that nothing comes into contact with the sensor.
RRac No Sensor Numeric is replaced by -?- INOP tone	Make sure the cable and the sensor are connected. If the INOP persists, try another adapter cable and sensor. If you acknowledge this INOP, the RRac measurement will be switched off.
RRac No SpO₂ Numeric is replaced by -?- INOP tone	An SpO ₂ measurement has to be enabled for the RRac measurement to work. Connect an SpO ₂ sensor and enable an SpO ₂ measurement.
RRac Poor Signal Numeric is displayed with a small ?	The signal of the RRac measurement is poor and measurement accuracy may be compromised. If the INOP persists, check if the sensor is placed correctly. If INOP still persists, use another sensor.
RRac ReplaceSensr Numeric is displayed with a small ?	The lifetime of the connected sensor or cable has almost expired. Replace the sensor or cable before monitoring is no longer possible.
RRac ReplaceSensr Numeric is replaced by -?- INOP tone	The lifetime of the connected cable, sensor, or adhesive has expired. No more monitoring is possible. Replace the cable, sensor, or adhesive sensor part.
RRac Sensor Malf Numeric is replaced by -?- INOP tone	Defective sensor or cable. Replace the sensor or cable.
RRac Sensor Off Numeric is replaced by -?- INOP tone	The sensor is not properly applied to the patient. Apply the sensor following the instructions supplied by the manufacturer.
RRac Unkn.Sensor Numeric is replaced by -?- INOP tone	Incompatible or unrecognized sensor or cable. Replace the sensor or cable using only supported sensors listed in the section.

G7m Gas Analyzer INOPs

INOP Message, Indication	What to do
Agent Calculating	The gas analyzer is calculating the agent concentration. Wait until the calculation is finished.
<Agent Label> Change Scale	The wave of the agent shown is clipped (DES/ENF/HAL/SEV/ISO). Select a more appropriate wave scale to display the whole wave.
<Agent Label> Overrange INOP tone	The <AGT> value is higher than the measurement range. If you suspect a false high value, contact your service personnel.
Agent Mixture	Anesthetic agent mixture detected. There are three possible situations: The gas analyzer has detected more than two agents in the gas sample. The agent data is invalid, shown by -?- in place of the numerics. The gas analyzer has detected two agents in the gas sample. Both agents could be identified and the agent data is valid. In this case there is no INOP tone and the INOP message is for information only. The gas analyzer has detected two agents in the gas sample. There is a problem with the identification or the measurement accuracy. As measurement accuracy may be reduced, the numerics are displayed with a ? and an INOP tone will sound.
AGT Meas Malfunc Numerics replaced by -?- INOP tone	There is a problem with the agent measurement. Unplug the gas analyzer from the monitor and then plug it in again. If this INOP persists, contact your service personnel.
Align Watertrap	The water trap is not in the correct - vertical- position. Rotate the water trap to the vertical position.
awRR Overrange Numeric shown with ? INOP tone	The measured respiration rate is higher than the maximum measurable range.
Cal Running	Automatic internal calibration is running. Wait until the calibration is complete (INOP is cleared).
Check Watertrap INOP tone	Check whether the water trap is full; if so, drain or replace the water trap. Check that the sample line is not restricted. Check that the water trap is not disconnected.
CO₂ Change Scale	The CO ₂ wave is clipped. Select a more appropriate wave scale to display the whole wave.
CO₂ Overrange INOP tone	The CO ₂ value is higher than the measurement range. If you suspect a false high value, contact your service personnel.
CO₂ Unable To Meas Numeric is replaced by -?- INOP tone	The gas analyzer currently cannot measure CO ₂ . If this INOP persists, contact your service personnel.
<Gas Analyzer> Occlusion Numerics replaced by -?- INOP tone	Make sure that the sample line and exhaust line tubing is not kinked. Check the airway adapter for a build up of fluid. Empty the fluid and reposition the adapter if necessary. Ensure that the airway adapter port is facing upwards. Try replacing the sample line, water trap, or exhaust line. If this INOP persists, contact your service personnel.
<Gas Analyzer> Zero Failed Numerics shown with ?	A gas analyzer zero calibration failed. Check the exhaust tube for an occlusion or kinking and replace if necessary. If the zero has failed more than once, contact your service personnel. Note: The gas analyzer tries up to three zeros before the INOP appears.
GM Accuracy? Numerics shown with ?	Gas analyzer measurement accuracy may be reduced. Check that the gas inlet, water trap, and gas outlet tubing are not occluded. If this INOP persists, contact your service personnel.
GM Alarm Suppress	Gas analyzer alarms will be paused until breathing activity is first detected.
GM Component Malf	A gas analyzer component is not functioning. Some parameters may be unavailable or measured with reduced accuracy. Unplug the gas analyzer from the monitor and then plug it in again. If this INOP persists, contact your service personnel.

3 Patient Alarms and INOPs

INOP Message, Indication	What to do
GM Incompatible INOP tone	This version of the gas analyzer is not supported. Contact your service personnel.
GM Malfunction Numerics replaced by -?- INOP tone Gas Analyzer Setup LED may be blinking	There is a problem with the gas analyzer hardware. Unplug the gas analyzer from the monitor and then plug it in again, or switch the monitor off and then on again. If this INOP persists, contact your service personnel.
GM No Breath et and in numerics show the same value	No breath detected. Check tubing and patient connections.
GM Standby	The gas analyzer is in standby. To resume gas monitoring, select GM Exit Standby in the Setup GM menu, or press the "Standby" key on the gas analyzer module.
GM Switched Off INOP tone	The gas analyzer has switched off all possible internal components due to overheating. Allow the gas analyzer to cool down before resuming monitoring. If this INOP persists, contact your service personnel.
GM Unplugged	All gas measurements have been deactivated by unplugging the module. The measurements automatically disappear from the display. To switch the measurements on again, plug the module in again.
GM Warmup	The gas analyzer has not yet reached operating temperature and the measurement accuracy may be reduced.
GM Zero Running Numerics shown with ? INOP tone Second/third zero: numerics are unavailable	Automatic zero calibration in progress. If a Zero calibration fails, one or two additional Zero calibration attempts may be performed automatically. If the last Zero attempt fails, a <Gas Analyzer> Zero Failed INOP becomes active.
MAC Check Sources INOP tone may sound	Either not all measurements or values required to perform the calculation are available or some of the required values are questionable. Check the measurement sources and make sure they are all switched on and that none of them are invalid or questionable.
MAC Correction?	Enhanced MAC correction is on, but values for patient age and/or temperature are not available. Default values for age (40) and/or temperature (37°C/98.6 F) will be used.
N₂O Change Scale	The N ₂ O wave is clipped. Select a more appropriate wave scale to display the whole wave.
N₂O Overrange INOP tone	There is a problem with the N ₂ O measurement. If this INOP persists, contact your service personnel.
N₂O Unable To Meas Numeric replaced by -?- INOP tone	The gas analyzer currently cannot measure N ₂ O. If this INOP persists, contact your service personnel.
O₂ Change Scale	The O ₂ wave is clipped. Select a more appropriate wave scale to display the whole wave.
O₂ Overrange INOP tone	There is a problem with the O ₂ measurement. If this INOP persists, contact your service personnel.
O₂ Unable To Meas Numeric replaced by -?- INOP tone	The gas analyzer currently cannot measure O ₂ . If this INOP persists, contact your service personnel.
O₂ Zero Failed Numeric replaced by -?- INOP tone	An O ₂ zero calibration failed. Contact your service personnel.

EEG INOPs

INOP Message, Indication	What to do
EEG Equip Malf INOP tone	The EEG hardware is faulty. Contact your service personnel.
EEG Impedance High EEG1 ImpedanceHigh EEG2 ImpedanceHigh EEG3 ImpedanceHigh EEG4 ImpedanceHigh	The electrode impedance of electrodes in one or more channels exceeds the user-selected impedance limit. If only one channel is affected, the channel number is indicated. Check the impedance. If the impedance is too high, reconnect the electrodes according to the EEG monitoring setup guidelines. If the INOP persists, contact your service personnel.
EEG Leads Off EEG1 Leads Off EEG2 Leads Off EEG3 Leads Off EEG4 Leads Off	Two or more electrodes are not connected. Check in the EEG Impedance / Montage window which electrodes are affected and reconnect the electrodes.
EEG Line Noise EEG1 Line Noise EEG2 Line Noise EEG3 Line Noise EEG4 Line Noise	Excessive line noise has been detected in one or more EEG channels. Keep all cables together and away from metallic bodies, other cables & radiated fields.
EEG Muscle Noise EEG1 Muscle Noise EEG2 Muscle Noise EEG3 Muscle Noise EEG4 Muscle Noise	Too much power above 30 Hz has been detected in one or more EEG channels. Check the Electrode-to-Skin Impedance and reposition the electrode away from possible muscle activity, if necessary.
EEG NoTransducer INOP tone	The trunk cable is disconnected from the EEG plug-in module. Reconnect the trunk cable. Acknowledging this INOP switches the measurement off.
EEG Overrange EEG1 Overrange EEG2 Overrange EEG3 Overrange EEG4 Overrange	Input signal is too high in one or more channels. This is usually caused by interfering signals such as line noise or electrosurgery.
EEG Unplugged INOP tone	Plug in the module. Acknowledging this INOP switches off the measurement.
EEG1 Lead Off <n> EEG2 Lead Off <n> EEG3 Lead Off <n> EEG4 Lead Off <n> [n = electrode]	Reconnect specified electrode.
EEG1 Lead Off EEG2 Lead Off EEG3 Lead Off EEG4 Lead Off at Information Center	One or more electrodes are not connected. Check in the EEG Impedance / Montage window on the monitor which electrode(s) are affected and reconnect the electrodes.

BIS INOPs

INOP Message, Indication	What to do
BIS Cable Usage INOP tone	The semi-reusable sensor cable has exceeded the maximum number of uses. Replace the cable.
BIS Device Disconn INOP tone	The BIS device is not connected to the BIS module or the BIS interface board. Acknowledging this INOP switches the measurement off.
BIS Device Incomp INOP tone	The BIS device software is not compatible with the BIS module or with the monitor software. A software upgrade may be required. Contact your service personnel.
BIS Device Malfunc INOP tone	The BIS device is faulty. Disconnect and reconnect it to the module or BIS interface board. If the INOP persists, replace the BIS device. For monitors using the interface board - Malfunction on interface board. If the INOP persists, contact your service personnel.
BIS DSC Disconnect INOP tone	DSC is not properly connected OR either DSC or BIS engine may be faulty. Make sure that the DSC is properly connected to the BIS Engine. If INOP persists, replace DSC with a known good one of the same type. If INOP persists replace BIS engine. Acknowledging this INOP switches the measurement off.
BIS DSC Incomp INOP tone	DSC is not supported by the BIS engine or new DSC connected to an old BIS engine. A software upgrade may be required. Contact your service personnel.
BIS DSC Malfunc	Electrocautery used during self-test OR malfunction in the DSC hardware. Make sure not to use electrocautery during the self-test procedure. Disconnect and reconnect the DSC to the BIS engine. If the INOP persists, replace the DSC or contact your service personnel.
BIS DSC Upgrade INOP tone	DSC update currently being carried out. This INOP will disappear when the DSC update is finished. Do not disconnect the DSC during the update. No action is needed.
BIS Electr. Disc. INOP tone	One or more electrodes are not connected to the semi-reusable sensor cable. Check all electrode connections.
BIS Engine Disconn INOP tone	BIS engine not connected OR Module Cable defective. Make sure that the Module Cable is properly connected. If INOP persists, replace the Module Cable. Acknowledging this INOP switches the measurement off.
BIS Engine Incomp INOP tone	BIS engine software is not supported. A software upgrade may be required. Contact your service personnel. For monitors using the interface board - BIS engine not supported.
BIS Engine Malfunc INOP tone	Malfunction in the BIS engine hardware. Disconnect and reconnect the BIS engine. If the INOP persists, replace BIS engine.
BIS Equip Malf INOP tone	There is a malfunction in the BIS hardware. Unplug and replug the BIS module. If the INOP persists, contact your service personnel.
BIS High Impedance INOP tone may sound	Impedance of one or more electrode(s) is above the valid range, most often caused by bad skin preparation. Check the sensor montage and press the electrode pads firmly. If this INOP persists, replace the sensor(s) in question using correct skin preparation. If INOP persists, contact your service personnel.
BIS IsoelectricEEG	No discernible EEG activity is detected for longer than one minute. Check the patient. Check that the electrodes are properly connected.
BIS Lead Off INOP tone may sound	One or more electrodes have no skin contact and therefore impedances cannot be measured. Check the sensor montage and press the electrode pads firmly. If this INOP persists, replace the sensor(s) in question, using correct skin preparation.
BIS Power Off INOP tone	Unplug and replug the BIS module or, for the MP20/MP30, disconnect and reconnect the BISx from the Interface board. If the INOP persists, contact your service personnel.

INOP Message, Indication	What to do
BIS Sensor Check INOP tone may sound	The Cyclic Impedance check is running. It will stop automatically if all impedances are within the valid range. If any electrodes do not pass the impedance test, check the sensor montage and press the electrode pads firmly. To manually stop the Cyclic Impedance Check, select Sensor Check off in the Setup BIS menu.
BIS Sensor Disconn INOP tone	The sensor is not properly connected to the patient interface cable (PIC) and/or the PIC is not properly connected to the DSC or BISx, or the sensor or PIC or DSC or BISx may be faulty. Check all the connections. Disconnect and reconnect the sensor, PIC, DSC, BISx. If the INOP persists, replace the sensor. If the INOP persists, replace PIC. If INOP persists, contact your service personnel. Acknowledging this INOP switches the measurement off.
BIS Sensor Incomp INOP tone	Unsupported sensor connected or sensor type unknown or not supported by your software revision. Replace the sensor, using only Philips supported sensors.
BIS Sensor Malfunc INOP tone	Malfunction in the sensor hardware, most often caused by liquids permeating into the connectors OR patient interface cable (PIC) or DSC or BISx may be faulty. Replace the sensor. Manually initiate a Cyclic Impedance Check. Make sure all electrodes pass the test. Make sure that the both sides of the PIC connector (between PIC and sensor) are dry. If you are not sure that the connector is dry, replace the PIC until it has dried. If this INOP persists, contact your service personnel.
BIS Sensor Usage INOP tone	Excessive sensor usage. Replace sensor. A Cyclic Impedance Check will start automatically.
BIS SQI < 15% INOP tone	If the signal quality is below 15%, no BIS numerics can be derived. This may occur as a result of artifacts such as those generated from motion or the presence of electrocautery devices. Make sure the sensor is properly attached to the patient. Manually initiate a Cyclic Impedance Check. Make sure all electrodes pass the test. Make sure the patient is completely relaxed (even small motions of the facial muscles affect the signal quality).
BIS Unplugged INOP tone	Plug in the BIS module. Acknowledging this INOP switches off the measurement.

NMT INOPs

INOP Message, Indication	Explanation
NMT Alarm Suppress	NMT alarms are suppressed until the TOF count reaches zero for the first time.
NMT Cable Disconn INOP tone	No patient cable is connected to the NMT measurement module. Acknowledging this INOP switches the NMT measurement off.
NMT Cable Unknown INOP tone	The patient cable connected to the NMT module is not supported or cannot be identified. Replace it with a supported cable.
NMT Cal Failed	The NMT calibration cycle failed. Check that the sensor and the electrodes are placed properly, then start another calibration. Ensure that patient's arm is kept still before and during the calibration cycle. If calibration fails again, replace the patient cable. If INOP persists, contact your service personnel.
NMT Cal Running	An NMT calibration is running. Wait until the calibration is complete.
NMT Cannot Measure INOP tone	NMT is unable to reliably derive measurement values. Check that the sensor and the electrodes are placed properly and start another measurement. If this INOP persists, try another patient cable.
NMT Equip Malfunc INOP tone	There is a problem with the NMT hardware. Unplug the NMT measurement module then plug it in again. If the INOP persists contact your service personnel.
NMT Impedance High	The impedance of the NMT stimulation electrodes has exceeded the allowed limit. Check that the electrodes are placed properly, have firm skin contact and have not dried out.
NMT Incompatible INOP tone	This version of the NMT measurement module is not supported, or the module firmware is incomplete and needs to be upgraded. Contact your service personnel.

3 Patient Alarms and INOPs

INOP Message, Indication	Explanation
NMT Lead Off INOP tone	One or both NMT stimulation electrodes have become detached from the patient. Check that both electrodes have firm skin contact, that the electrodes are placed properly and that the lead wires are connected.
NMT Neo Patient? INOP tone	The NMT measurement does not support neonatal patients. Check the patient category.
NMT Noisy Signal INOP tone	The NMT signal is too noisy to derive measurement values reliably. If electrosurgery is currently being used, repeat the NMT measurement after it has stopped.
NMT Overcurrent INOP tone	The current through the NMT stimulation electrodes is too high. Check that the patient cable is not visibly damaged. Disconnect and reconnect the patient cable. If this INOP persists, replace the cable and/or module.
NMT Overrange	The signal from the acceleration sensor is out of the measurement range. Check that the acceleration sensor is positioned properly. If this INOP persists, try another patient cable.
NMT Sensor Malfunc INOP tone	There is a problem with the acceleration sensor of the NMT patient cable. Disconnect and reconnect the patient cable. If this INOP persists, replace the cable.
NMT Unplugged INOP tone	Plug in the NMT Module. Acknowledging this INOP switches off the measurement
NMT Upgrade INOP tone	An NMT module firmware upgrade is in progress. NMT monitoring is currently not possible. Wait until the upgrade has completed and this INOP is no longer displayed. Do not unplug the module or switch off power.

IntelliBridge INOPs

INOP Message, Indication	What to do
Device Check Setup INOP tone	Device identification completed, but communication could not be established due to timeout. IntelliBridge INOP abbreviations may differ slightly depending on the device category.
Device Chk Config INOP tone	Device identification completed, but communication could not be established due to error. IntelliBridge INOP abbreviations may differ slightly depending on the device category.
Device Demo Data INOP tone	The device connected to the IntelliBridge module reports demo data but the monitor is not in DEMO mode.
Device Real Data INOP tone	The monitor is in DEMO mode but the device connected to the IntelliBridge module reports data that are not flagged as demo data.
Device Unsupported INOP tone	Device identification completed, but no appropriate device driver installed. IntelliBridge INOP abbreviations may differ slightly depending on the device category.
<EC10 / EC40> Equip Malf INOP tone	Malfunction in the IntelliBridge module. If this message appears repeatedly, the module must be replaced. Contact your service personnel.
EC10 INOP !! EC10 INOP !!! EC10 INOP at Information Center	A technical alarm is present on the IntelliBridge EC10 module. On the monitor the indication is a red (!!!), yellow (!!) or cyan alarm lamp (as appropriate), an INOP tone and an INOP text that is defined by the IntelliBridge EC10 device driver.
<ExternalDevice>Unplugged INOP tone	The IntelliBridge module has been unplugged from the rack, or the whole rack has been disconnected. Acknowledging this INOP switches off the measurement. IntelliBridge INOP abbreviations may differ slightly depending on the device category.
No Device Data	Communication with a connected device has been lost.
Text Upload Failed INOP tone	Incoming text from the IntelliBridge modules exceeds the maximum limit. Try unplugging one of the IntelliBridge modules. If the INOP occurs repeatedly contact your service personnel; a software upgrade may be necessary.

Telemetry INOPs

INOP Message, Indication	What to do
Check ECG Settings INOP tone	Synchronization of ECG settings between the monitor and Information Center has failed. Check that the ECG settings in use are appropriate.
!! Check ECG Source	Both the telemetry device and the monitor have valid ECG signals
Chk SpO₂T Settings INOP tone	Synchronization of SpO ₂ T settings between the monitor and Information Center has failed. Check that the SpO ₂ T settings in use are appropriate.
Invalid Leadset	The leadset plugged in cannot be used with the telemetry device.
Leadset Unplugged	The leadset has been unplugged from the telemetry device.
No ECG Source	A telemetry device is paired with the monitor but the Information Center is not detecting a valid ECG signal from either of them.
!! Repl. Tele Batt !!! Repl. Tele Batt Severe yellow/red INOP tone During this INOP, alarms cannot be paused or switched off.	The battery in the telemetry device is almost empty and must be replaced.
Tele Battery Low	The battery in the Telemetry device is low and must be replaced soon.
!! Tele Disconnect !!! Tele Disconnect Severe yellow/red INOP tone	Telemetry transceiver was disconnected or short range radio link was lost. For cable connections; check Telemetry interface, cable connection and setup. For short range radio connections: if the telemetry transceiver has not moved out-of-range, check for interference sources close to the monitor (bluetooth devices, DECT phones, cellular phones, microwaves, etc.). If this INOP persists, ask your service personnel to survey the interference sources.
Tele INOP !! Tele INOP !!! Tele INOP Severe yellow/red INOP tone	A telemetry device assigned to the patient is in an INOP condition. Check the detailed INOP information at the Information Center and resolve the INOP condition(s) at the telemetry device.
Tele Sync Unsupp. INOP tone	The Multi-Measurement Module in use does not support synchronization of ECG and SpO ₂ settings between the monitor and central station after a telemetry device has been paired. Use a Multi-Measurement Module with revision E.0 or above.

ProtocolWatch INOPs

INOP Message, Indication	What to do
PW: Check Settings	Contact your service personnel. Settings could not be loaded or interpreted correctly.
PW: In Conflict	There is a patient information mismatch which has not yet been resolved (>15 minutes).
PW:Action Required	The protocol currently running requires a user response. Check which pop-up window is displayed and provide the appropriate response.

Calculated Values INOPs

INOP Message, Indication	What to do
ΔSpO₂ Chk Sources Numeric is replaced by -?-	Not all measurements or values required to perform the calculation are available. Check measurement sources.
ΔSpO₂ Chk Units Numeric is replaced by -?-	The monitor has detected a conflict in the units used for this calculation. Check the unit settings.

3 Patient Alarms and INOPs

INOP Message, Indication	What to do
Sp-vO₂ Chk Sources Numeric is replaced by -?-	Not all measurements or values required to perform the calculation are available. Check measurement sources.
Sp-vO₂ Chk Units Numeric is replaced by -?-	The monitor has detected a conflict in the units used for this calculation. Check the unit settings.
SVR Chk Sources Numeric is replaced by -?-	Not all measurements or values required to perform the calculation are available. Check measurement sources.
SVR Chk Units Numeric is replaced by -?-	The monitor has detected a conflict in the units used for this calculation. Check the unit settings.
SVR Set CVP Used	A CVP value is required for this calculation, but is not currently being measured. The monitor is using the CVP value preset in the Setup SVR menu.
SVRI Chk Sources	Not all measurements or values required to perform the calculation are available. Check measurement sources.
SVRI Chk Units	The monitor has detected a conflict in the units used for this calculation. Check the unit settings.
SVRI Set CVP Used	A CVP value is required for this calculation, but is not currently being measured. The monitor is using the CVP value preset in the Setup SVR menu.
ΔTemp Chk Sources Numeric is replaced by -?-	Not all measurements or values required to perform the calculation are available. Check measurement sources.
ΔTemp Chk Units Numeric is replaced by -?-	The monitor has detected a conflict in the units used for this calculation. Check the unit settings.

Cableless Measurement Device INOPs

INOP Message, Indication	What to do
cl NBP Batt Empty !! cl NBP Batt Empty !!! cl NBP Batt Empty Corresponding INOP tone	The remaining battery time of the NBP Pod is below 30 minutes. Charge the battery.
cl NBP Batt Incomp INOP tone	The battery in use with the NBP Pod is incompatible. Replace it with one approved for use with the NBP Pod.
cl NBP Batt Low INOP tone	The remaining battery time of the NBP Pod is below 2 hours.
cl NBP Batt Malf INOP tone	There is a malfunction in the NBP Pod's battery system. Contact your service personnel.
cl NBP Batt Temp INOP tone	The temperature of the battery in the NBP Pod is critically high. Check that the Pod is not covered or exposed to a heat source. If the INOP persists, remove the Pod from the patient and contact your service personnel.
cl NBP Check Batt INOP tone	The battery in the NBP Pod is nearing the end of its useful life. Only 50 charge/discharge cycles remain. Contact your service personnel to replace the battery.
cl NBP Chk Chrg IF	The interface between the NBP Pod and the Charging Station is not working properly. Try cleaning the contacts and reposition the Pod on the charging station.
cl NBP ChkSettings	The NBP Pod's settings may have changed or become corrupt. Check the settings.
cl NBP Disconnect INOP tone	The NBP Pod has lost the connection to the monitor.
cl NBP License Req	The NBP Pod requires a valid software license for operating.
cl NBP No Cradle INOP tone	The NBP Pod is not in its cradle.

INOP Message, Indication	What to do
cl NBP Remove INOP tone	The temperature of the battery in the NBP Pod is too high. Remove the Cableless Measurement Device from the patient and contact service personnel.
cl NBP Serv Batt INOP tone	The battery in the NBP Pod has reached the end of its useful life. It can no longer be charged. Contact your service personnel to replace the battery.
cl SpO₂ Batt Empty !! cl SpO₂ BatEmpty !!! cl SpO₂ BtEmpty Corresponding INOP tone	The remaining battery time of the SpO ₂ Pod is below 30 minutes. Charge the battery.
cl SpO₂ Batt Incmp INOP tone	The battery in use with the SpO ₂ Pod is incompatible. Replace it with one approved for use with the SpO ₂ Pod.
cl SpO₂ Batt Low INOP tone	The remaining battery time of the SpO ₂ Pod is below 2 hours.
cl SpO₂ Batt Malf INOP tone	There is a malfunction in the SpO ₂ Pod's battery system. Contact your service personnel.
cl SpO₂ Batt Temp INOP tone	The temperature of the battery in the SpO ₂ Pod is critically high. Check that the Pod is not covered or exposed to a heat source. If the INOP persists, remove the Pod from the patient and contact your service personnel.
cl SpO₂ Check Batt INOP tone	The battery in the SpO ₂ Pod is nearing the end of its useful life. Only 50 charge/discharge cycles remain. Contact your service personnel to replace the battery.
cl SpO₂ Chk ChrgIF	The interface between the SpO ₂ Pod and the Charging Station is not working properly. Try cleaning the contacts and reposition the Pod on the charging station.
cl SpO₂ Chk Sett	The SpO ₂ Pod's settings may have changed or become corrupt. Check the settings.
cl SpO₂ Disconnect INOP tone	The SpO ₂ Pod has lost the connection to the monitor.
cl SpO₂ No Cradle INOP tone	The SpO ₂ Pod is not in its cradle.
cl SpO₂ Remove INOP tone	The temperature of the battery in the SpO ₂ Pod is too high. Remove the SpO ₂ Pod from the patient and contact service personnel.
cl SpO₂ Serv Batt INOP tone	The battery in the SpO ₂ Pod has reached the end of its useful life. It can no longer be charged. Contact your service personnel to replace the battery.
clSpO₂ License Req	The SpO ₂ Pod requires a valid software license for operating.

Managing Patients and Equipment

When the monitor is used together with an Information Center, a variety of services are provided to manage the interconnections between patients, equipment, hospital beds, caregivers, and so on.

Many services can be used both at the monitor and at the Information Center, resulting in a more efficient workflow.

Which services are available will depend on which Information Center you have. The **Philips Patient Information Center iX (PIC iX)** provides more services and functionality than the **Philips IntelliVue Information Center (PIIC)**. In these Instructions for Use, information that is only valid for one of the Information Centers will be marked with a corresponding side heading, for example:

PIC iX For a list of the differences between the two Information Centers, see [“Information Center Compatibility” on page 146](#).

Patient Concepts

For a patient to be part of the system their identification data must be entered into the system. A patient can then be assigned to a bed, have equipment assigned directly to him, and have a location set when he is not currently in the bed.

Equipment Concepts

Depending on how equipment is used in your facility, there are various ways to associate devices with patients, beds or monitors. Equipment usage must be configured appropriately at the Information Center and the monitoring equipment.

PIC iX By configuration, equipment can be assigned:

- permanently to a bed,
- on demand to a bed or host monitor, or
- directly to a patient.

The foundation for a particular equipment use model is laid in the configuration settings in the monitor and the Information Center. Refer to the corresponding configuration guides for further details.

Additionally there are mechanisms to automatically free up equipment that is no longer used. This prevents unnecessary patient mismatches when the equipment is used for the next patient and avoids data of different patients getting mixed.

PIC iX When connected to PIC iX, equipment states are tracked by the system. When the equipment is not assigned to a patient or no patient is admitted at a monitor, the equipment is considered as free equipment in the system. Equipment that is assigned or has a patient admitted is tracked as used (i.e. not free) equipment.

The Information Center uses the equipment state (free/not free) to maintain and support workflow and equipment lists.

Bed Management with a Hospital Information System

(Not available with PIIC iX Release B and earlier)

Depending on your setup, the PIC iX may receive patient identification and bed assignment information from a hospital information system (HIS). This information triggers an action at the monitor (admission, discharge, or transfer), that requires your confirmation.

This situation is indicated at the monitor with a symbol next to the patient name.



Admission pending



Discharge pending



Transfer pending

Additionally, a window pops up on the monitor asking you to confirm the action proposed by the HIS.

In the confirmation window, the proposed action is stated, for example, **Admit <Patient ID> to <Bed>..** You have two options:

- You can confirm that the action be completed.

In the example above, the patient is then admitted to the bed. The HIS symbol is no longer displayed and all equipment conflicts are resolved. The data on the monitor, the Information Center and the HIS are in agreement.

- You can delay the confirmation.

In the example above, the patient is then not admitted at the monitor. The HIS symbol continues to be displayed next to the patient name.

If the bed is not available for the patient proposed by the HIS, the data at the HIS must be corrected. After this correction, the HIS symbol is no longer displayed.

If the confirmation window is not open, you can open it by selecting the HIS symbol.

Managing Patients

In order to attribute collected measurement data to a specific patient, or assign equipment or a bed to a specific patient, each patient in the system must be identified. By admitting a patient, you identify them for the system.

When equipment is freed up (for example by discharging the patient, removing a monitor from a patient or using End Case) the collection of data is officially ended for this patient and important settings on the monitor are reset to the defaults.

WARNING

Always perform a discharge or free up the monitor before starting monitoring for a new patient, even if your previous patient was not admitted. Failure to do so can lead to data being attributed to the wrong patient.

Admitting a Patient

The monitor displays physiological data and stores it in the trends as soon as a patient is connected. This lets you monitor a patient who is not yet admitted. It is however important to admit patients properly so that you can identify your patient on recordings, reports, and networked devices.

During admission you enter data that the monitor needs for safe and accurate operation. For example, the patient category setting determines the algorithm the monitor uses to process and calculate some measurements, the safety limits that apply for some measurements, and the alarm limit ranges.

If admission data has been provided from a hospital information system, you will not be able to manually enter admission data at the monitor, or to edit the data provided.

NOTE

It is strongly recommended that the same patient data fields be configured to be mandatory at the monitor and the Information Center.

To admit a patient:

- 1 Select the patient name field or select the **Patient Demogr.** SmartKey to open the **Patient Demographics** window.
- 2 Select **Admit Patient**.
The **Enter Patient Demographics** window appears. You can enter data as normal, using the keyboard or a barcode scanner, or, with **PIC iX**, use the **Find Patient** key to search for patient data in connected systems as described in “Using "Find Patient" to Search for Patient Data” on page 122.
- 3 Enter the patient information: select each field and use the keyboard or barcode scanner or choose from the pop-up list of alternatives to input information.
When you enter data, the Information Center will automatically check for corresponding data and will suggest an appropriate action based on what it finds. You can select **Confirm** to accept the suggestion or **Cancel** to reject it.
 - **Last Name:** Enter the patient's last name (family name).
 - **First Name:** Enter the patient's first name.
 - **Middle Name** (if configured to appear): Enter the patient's middle name.
 - **Lifetime ID, Encounter ID:** Whether these fields appear and how they are labeled can be configured for your hospital. One or both fields may be displayed and the labels may read: **MRN, Case ID, Visit Number**, or other alternatives. Enter the appropriate data for the fields displayed.
 - **Patient Cat.:** Choose the patient category, either **Adult, Pedi**, or **Neo**.
 - **Paced Mode:** Choose **On** or **Off** (You must use **On** if your patient has a pacemaker). With **PIC iX** there is a third choice: **Unconfirmed**. When the paced mode is **Unconfirmed**, the algorithm for paced patients will be used.
 - **Height:** Enter the patient's height.
 - **Weight:** Enter the patient's weight.
 - **BSA:** The monitor calculates the body surface area automatically.
 - **Date of Birth:** Enter the patient's date of birth, in the form dd/mmm/yyyy.
 - **Age:** The monitor calculates the patient age automatically.
 - **Gender:** Choose **Male** or **Female**.
 - **Notes (1) / Notes (2):** Enter any extra information about the patient or treatment.

When admission is complete, the patient's name appears on the monitor info line at the top of the screen together with the symbol indicating the patient category. By clicking on this section of the information line, also when no patient is admitted, you can open the **Patient Demographics** window at any time. There you can change patient data or set patient category and paced mode as described above.

Beginning Monitoring

If the monitor already has a patient admitted, or has been used for another patient without admission, select the **New Patient** key to safely begin monitoring of the new patient.

When you select **New Patient**, the monitor is freed. All settings are reset to the defaults, all patient data and trend data are deleted, and monitoring at the Information Center may stop for monitors designated as transport monitors. Depending on your equipment configuration, selecting **New Patient** may transfer the currently admitted patient out of the bed. A message will appear requiring your confirmation of these actions.

After selecting **New Patient**, you can admit your patient as described in “[Admitting a Patient](#)” below.

Using "Find Patient" to Search for Patient Data

PIC iX You can use the **Find Patient** key to search for patient data in the Information Center and any connected hospital information systems. The search will look for currently admitted or previously admitted patients matching the search data you enter.

To search for patient data:

- 1 Select the **Find Patient** key.
A window opens with an on-screen keyboard.
- 2 Type in the last name or an ID, or a part of it, and select **Enter** on the keyboard.
The search results will be displayed in a **Select Patient** window. The system provides a list of all matching patients.
- 3 Highlight the patient you want to admit to this bed.
- 4 Depending on their current status, you will be asked whether you want to readmit them, or transfer them to this bed.
- 5 Select **Confirm** to complete the admission or transfer.

Patient Category and Paced Mode

The patient category setting determines the algorithm the monitor uses to process and calculate some measurements, the safety limits that apply for some measurements, and the alarm limit ranges.

The paced mode setting determines whether the monitor shows pacemaker pulses or not. When **Paced Mode** is set to **Off**, pace pulses are filtered and therefore do not show in the ECG wave.

WARNING

Patient Cat. and **Paced Mode** will always contain a value, regardless of whether the patient is fully admitted or not. If you do not specify settings for these fields, the monitor uses the default settings from the current profile, which might not be correct for your patient.

Patient category

Changing the patient category may change the arrhythmia and NBP alarm limits. If possible, always load a suitable profile after changing patient category, and always check alarm limits to make sure that they are appropriate for your patient.

Paced mode

For paced patients, you must set **Paced Mode** to **On**. If it is incorrectly set to **Off**, the monitor could mistake a pace pulse for a QRS and fail to alarm during asystole. With PIC iX, the paced mode may be **Unconfirmed** which will assume a pacemaker is present. You should still set the **Paced Mode** to **On** for paced patients to make the status clear.

Admitting a Centrally-Monitored Patient

You can admit a patient at either the bedside or the Information Center. When you admit a patient, the patient's name appears on the bedside monitor and the Information Center.

If you do not fill in all patient information required by the Information Center, the Information Center may reject the admission. Complete all the required fields and try again to admit the patient.

Starting Central Monitoring from the Bedside

(Not available with PIIC iX Release B and earlier)

Admitting a Patient and Starting Central Monitoring

Before starting, check that the monitor is not assigned to a patient or bed. If it is, first remove the monitor from the patient or bed. See [“Removing Equipment” on page 135](#).

- 1 Select the **Select Bed** SmartKey, if configured. If not, open the **Equipment** window, select the Information Center area, then **Select Bed**.
- 2 If a unit list appears, select the correct unit.
- 3 Select the correct bed from the list shown.
- 4 Select the **Confirm** pop-up key.
- 5 Wait until the bed label is displayed at the top of the screen.
- 6 Confirm by selecting **Yes**. This ensures that any data from a previous patient is cleared.
- 7 Select the **Quick Admit** SmartKey.
- 8 Enter the required data (ID fields or last name depending on configuration) with the keyboard or a barcode scanner.
- 9 Select **Enter**.
- 10 Select the **Confirm** pop-up key, if it appears (configuration-dependent).

Adding the Monitor to a Centrally Monitored Bed

- 1 Admit the patient to the monitor (see [“Beginning Monitoring” on page 121](#)).
If the patient is admitted at the Information Center and the bed is assigned to a sector, a window will appear asking you to confirm that the monitor be assigned to the bed.
- 2 Select the **Confirm** pop-up key.

Quick Admitting a Patient

Use Quick Admit to quickly admit a patient using only a limited set of demographic data.

- 1 Select the **Quick Admit** SmartKey.
- 2 Enter the required data (ID fields or last name depending on configuration) with the keyboard or a barcode scanner.
- 3 Select **Enter**.
- 4 In the confirmation window, select **Confirm** to stop monitoring for the previous patient or free up the monitor (if confirmation is configured).
- 5 Check that patient category and paced status are correct for the new patient.
- 6 Check the current profile and, if necessary, load an appropriate profile.

If the monitor is connected to an Information Center and only the ID field is entered, the patient name may be set to - - - at the Information Center, depending on the configuration. Complete the rest of the demographic details as soon as possible to fully identify the patient on the network, on the monitor and on printed reports. To complete the details, open the **Patient Demographics** window and complete all required fields.

Using Stat Admit

Stat Admit allows you to admit a patient with a temporary patient identification. It can be used in cases when the patient ID is unknown or when the data is not yet available.

The Stat Admit function generates content for a name or ID field using the current date and time. A random lower case letter is added at the end to reduce the chance of creating the same name or ID simultaneously at two monitors. So a name field would be filled with, for example:

19:32:45-30MAR15a

Depending on your configuration, a name field, an ID field, or all fields defined as mandatory will be filled. The exact format of the date and time data depends on the size of the field being filled and the language of the monitor user interface.

Additionally, if configured, Stat Admit can enter the current bed label or equipment label as a record of the location at admission time.

Admitting with Stat Admit

If Stat Admit is available for use, one of the following two methods will be set up:

- Using the SmartKey - select the **Stat Admit** SmartKey.
- Using a barcode or RFID label - read the special Stat Admit code.

Depending on your configuration, either the temporary ID will appear directly on the monitoring screen or the **Enter Patient Demographics** window will open for you to confirm the temporary ID.

Editing Patient Information

To edit the patient information after a patient has been admitted, select the patient name field on the Main Screen to open the **Patient Demographics** window, and make the required changes.

PIC IX If data has been provided by a hospital information system, you will not be able to edit it on the monitor.

Ending Monitoring for a Patient

There are several ways to end monitoring for a patient, depending on whether there is an Information Center connection, and on the configuration of the Information Center and the monitor. Discharging a patient and removing the monitor from a patient are described here. You can also end monitoring by admitting a new patient, as described in [“Beginning Monitoring” on page 121](#).

Depending on your configuration, monitoring for a patient may end automatically when the monitor has been powered off or in standby mode for a set time, or when no basic measurements have been made for a set time.

WARNING

Always end monitoring for the previous patient (with **Discharge Patient**, **Remove Monitor**, **End Case** or **New Patient**) before starting monitoring for a new patient, even if your previous patient was not admitted. Failure to do so can lead to data being attributed to the wrong patient.

Discharging a Patient

The discharge function is only available when the patient is monitored centrally at an Information Center. A discharge transfers the patient out of the bed and frees all devices used for the patient. The discharge function may be disabled at a monitor designated as a transport monitor, to ensure that a patient cannot be accidentally discharged from the system when the transport monitor is used for another patient.

A discharge:

- clears the patient demographics
- erases all patient measurement data (such as trend, event, and calculation data) from the monitor, measurement modules and Information Center. This ensures that data from a previous patient are not mixed with data from a new patient.
- resets patient category and paced settings to the settings defined in the default Profile
- resets all monitor and measurement settings as well as the active Screen to the settings defined in the default Profile
- discharges the patient from the Information Center.

Make sure that you have printed out any required reports before discharging. Check that a functioning local or central printer is available before you use **End Case**.

To Discharge a Patient

- 1 Select the patient name field or select the **Patient Demogr.** SmartKey to open the **Patient Demographics** window and associated pop-up keys.
- 2 Select the pop-up key for either:
 - **End Case** - to print any configured end case reports or vital signs recording, discharge the patient and clear the patient database, then enter standby mode. If an **End Case** SmartKey is configured for your monitor, you can also select this instead and then confirm.
To see which end case reports are set up for your monitor, select **Main Setup, Reports**, then **Auto Reports**. For each auto report, if **End Case Report** is set to **On**, this report will be printed when you select **End Case**. See [“Setting Up Auto Reports” on page 402](#) for information on setting up end case reports.
 - **Dischrg Patient** - to discharge the patient without printing any reports.

Removing the Monitor

Removing a monitor stops using the monitor for the current patient and frees up the monitor and all devices assigned to that monitor.

Removing the monitor:

- clears the patient demographics in the monitor.
- erases all patient measurement data (such as trend, event, and calculation data) from the monitor and devices assigned to the monitor. This ensures that data from a previous patient are not mixed with data from a new patient.
- resets patient category and paced settings to the settings defined in the default Profile.
- resets all monitor and measurement settings as well as the active Screen to the settings defined in the default Profile.

If the monitor is locked to the bed and is connected to an Information Center, the remove function is not available and you will have to discharge the patient.

To Remove a Monitor

- 1 Open the **Equipment** window - either directly in **Main Setup** or by selecting the bed label in the information line.
- 2 Select the monitor.
- 3 Select the **Remove Monitor** pop-up key.

New Patient Check

The monitor can be configured to ask you whether a new patient is now being monitored in certain situations:

- after a specified power-off period
- after a specified standby period
- when no basic vitals (HR, RR, Pulse, SpO₂, NBP) have been measured for a specified period

The pop-up window is entitled **Is this a New Patient?**. The monitor offers a **Yes** key to stop monitoring for the previous patient and begin monitoring a new patient and a **No** key to continue monitoring with the current patient data and settings.

The time periods for the three conditions can be configured independently.

Transferring Patients

To save you from having to enter the same patient data multiple times and enable patient transfer without loss of data, information can be shared between Multi-Measurement Modules, patient monitors, and Information Centers.

- patient demographic information is shared between connected Multi-Measurement Modules, patient monitors, and Information Centers
- measurement settings and calibration data can be uploaded from a Multi-Measurement Module to a patient monitor, if configured
- trend information can be uploaded from a Multi-Measurement Module to a patient monitor, if configured.

Different sets of patient and measurement-related data are stored in the monitor and the Multi-Measurement Module. Understanding this will help you to understand what happens to patient data when you transfer patients.

Patient Information	Stored in Monitor	Stored in X1 MMS, MMX and extensions	Stored in X2/X3 and extensions
Patient demographics (name, DOB, patient IDs)	yes	yes	yes
Monitor settings (alarm pause time, alarm volume)	yes	no	no
Measurement settings for all measurements (alarm limits, measurement on/off, etc.)	yes	yes, for all Multi-Measurement Module and Measurement Extension measurements	yes, for all Multi-Measurement Module and Measurement Extension measurements

Patient Information	Stored in Monitor	Stored in X1 MMS, MMX and extensions	Stored in X2/X3 and extensions
Trend data	yes, for all Multi-Measurement Module, Measurement Extension and measurement module measurements (up to a maximum of 24 or 32 or 50 or 100, depending on your database configuration)	yes, most recent 8 hours of information, for all Multi-Measurement Module and Measurement Extensions measurements	yes, most recent 8 hours of information. A standalone X2/X3 stores all Multi-Measurement Module and Measurement Extension measurements (up to a maximum of 50 measurements). During Companion Mode the X2/X3 stores all Multi-Measurement Module and Measurement Extension measurements and measurements collected by the host monitor from measurement modules (up to a maximum of 50 measurements)
Calculation data (HemoCalc data)	yes	no	no
Events data	yes	no	no

WARNING

If the monitor is not battery-powered, you cannot monitor during transport.

Measurements from **any** Measurement Extension connected to an X2, or from a **previous generation** Measurement Extension connected to an X3, are not available when the X2/X3 is running on its own battery power. They are only available when the X2/X3 is powered by external power: when connected to a host monitor, IntelliVue Dock or to the Battery Extension (865297).

The following sections describe the transfer procedures with a PIC iX, a PIIC or with a standalone monitor.

Data Exchange Between Information Centers

You can transfer demographic data and trend data from one Information Center to another by selecting **Transfer** on the patient monitor. Trend data is not shared between Information Centers and monitors.

Transferring Patients with PIC iX

PIC iX There are several ways to transfer a patient from or to another bed. When a patient is transferred to the destination bed, Information Center monitoring continues in the destination bed and equipment that is not transferred with the patient is freed up.

Using the Transfer Function

PIC iX To transfer a patient using the transfer function provided on the patient monitor by the Information Center:

- 1 Select the patient name or the **Not Admitted** text at the top of the monitor screen to open the **Patient Demographics** window.
- 2 Select the **Transfer** pop-up key.
The **Transfer** window opens. If a patient is currently admitted, the window offers the possibility to transfer that patient to another bed (**To Other Bed**). If no patient is currently admitted, the window offers the possibility to transfer a patient **from** another bed using the patient search as described in “Using “Find Patient” to Search for Patient Data” on page 122.
- 3 With **To Other Bed**, if more than one unit is configured, a list of units will appear. When you have selected a unit, or if only one unit is configured, a list of free beds will appear.
- 4 Select a bed from the list.
You will be asked to confirm the transfer of the patient to this bed.
- 5 Select **Confirm** to complete the transfer.

If the system is configured to support transfer with equipment, the next step is that you move the patient together with the equipment, e.g. multi-measurement module, to the destination bed you have selected. If the equipment is still connected to the source bed, the **Transfer with X2** window opens requesting you to move the patient and equipment, but also offering the possibility to keep the multi-measurement module at the current bed for use with the next patient (with the pop-up key **Keep X2**).

WARNING

Before doing a transfer ensure that no other patient is using the destination bed and/or equipment from the destination bed.

When a patient is transferred you need to check that the patient has all the required monitoring equipment at the destination bed.

Moving the Patient with a Multi-Measurement Module

- PIC iX**
- 1 Connect the Multi-Measurement Module to the patient monitor at the destination bed.
A **Question** window will open, asking whether you want to transfer the patient to this bed.
 - 2 Select the **Yes** pop-up key to complete the transfer.

Using the New Patient Key

PIC iX If the monitor at the destination bed is not free:

- 1 Select the patient name field at the top of the monitor to open the **Patient Demographics** window.
- 2 Select **New Patient** to free up the monitor.
- 3 Select **Find Patient** and enter your patient's name to get the patient data from the system.
When you select your patient from the list, you will be asked to confirm that the patient should be transferred into this bed. After confirmation the transfer is complete.

Transferring Patients with IntelliVue Information Center

Transferring a Centrally-Monitored Patient

- PIIC** Scenario: A centrally-monitored patient is moved to another monitoring location on the same Information Center database server without interrupting the collection of patient trend information.
- 1 Before you disconnect the Multi-Measurement Module from the monitor, select the patient name field or select the **Patient Demogr.** SmartKey to open the **Patient Demographics** window, then select the **Transfer** pop-up key. If the patient is not admitted or not monitored by an Information Center, the **Transfer** key is inactive ("grayed-out").
This step preserves the patient's demographic data during the transfer.
 - 2 Remove the Multi-Measurement Module and any connected extensions from the monitor.
 - 3 Acknowledge the resulting **MMS Unplugged INOP**.
 - 4 Connect the Multi-Measurement Module to the transport monitor and monitor your patient during the move.
 - 5 At the new location, connect the Multi-Measurement Module to the monitor. If the monitor detects a patient mismatch, a window will open showing your patient's data and asking whether to **Complete transfer of this patient?**
 - 6 Select **Yes** to complete the transfer. This re-admits the patient from the transfer list to the new monitor. This will upload the patient demographics, and, if configured, the measurement settings and trend data stored in the Multi-Measurement Module to the receiving monitor.
 - 7 Verify that the settings for patient category and paced mode are correct.

WARNING

Measurements from **any** Measurement Extension connected to an X2, or from a **previous generation** Measurement Extension connected to an X3, are not available when the X2/X3 is running on its own battery power. They are only available when the X2/X3 is powered by external power: when connected to a host monitor, IntelliVue Dock or to the Battery Extension (865297).

Transferring a Centrally-Monitored Patient with X2/X3

- PIIC** Scenario: A centrally-monitored patient is moved to another monitoring location on the same Information Center database server without interrupting the collection of patient trend information.
- 1 Before you disconnect the X2/X3 from the host monitor, select the patient name field or select the **Patient Demogr.** SmartKey to open the **Patient Demographics** window, then select the **Transfer** pop-up key. If the patient is not admitted or not monitored by an Information Center, the **Transfer** key is inactive ("grayed-out").
This step preserves the patient's demographic data during the transfer.

- 2 Remove the X2/X3 and any connected extensions from the monitor.
- 3 Acknowledge the resulting **MMS Unplugged** INOP.
- 4 Move the patient using the X2/X3 as the transport monitor.
- 5 At the new location, connect the X2/X3 to the new host monitor. If the monitor detects a patient mismatch, a window will open showing your patient's data and asking **Complete transfer of this patient?**
- 6 Select **Yes** to complete the transfer. This re-admits the patient from the transfer list to the new monitor. This will upload the patient demographics, and, if configured, the measurement settings and trend data stored in the X2/X3 to the receiving monitor.
- 7 Verify that the settings for patient category and paced mode are correct.

Transferring a Centrally-Monitored Patient with X2 using IIT

PIIC Scenario: A centrally-monitored patient is moved with an X2 to another monitoring location on the same Information Center database server without interrupting the collection of patient trend information. The X2 has an IntelliVue Instrument Telemetry interface (IIT), is connected to a host monitor, and is declared as a telemetry device at the Information Center.

NOTE

The **Transfer** key is **not** available while the X2 is connected to a host monitor (**Companion Mode** is indicated).

- 1 Remove the X2 and any connected extensions from the host monitor.
- 2 Move the patient using the X2 as the transport monitor.
- 3 At the new location, **just before** connecting the X2 to the new host monitor:
 - open the **Patient Demographics** window.
 - select the **Transfer** pop-up key.
 - **wait** until the transfer has completed.
- 4 Connect the X2 to the new host monitor. The monitor detects a patient mismatch and a window will open showing your patient's data and asking **Complete transfer of this patient?**
- 5 Select **Yes** to complete the transfer. This re-admits the patient from the transfer list to the new monitor. This will upload the patient demographics, and, if configured, the measurement settings and trend data stored in the X2 to the receiving monitor.
- 6 Verify that the settings for patient category and paced mode are correct.

If you accidentally transfer a patient, use **Re-Admit** to restore this patient's data to the Information Center. If you are not connected to the network, select **Clear Transfer** to leave transfer mode. The patient data remains in the monitor.

Transferring Patients with Standalone Monitors (No Information Center)

Transferring a Patient with an X1

Scenario: A patient is moved to another monitoring location using a transport monitor and re-admitted at the new monitor.

- 1 Disconnect the X1 from the original monitor and acknowledge the resulting **Unplugged INOP**.
If you are sure that the patient will not be returning to this monitor, you should perform a **Remove Monitor** or **End Case**. This prevents data from the next patient accidentally being mixed up with your current patient's data.
- 2 Connect the X1 to the transport monitor and move the patient.
- 3 At the new monitoring location, remove the X1 from the transport monitor and connect it to the new monitor.
- 4 If prompted, re-admit the patient to the new monitor: in the **Select Patient** window, select the patient in the X1 to retain the data in the X1. This will upload the patient demographics, and, if configured, the measurement settings and trend data stored in the X1 to the monitor. Verify that the settings for patient category and paced mode are correct.

Transferring a Patient with an X2/X3

Scenario: A patient is moved to another monitoring location using the X2/X3 and re-admitted at the new monitor.

- 1 Disconnect the X2/X3 from the original host monitor and acknowledge the resulting **Unplugged INOP**.
If you are sure that the patient will not be returning to this monitor, you should perform a **Remove Monitor** or **End Case**. This prevents data from the next patient accidentally being mixed up with your current patient's data.
- 2 Move the patient using the X2/X3 as the transport monitor.
- 3 At the new monitoring location, connect the X2/X3 to the new host monitor.
- 4 If prompted, re-admit the patient to the new monitor: in the **Select Patient** window of the new monitor, select the patient in the X2/X3 to retain the data in the X2/X3. This will upload the patient demographics, and, if configured, the measurement settings and trend data stored in the X2/X3 to the monitor. Verify that the settings for patient category and paced mode are correct.

Data Upload from a Multi-Measurement Module

The Multi-Measurement Module stores eight hours of patient trend data at one-minute resolution. It also stores patient demographic information and the measurement settings and calibration data for the measurements carried out by the Multi-Measurement Module and any connected extensions. This data can be uploaded to an IntelliVue patient monitor, if your monitor is configured to do so and if at least five minutes of trend information is stored in the Multi-Measurement Module.

Your monitor's data upload settings are defined in Configuration Mode to suit your patient transfer use model.

How data is uploaded to the host monitor depends on the Configuration Mode settings **Trend Upload** and **Settings Upload**.

If there is a patient mismatch and you select **Continue Monitor**, no data will be uploaded from the Multi-Measurement Module.

Resolving Patient Information Mismatch

When you connect together devices which store patient demographic data, for example:

- a Multi-Measurement Module and a monitor,
- an X2/X3 and a host monitor,
- a monitor and an Information Center,

the system compares patient category, paced status, and unique patient identification in order to synchronize this information. If configured to do so, the monitor indicates a mismatch if the information is not identical.

Depending on your monitor's configuration, this mismatch may be automatically resolved or you may have to resolve it manually. If your monitor is configured to resolve mismatches automatically, depending on the configuration, either the monitor or the Multi-Measurement Module data is automatically retained.

WARNING

- It is important to resolve the mismatches as soon as they are identified. Failure to do so could result in using incorrect/confusing data to make clinical decisions. Certain settings, for example **Paced Mode** and **Patient Cat.**, may not match between the Information Center and the monitor. If the **Paced Mode** is set incorrectly, the system could mistake a pace pulse for a QRS and fail to alarm in the case of asystole. It is important that the patient category is set correctly so the ECG can be analyzed correctly and initial arrhythmia alarm limits set. A **Check Patient ID** INOP will appear when a mismatch has not been resolved.
- As long as patient mismatch has not been resolved, data integration in the Information Center and the own patient overview functionality might not work as equipment is not assigned correctly to the patient.

- PIIC**
- When a monitor is connected to an Information Center by the wireless IntelliVue Instrument Telemetry interface, the patient data will automatically be merged in the case of a transfer. This means there is no patient discharge at the monitor and settings and trend data will be retained. You will see a message on the monitor and the **Patient Demographics** window will automatically appear so that you can check the data and change it if necessary.
In the case where an X2 with an *IntelliVue Instrument Telemetry interface* is declared as a "telemetry device" at the Information Center and is connected to a host monitor, it is important to resolve an existing mismatch between the monitor and the Information Center before disconnecting the X2. Failure to do so discharges the X2 and synchronizes the demographics and settings to the Information Center.
-

Manually Resolving Patient Mismatch

The patient mismatch is indicated by question marks (???) beside the questionable fields in the Monitor Info Line and in the **Select Patient** window. The monitor displays a message such as **Different patients in Central and Monitor**.

The **Select Patient** window automatically opens so you can decide which patient data to use. You do not have to resolve the mismatch immediately, but the indicators remain until you do. After 5 minutes a **Check Patient ID** INOP will appear to remind you to resolve the mismatch.

For some common mismatch situations, the monitor will simplify the resolution by suggesting a solution for the mismatch. For example, when a patient arrives after transport and the **Transfer** key has been selected, the monitor will show this patient's data and ask **Complete transfer of this patient?**. You can then select **Yes** to complete the transfer. If you select **No** you will go to the **Select Patient** window.

There can be up to three sets of demographic data in the **Select Patient** window if the patient is different in the Information Center, monitor, and Multi-Measurement Module.

After you resolve the mismatch, the monitor displays a confirmation window that shows the patient that has been selected and where data will be erased, if applicable. Confirm your choice. The monitor automatically displays the **Patient Demographics** window after confirmation. Verify that the settings shown are correct for the patient.

Gender, date of birth, height, weight, and nursing notes do not generate a mismatch. If these fields are different on different devices, the monitor resolves them itself. For example, it may take date of birth from the Information Center, whilst taking gender from the Multi-Measurement Module. Always check the Patient Demographics after combining patients, to ensure that you are satisfied with the results. Change them if necessary.

WARNING

After resolving a patient mismatch, check that the monitor settings (especially patient category, paced status and alarm limits) are correct for the patient.

Patient Mismatch - If One Set of Patient Data is Correct

If there is a mismatch between an Information Center and a monitor, or a monitor and a Multi-Measurement Module, choose the data set you want to continue using for this patient by selecting one of the sectors in the **Select Patient** window.

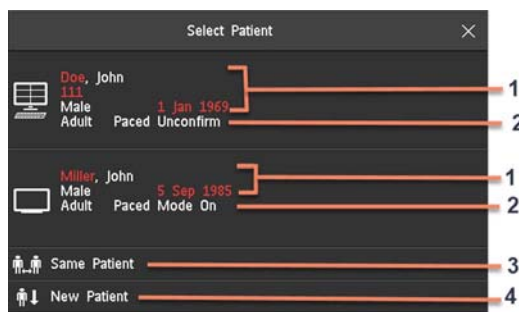

- 1 Patient demographics
- 2 Patient category and paced status
- 3 **Same Patient** - see [“Patient Mismatch - If Both Patient Data Sets Refer to the Same Patient”](#) on page 134.
- 4 **New Patient** - see [“Patient Mismatch - If Neither Patient Data Set is Correct”](#) on page 133.

After you resolve the mismatch, the monitor displays a confirmation window that shows the patient that has been selected and where data will be erased, if applicable. Confirm your choice. The monitor automatically displays the **Patient Demographics** window after confirmation. Verify that the settings shown are correct for the patient.

Patient Mismatch - If Neither Patient Data Set is Correct

A patient mismatch where neither set of patient data is correct might occur if you connect a new Multi-Measurement Module to a monitor in order to prepare for a new patient, before you actually start measuring.

Select **New Patient** if you are sure that none of the information is correct. This uses the bed, monitor and Multi-Measurement Module for a new patient, erases all data in both the monitor and Multi-Measurement Module, resets all settings to the default Profile, and lets you admit a new patient.

Patient Mismatch - If Both Patient Data Sets Refer to the Same Patient

A patient mismatch where both sets of patient data are correct might occur if you admit a new patient at the monitor (or Information Center) before the patient arrives at your unit and then connect the Multi-Measurement Module that was used during the patient transport to the monitor.

Select **Same Patient** if the patient information is different, but you are sure it is the same patient. This merges the demographics and updates them in the Information Center, monitor, and Multi-Measurement Module, according to this table. Be aware that your monitor may be configured to merge trend data from the Multi-Measurement Module and the monitor, and to upload measurement settings from the Multi-Measurement Module to the monitor.

Patient Information	This information is taken from...
Patient name	the monitor, if the patient was admitted there. For centrally-admitted patients, this information is taken from the Information Center.
Patient IDs	
Screen Notes	
Patient Category	the Multi-Measurement Module, if connected, otherwise the data is taken from the monitor.
Date of Birth	
Height	
Weight	
Gender	
Paced Mode	Paced mode is always set to On where there is a mismatch in patient information.
Trend data	if there is newer trend data stored in the Multi-Measurement Module, it is uploaded to the monitor.

Automatically Resolving Patient Mismatch

Your monitor can be configured to automatically resolve mismatches in one of two ways.

- continue using the patient in the Multi-Measurement Module, and delete the old data in the monitor. This is suitable for transport monitors.
- continue with the patient in the monitor, and delete the data in the Multi-Measurement Module.

When automatic mismatch resolution is configured, you may still be asked to confirm the resulting action at the monitor, depending on the current patient admission status.

Managing Equipment

Multiple pieces of monitoring equipment can be used for a patient. The association between a patient and a device can be made by:

- identifying the patient at the device (by entering patient data or using **Find Patient** to get patient data)
- "adding" equipment for an existing patient

The association between a patient and a device can be ended by:

- discharging the patient, or selecting **End Case**.
- "removing" the device from the patient.
- transferring the patient without the device.
- admitting a new patient to the device.
- automatic freeing of the device.

WARNING

In all cases listed above, when equipment is freed, all patient identification and measurement data are deleted, all settings are reset to the defaults, and monitoring at the Information Center (if active) is stopped. Any associated devices, e.g. multi measurement modules connected to a monitor, or cableless measurement devices assigned to a monitor, may also be freed, depending on the configuration.

Adding Equipment (PIC iX)

By selecting the **Add Equipm.** key you can display a list of all free equipment (not currently assigned to a patient) and select a device for use with this patient. If you add another monitor, you need to confirm this at the selected monitor.

For information on combining equipment when connected to a PIIC, see “Using a Telemetry Device and a Monitor (PIIC only)” on page 337.

Removing Equipment

The association between a monitor and the patient can be ended by selecting **Remove Monitor**. With PIC iX, the **Remove Monitor** key is not available when the monitor is locked to a bed.

Other equipment such as telemetry devices or IntelliVue Cableless Measurements can be removed by selecting the device then selecting **Remove** in the menu displayed.



Equipment Status Disputes

Equipment can come into situations where its status does not match its location. There are three typical situations where this may occur:

- PIC iX only - equipment is locked to a bed, but has been removed and used at another bed.
- PIC iX only - equipment has been configured for use in a specific unit, but is now being used in a different unit.
- Equipment has an equipment label but has not been configured at the Information Center and therefore cannot be managed.

If a monitor or a companion device is in one of these situations, a **Check Equipment** INOP will appear and the equipment status will be shown in the **Equipment** window.

The following symbols (in red) are used to show the status in the **Equipment** window:

	equipment is locked to another bed
	equipment is not configured for use in this unit
	equipment label is not in system configuration, or duplicate equipment labels

Using the Equipment Window

In the **Equipment** window you have access to patient management, workflow functions (set location, transfer), equipment management functions (add/remove equipment) and caregiver-related functions.

You can open the **Equipment** window directly in **Main Setup** or by selecting the bed label in the information line.

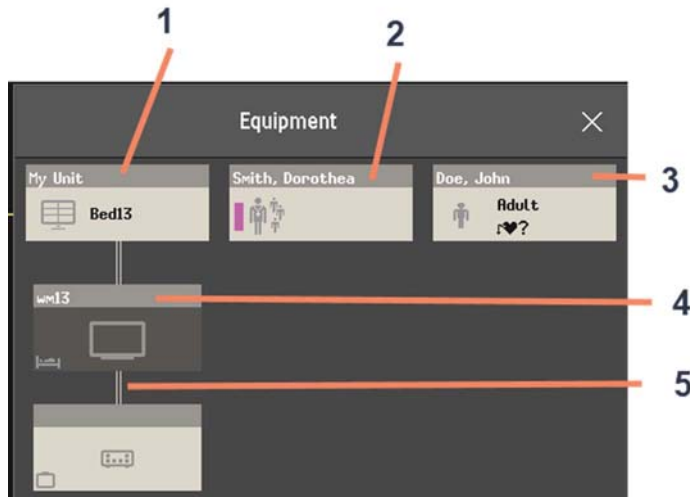

- 1 This bed is Bed 13, the connection to the Information Center is active.
- 2 Name of assigned caregiver
- 3 Patient name, category and paced mode
- 4 This monitor is assigned to the patient and is the one on which you are viewing the window.
- 5 Wired connection

The top part of the window contains the patient data, with the assigned caregiver and the status of the connection to the Information Center, and the bed label. In the lower part of the window, all equipment for this patient is shown, with the corresponding assignments and connections.

The device you are currently viewing the window on is shown with a dark background (in the above example, the monitor with the label wm13).

Changing Caregiver Assignment

When a caregiver is assigned, the caregiver name appears above the caregiver symbol in the **Equipment** window. When you select this area of the window, a menu opens offering the following functions:

- PIC iX**
- **Select Caregiver** - you can select a different caregiver from a list. When a new caregiver is assigned, the patient will be automatically added to that caregiver's Care Group. The availability of the function and the caregiver list depends on the Information Center configuration.
 - **My Patients** - opens the **My Patients** window showing all patients in your Care Group.

Using the Patient Area

The patient name, patient category and paced status are normally shown in the **Equipment** window. When a patient has been prepared for transfer, the transfer symbol will be shown:



When you select this area in the **Equipment** window, a menu opens giving access to the **Enter Patient Demographics** window, the **Transfer** function (see “[Transferring Patients](#)” on page 126) and the **End Case** function.

Changing the Location

If the monitor is currently assigned to a bed, but the patient is in another department for treatment or a diagnostic procedure, you can show a temporary location for the patient.

- 1 Select the Information Center area on the **Equipment** window.
- 2 Select the current location from the list.

Or alternatively use the **Select Location** pop-up key.

The temporary location is then shown in the **Equipment** window, on the Standby screen on the monitor, and in the sector at the Information Center. When the patient returns, you can set the location back to the bed number in the same way as described above.

When Multiple Equipment is Used for One Patient

It is possible to assign additional monitoring equipment and a telemetry device to the same patient, resulting in the information from multiple devices being combined in one sector at the Information Center. The measurement data from the other devices will be displayed on the monitor screen in the own patient overview window.

WARNING

When new equipment has been added for a patient, you will be asked to confirm that the device be used for the patient. Always do this as soon as possible to avoid patient data mismatch.

If multiple equipment is assigned to the patient, resolving a patient mismatch at the monitor may resolve other pending patient mismatches or remove other associated equipment.

Own Patient Overview Window

The measurements from other monitoring devices and telemetry devices are shown combined in the own patient overview window on the monitor, together with related information integrated by the Information Center, such as alarms.

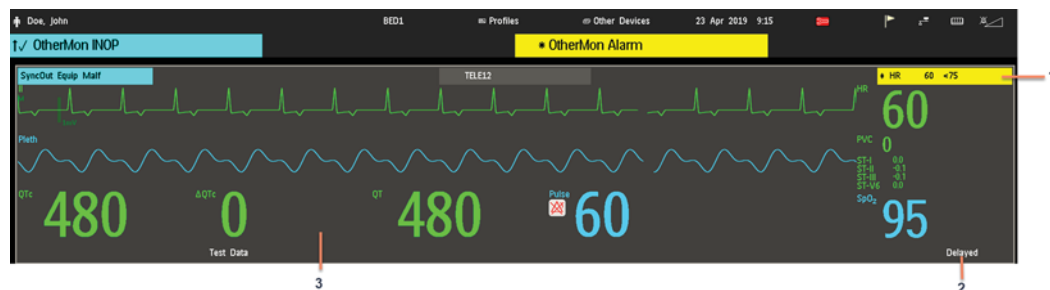

- 1 A current alarm generated by another device.
- 2 **Delayed** - indication that data in the window is delayed.
- 3 Own patient overview window

WARNING

All data presented in the own patient overview window are delayed for several seconds.

If you need realtime data, for example for defibrillation, always use the host monitor ECG instead of telemetry or ECG from another monitoring device. As long as the ECG is being measured with another device there will be no ECG signal available at the ECG analog output.

Visual Alarm Status Information in the Own Patient Overview Window

- If individual measurement alarms are switched off at any of the devices in use for the patient, an alarms off symbol on a white background is shown beside the measurement numeric
- If all alarms are switched off or paused for one of the devices in use for the patient, an alarms off or alarms paused symbol on a dark gray background is shown beside all affected measurement numerics (if so configured). If all red and yellow alarms are switched off/paused, the symbol is red. If only yellow alarms are switched off/paused, the symbol is yellow.



Controlling Other Devices from the Bedside

You can change ECG settings for the current ECG source from the patient monitor.

- 1 Select the own patient overview window.
- 2 Select the **Setup Equipm.** pop-up key.

A setup menu will appear with the settings available for the current ECG source. If it is a telemetry transmitter or patient monitor connected to the Information Center via LAN or WLAN, the following settings are available: adjust HR alarms, relearn arrhythmia, select primary/secondary ECG lead, select arrhythmia analysis mode, change primary/secondary ECG lead size. PIC iX only: if the current ECG source is a patient monitor connected to the Information Center via IntelliVue Instrument Telemetry (IIT), only the adjust HR alarms setting is available.

Viewing and Acknowledging Other Device Alarms at the Bedside

When other devices are assigned to the patient, alarms from those devices will also be indicated on the monitor, in addition to the main indication at the Information Center.

If configured, a generic alarm message will appear in the alarm status area with standard alarm tones. The alarm message will have the color and * or ! coding corresponding to the severity of the alarm. The specific alarm message (for example **** HR Low**) will appear in the own patient overview window.

If configured, alarms generated from another device can be acknowledged at the bedside. Either the monitor **Acknowledge** key is configured to acknowledge both monitor and other device alarms (must be configured at the Information Center) or the **Acknowl. Bed Alms** pop-up key will be available:

- 1 Select the own patient overview window.
- 2 Select the **Acknowl. Bed Alms** pop-up key. Note that this key may be labeled "Silence" on older devices.

Depending on your Information Center configuration, the **Acknowl. Bed Alms** key may acknowledge both other device alarms **and** bedside alarms.

WARNING

Even when the other device data is not visible on the screen, you may be acknowledging monitor alarms **and** other device alarms, if the Information Center and monitor are so configured.

Switching Off or Pausing Alarms From Other Devices

When you select **Pause Alarms** or **Alarms Off** at the monitor, the alarms are off or paused for the bedside measurements. When you switch alarms off or pause alarms at the Information Center, both monitor alarms and alarms from other assigned devices are affected.

Refer to the Information Center Instructions for Use for more details on the Suspend/Pause alarms behavior of the Information Center.

Using Standby

When you select Standby mode at the monitor, the bedside goes into Standby mode but other assigned devices may continue monitoring.

Refer to the Information Center Instructions for Use for details on how selecting Standby at the Information Center affects the monitor and other devices.

ECG Source Tracking at the Information Center

The Information Center continuously checks whether a valid ECG signal is coming from the monitor or from another assigned device. If you unplug the ECG patient cable from the monitor and plug it into another device, the Information Center will automatically switch to monitoring the ECG from the other device. At the monitor, its own ECG measurement will be deactivated and the **Setup ECG** menu will no longer be accessible.

When you unplug the patient cable from the other device and plug it back into the monitor again, the Information Center will switch back to monitoring the ECG from the monitor. The ECG measurement will be activated again at the monitor. [Note that in this case, as the screen switches back to the monitor's own measurements, the SpO₂T measurement (if present) will no longer be displayed].

In the same way the source is tracked when a telemetry device is directly connected to a monitor, then disconnected and vice versa.

In case of ambiguity, a yellow INOP message **!! Check ECG Source** indicates that more than one valid ECG source is active.

Synchronized Settings

For some measurements, settings can be synchronized between the monitor and another measurement device. For example, if ECG is measured at the monitor, and then the patient is connected to a telemetry device for monitoring, the Information Center will use the monitor settings for the telemetry device. In general, the following settings will be synchronized:

Heart Rate	HR/Pulse Alarm On/Off, Heart Rate High/Low Limit
ECG	ECG On/Off ¹ , Primary Lead, Secondary Lead, Va Lead, Vb Lead, Lead Placement
Arrhythmia	Analysis Mode, Arrhythmia On/Off, Asystole Threshold, Pause Threshold, VTach HR, VTach Run, PVCs/min, Vent. Rhythm, SVT HR, SVT Run, PVCs/min On/Off, Pacer not capture On/Off, Pacer not pace On/Off, Non-Sustain On/Off, Vent. Rhythm On/Off, Run PVCs On/Off, Pair PVCs On/Off, Missed Beat On/Off, Pause On/Off, R-on-T PVCs On/Off, Vent. Bigeminy On/Off, Vent. Trigeminy On/Off, Multifform PVCs On/Off, Irregular HR On/Off, SVT On/Off, Afib On/Off, Afib/IrrHR End Threshold, All ECG Alarm INOP mode.
ST	ST Analysis On/Off, ST Alarm On/Off, ISO Point, J point, ST point, ST Alarm Limits, ST-Index On/Off, ISO/J-Point Detection, ST Lead On/Off, ST Baseline
QT	QT analysis On/Off, QT Lead, QTc High Alarm On/Off, ΔQTc Alarm On/Off, QTc High Limit, ΔQTc High Limit, QT Baseline ²

4 Managing Patients and Equipment

SpO ₂ T	SpO ₂ Alarms on/off, SpO ₂ Alarm limits, SpO ₂ Low Alarm Delay, SpO ₂ High Alarm Limit, Desat Alarm Limit NBP Alarm Suppression On/Off, Pulse(SpO ₂) On/Off
¹ ECG On/Off setting is forced to ON by the monitor, if the local setting is ON.	
² With PIIC, QT baseline is synchronized, but not QT snippets.	

PIC iX With the Patient Information Center iX, the following additional measurement settings can be synchronized:

ECG/Arrhythmia	Some ECG Alarms INOP On/Off, Hexad Reconstruction Mode
ST	STE On/Off, STE Alarm On/Off
NBP	Sys/Dia/Mean Alarm Limits, Alarms On/ Off, Alarm Source
Resp	Apnea Time, Alarm Limits, Alarm On/Off, Resp On/Off
SpO ₂	SpO ₂ Alarms on/off, SpO ₂ Alarm limits, Desat Alarm Limit, NBP Alarm Suppression On/Off, Pulse(SpO ₂) On/Off, Measurement Mode ¹ , Repetition Time ¹
¹ Measurement Mode and Repetition Time can only be synchronized if SpO ₂ comes from a Cableless SpO ₂ Pod or a telemetry device.	

WARNING

- Not all settings are synchronized; after changing the measurement source, always check that the settings are appropriate.

If later the patient is disconnected from the other device, and reconnected to the monitor again, any changes in the settings made in the meantime will be passed on to the monitor. In this way, settings continuity is preserved when the measurement source changes.

NOTE

Settings synchronization can be switched off at the monitor in Configuration mode.

In certain situations, you will be asked to confirm that synchronization of settings is appropriate.

Settings synchronization can only take place when there is no patient information mismatch between the monitor and the Information Center.

PIIC If a **Check ECG Settings** or **!! Check Pairing** INOP appears always check that the ECG settings, especially the paced setting, are appropriate for your patient.

PIC iX If a **Check ECG Settings**, **Chk SpO₂T Settings**, or another check settings INOP appears, always check that the settings, especially the paced setting for ECG, are appropriate for your patient.

Care Groups

If your monitor is connected to an Information Center, you can group bedside monitors into Care Groups to facilitate caregiver assignment. This lets you:

- view information on the monitor screen from another bed in the same or in a different Care Group.
- be notified of yellow or red alarm conditions at the other beds in the Care Group.
- see the alarm status of all the beds in the Care Group on each monitor screen.

The functions available with Care Groups depend on the Information Center revision your monitors are connected to. See your Information Center Instructions for Use for further details.

Care Groups in PIC iX

Units and Care Groups can be configured at the Information Center. The available sizes for units and Care Groups are defined by the Information Center. Monitors can be added to or removed from an existing care group at the monitor by assigning a new caregiver.

Care Groups in PIIC

There are two main types of Care Groups:

- standard care group (**Bed-based Care Group**) - up to 12 patients monitored by up to 4 Information Centers
- unit group (**Unit-based Care Group**) - for a complete unit with up to 64 patients monitored by up to 4 Information Centers

Care Groups are configured at the Information Center. Monitors can be added to or removed from an existing care group at the monitor. There is a third care group which can be assigned locally at the bedside. This is the **My Central** care group which includes all beds (up to 16) from the Information Center your bed is connected to. This care group setting is typically used in facilities with only one Information center. The selection of beds is automatic and cannot be changed.

Understanding the Alarm Status Overview Bar









The Care Group monitors' and equipment status is shown in symbol form in the alarm status overview bar. Flashing symbols indicate active alarms, symbols that are not flashing indicate alarms that have been acknowledged. Selecting a bed symbol calls up the window for that bed or a setup window to select it. Because multiple equipment can be used for one patient, it can occur that the alarm status is different at different devices. The alarm status will then be consolidated and the highest priority alarm information will be displayed.

The alarm status overview bar must be configured to display on the monitor Screen. If it is not visible on your monitor, select a Screen which has been configured to show the bar. Some screens may show the Care Group monitors grouped together in a tabular format on the right hand side of the screen.

PIC iX Depending on the Information Center configuration, the alarm status overview bar may contain My Patients (your own care group), My Unit (all beds from the unit) or it may not display at all.

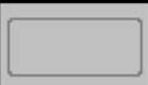
WARNING

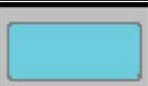
With PIC iX, the alarm status overview bar is independent from the configured alarm pop-up behavior.



Alarm Status Symbols (four alternative display possibilities depending on space available)				
				No data from this bed
		Bed 8	Bed 8	The alarms are on but there are no currently active alarms from this bed
		Bed 5	Bed 5	The highest priority alarm from this bed is a standard INOP
	*	Bed 14	* Bed 14	The highest priority alarm from this bed is a short yellow alarm

Alarm Status Symbols (four alternative display possibilities depending on space available)				
	**	Bed 11	** Bed 11	The highest priority alarm from this bed is a yellow alarm
	***	Bed 9	*** Bed 9	The highest priority alarm from this bed is a red alarm
	!!	Bed 7	!! Bed 7	The highest priority alarm from this bed is a yellow INOP
	!!!	Bed 6	!!! Bed 6	The highest priority alarm from this bed is a red INOP
			Bed 4	The alarms at this bed are suspended. The same symbols in yellow indicate that yellow alarms are suspended (PIC iX only).
			Bed 12	Equipment at this bed is in standby mode
	DEMO	DEMO	DEMO	Equipment at this bed is in Demonstration mode
		Bed 3	Bed 3	The current bed

NOTE

Be aware that the maximum space available to show the bed label on the alarm status overview bar is six characters. As bed labels at the Information Center can have up to eight characters, this can result in bed labels being automatically shortened for display in the overview bar. Windows, such as the Other Bed window, **My Patients** window, **My Unit** window, and **AlarmingBeds** window, display the full bed label. If the shortened bed labels in the overview bar cause difficulty in identifying beds, consider changing the bed labels at the Information Center to ensure that the first six characters include the identification.

Connection Symbols (used in the Alarm Status overview bar and the My Patients window)		
		This is a telemetry bed.
		This bed is on a wireless network.
		This bed is on a wired network.

Connection Symbols (used in the Alarm Status overview bar and the My Patients window)	
	PIC iX only: Patient has multiple devices assigned.
	PIIC only: This is a "paired" bed, with a bedside monitor and a telemetry transmitter assigned.

Viewing the My Patients Window

This window shows the alarm status, bed name, and patient name for every bed in the Care Group.

The window for the Unit group shows first the beds of the Information Center this bed is connected to. By selecting the Information Center name at the top of the list, you can display a list of all Information Centers associated with the Unit group, and select another Information Center to view.

To enter the window for your own care group,

- select the **My Patients** SmartKey, if configured, or
- in the **Main Setup** menu, select **My Patients**.

Use the pop-up keys to navigate through the Care Groups:

My Unit lets you view a list of all the Information Centers in your Care Unit. Select an Information Center to see a list of the monitors connected to it. Select any monitor to see the Other Bed window for that bed.

Alarming Beds lets you view a list of all beds in your care group with an unacknowledged alarm. The beds are listed in order of alarm severity.

PIIC Other Units lets you view a list of all the Care Units in your Care Domain. Select any Care Unit to view a list of the Information Centers connected to it. Select an Information Center to see a list of the monitors connected to it. Select any monitor to see the Other Bed window for that bed.

PIC iX Other Patients lets you search for a patient or step through lists by unit and bed label to select another patient.

Viewing the Other Bed Window

The Other Bed window lets you view a subset of the waveform and numeric information from another bed on the same network. Waves and numeric information from another bed are delayed. If configured, Other Bed information is displayed in color, using the colors defined by the Information Center.

The Other Bed window can be configured to pop-up automatically when an alarm occurs at another bed. To avoid too many windows appearing (for example, in large care groups) and covering the monitor's own bed data on the screen, you can temporarily disable this automatic pop-up:

- 1 Select **Main Setup** then **Network** followed by **Auto Window**
- 2 Select **Disabled**

When automatic pop-up is disabled in this way, an icon will appear as a reminder in the Care Group



Overview Bar next to the monitor's own bed label. Depending on the configuration, the automatic pop-up is disabled for five minutes or until you set it to **Enabled** again.

4 Managing Patients and Equipment

Automatic pop-up is also disabled when the visitor Screen is selected at the monitor.

- To open the Other Bed window, select the required bed label or patient name in the Alarm Status Overview Bar. If you are in a Unit Group with many beds, the **My Patients** window may open for you to select the bed.



The Other Bed window may be configured to display embedded in a specially designed Screen.

- To display the embedded Other Bed screen element, in the **Change Screen** menu, select a Screen designed to show the Other Bed information permanently.



Changing the Screen may automatically change the bed shown in the other bed window. If you switch to a different Screen, you should check that the correct other bed is displayed.

Other Bed Pop-Up Keys

Select the **Other Patients** SmartKey or the Other Bed window or embedded screen element to access the associated pop-up keys:

Next Wave lets you view waveforms not currently shown in the Other Bed window.

More Vitals lets you view more numerics not currently shown in the Other Bed window.

Next Patient lets you view waveforms and numerics from the next available patient in the Care Group.

My Patients lets you call up the **Care Group** window to select another patient.

Alarming Beds lets you view a list of all beds in your care group with an unacknowledged alarm. The beds are listed in order of alarm severity. With PIC iX, the **Alarming Beds** window may also contain beds that are not in your Care Group that have been escalated for higher attention.



Acknow. Bed Alms lets you acknowledge active alarms at the other bed. Note that this key may be labeled "Silence" on older devices. (Whether you see this key depends on the revision and configuration of the Information Center your monitors are connected to.)

WARNING

The **Acknowl. Bed Alms** pop-up key in the Other Bed window acknowledges alarms at a remote bed. Be aware that accidental use of this key could acknowledge alarms for the wrong patient.

To acknowledge own bed alarms, use the Acknowledge permanent key on screen.

Visual Alarm Status Information in the Other Bed Window

- If individual measurement alarms are switched off at any of the devices in use at the other bed, a crossed alarm symbol in red on a white background is shown beside the measurement numeric. 
- If all alarms are switched off or paused for one of the devices in use at the other bed, a crossed alarm symbol on a black background is shown beside all affected measurement numerics (if so configured). If all red and yellow alarms are switched off/paused, the crossed alarm symbol is red. If only yellow alarms are switched off/paused, the crossed alarm symbol is yellow. 
- In the embedded Other Bed window, the crossed speaker symbol in the upper right hand corner indicates that the volume of the audible alarm status change notification for the other beds in the care group is set to zero at the overview monitor. 

Other Patient Alarms

Changes in the alarm status of beds in a Care Group are announced visually and audibly at all other beds in the same Care Group. The visual and audible indicators used depend on the monitor and Information Center configuration.

When an alarm is detected at another bed in the Care Group,

- the alarm status is shown in the Alarm Status overview bar as an icon.
- a message informing you about the other patient alarm is shown in the monitor status line.
- if configured, the Other Bed window, the **Alarming Beds** window or the **My Patients** window may pop up on the Screen (if automatic alarm notification is enabled at the bedside monitor and at the Information Center). The automatic alarm notification is suppressed when a window, menu or pop-up keys are active.
- if configured, an audible status change notification is issued. The tone type and volume can be configured.

PIC iX Automatic alarm notification can also cause a window to pop-up when a patient from outside the Care Group has been escalated to a higher attention status. Check that the detailed configuration at the PIC iX meets your unit's requirements.

Automatic alarm notification can be switched off permanently in the monitor's Configuration Mode or at the Information Center.

Information Center Compatibility

The functionality available for managing patients and equipment depends on the Information Center being used. In the following table the main differences between the PIIC and PIC iX are shown.

PIIC	PIC iX
Not available	Find Patient - searching for a patient in the Information Center or other connected hospital systems. (With LAN and WLAN connection only)
Transfer Patient - patient is moved to transfer list.	Transfer Patient - can transfer patient directly to another bed/unit and from another bed/unit. (With LAN and WLAN connection only)
Not available	A unique patient list provides information about the current status of a patient allowing intelligent prompts and preventing the same patient being admitted twice.
Add Equipment - allows only assignment of telemetry devices via manual pairing.	Add Equipment - allows assignment of other monitors, telemetry devices and X2/X3 Multi-Measurement Modules. (With LAN and WLAN connection only)
Remove equipment - allows only removal of telemetry devices via Unpair To Mon. and Unpair To Tele.	Remove <Device> - allows removal of other monitors, telemetry devices and X2/X3 Multi-Measurement Modules.
Not available	Select Location - allows a temporary location to be shown when a patient is not in the unit. (With LAN and WLAN connection only)
Not available	Select Caregiver - allows a Caregiver to be assigned to a patient.
Not available	Paced status Unconfirmed is the initial setting before a paced status has been entered. Unconfirmed will switch pace pulse rejection on but makes the user aware that no paced status has been selected.

ECG, Arrhythmia, ST and QT Monitoring

The electrocardiogram (ECG) measures the electrical activity of the heart and displays it on the monitor as a waveform and a numeric. This section also tells you about arrhythmia monitoring (see “[About Arrhythmia Monitoring](#)” on page 169), ST monitoring (see “[About ST Monitoring](#)” on page 179) and QT monitoring (see “[About QT/QTc Interval Monitoring](#)” on page 190).

Skin Preparation for Electrode Placement

Good electrode-to-skin contact is important for a good, noise-free ECG signal, as the skin is a poor conductor of electricity.

- 1 Select sites with intact skin, without impairment of any kind.
- 2 Clip or shave hair from sites as necessary.
- 3 Wash sites thoroughly with soap and water, leaving no soap residue.
We do not recommend using ether or pure alcohol, because this dries the skin and increases the resistance.
- 4 Dry skin thoroughly.

Connecting ECG Cables

- 1 Attach the clips or snaps to the electrodes before placing them. If you are not using pre-gelled electrodes, apply electrode gel to the electrodes before placement.
- 2 Place the electrodes on the patient according to the lead placement you have chosen.
- 3 Attach the electrode cable to the patient cable.
- 4 Plug the patient cable into the white ECG connector. An ECG waveform and numeric appears on the monitor display.

CAUTION

To protect the monitor from damage during defibrillation, for accurate ECG information and to protect against noise and other interference, use only ECG electrodes and cables specified by Philips. Some non-authorized electrodes may be subject to large offset potentials due to polarization.

Selecting the Primary and Secondary ECG Leads

The monitor uses the primary and secondary lead to compute HR and to analyze and detect cardiac arrhythmias. They are also available for recordings and for display on the Information Center.

The secondary lead is only used if your monitor is configured for multi-lead (instead of single-lead) arrhythmia analysis.

You should choose a lead as primary or secondary lead that has the following characteristics:

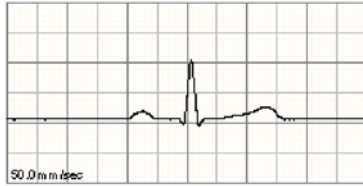

- the QRS complex should be either completely above or below the baseline and it should not be bi-phasic
- the QRS complex should be tall and narrow
- the T-wave is less than 1/3 the R-wave height
- the P-wave is less than 1/5 the R-wave height, preferably less than 0.15 mV.

To select a lead as primary or secondary lead:

- In the **Setup ECG** menu, select **Primary** or **Secondary**, then select the appropriate lead. You can assign any available lead whether it is currently displayed or not.

Checking Paced Mode

It is important to set the paced mode correctly when you start monitoring ECG.

- To change the paced mode in the **Setup ECG** menu, select **Paced Mode** to switch between **On**, **Off** or **Unconfirmed**.

WARNING

Pace pulse rejection must be switched on for paced patients by setting **Paced Mode** to **On**. Switching pace pulse rejection off for paced patients may result in pace pulses being counted as regular QRS complexes, which could prevent an asystole event from being detected. When changing profiles, and at admission/discharge, always check that paced mode is correct for the patient.

Some pace pulses can be difficult to reject. When this happens, the pulses are counted as a QRS complex, and could result in an incorrect HR and failure to detect cardiac arrest or some arrhythmias. Make sure that pace pulses are detected correctly by checking the pace pulse markers on the display. Keep pacemaker patients under close observation.

Understanding the ECG Display

Your display may be configured to look slightly different.

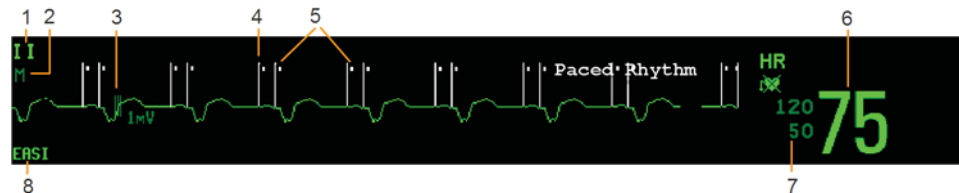

- 1 Lead label of the displayed wave
- 2 ECG Filter label
- 3 1 mV calibration bar
- 4 Pacer spikes
- 5 Pace pulse markers
- 6 Current heart rate
- 7 Current heart rate alarm limits and paced mode symbol
- 8 EASI or Hexad lead placement label

ECG HR numeric: This is the heart rate derived from the monitored ECG.

Pace pulse markers: These are shown if the **Paced Mode** status has been set to **On**, the pacer spikes are not configured to have a fixed size, and the patient has a paced signal.

Pacer Spikes: The pacer spikes are shown in white, unless the ECG wave is white, then they will be green. If the pacer spikes have been configured to have a fixed size, they will be displayed in the background as a dotted line.

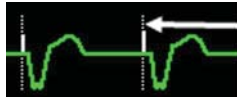

1 Pacer spikes configured to have a fixed size

Synchronization marks: If the 2nd Sync Out channel is configured to **ECG SyncPuls**, a sync cable is connected, and the synchronization pulse is configured to be shown, synchronization marks (vertical lines on the ECG wave) are shown on the ECG wave. The synchronization marks will be shown in yellow, unless the ECG wave is yellow, then they will be green.



1 Synchronization marks in yellow

ST numerics in ECG wave: ST numerics can be configured to show underneath the ECG wave on the left side.

Hexad lead placement label: When 6-lead placement for a Hexad derived 12-lead ECG is used, the **Hexad** lead placement label is displayed and all derived leads are marked with a "d" in front of the lead label, for example dV1.

Monitoring Paced Patients

An ECG optimized for monitoring a paced patient should look like this:

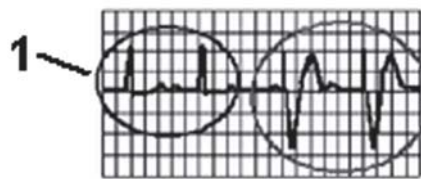

1 Normal Beats
2 Pace Pulses/Pace Beats

You should choose a lead as primary or secondary lead that has these characteristics:

- the normal QRS complex should be either completely above or below the baseline and it should not be bi-phasic. For paced patients, the QRS complexes should be at least twice the height of pace pulses.
- the QRS complex should be tall and narrow
- the T-wave is less than 1/3 the R-wave height
- the P-wave is less than 1/5 the R-wave height, preferably less than 0.15 mV.

For ease of identification on the screen, the pacer spikes can be configured to have a fixed size. They are then shown in the background as dotted lines. The length of the dotted line is fixed to the wave channel height and is independent of the actual pacer amplitude.

Setting the Paced Mode (Pace Pulse Rejection)

In the **Setup ECG** menu, select **Paced Mode** to switch between **On**, **Off** or **Unconfirmed**.

You can also change the paced mode in the **Patient Demographics** window.

When **Paced Mode** is set to **On**:

- Pace Pulse Rejection is switched on. This means that pacemaker pulses are not counted as extra QRS complexes.
- pace pulse marks are shown on the ECG wave as a small dash (only when the pacer spikes are not configured to have a fixed size).
- The paced symbol is displayed next to the HR numeric.

When **Paced Mode** is set to **Off**, pacer spikes are not shown in the ECG wave. Be aware that switching pace pulse rejection off for paced patients may result in pace pulses being counted as regular QRS complexes, which could prevent an asystole event from being detected.

When the paced mode has not yet been set for a patient, the paced symbol will have a question mark indicating the **Unconfirmed** mode. When the paced mode is **Unconfirmed**, pace pulse rejection is switched on.

Paced Mode On



Paced Mode Off



Paced Mode Unconfirmed



Avoiding Pace Pulse Repolarization Tails

Some unipolar pacemakers display pace pulses with repolarization tails. These tails may be counted as QRSs in the event of cardiac arrest or other arrhythmias.

If you note a visible repolarization tail, choose a lead that decreases the size of the repolarization tail.



1 Repolarization tail (note width)

Changing the Size of the ECG Wave

If any of the displayed ECG waves is too small or clipped, you can change the size of one or all of the ECG waves on the screen.

Changing the adjustment factor only changes the visual appearance of the ECG wave on the screen. It does not affect the ECG signal analyzed by the monitor.

Comparing the wave size to the 1 mV calibration bar on the ECG wave channel can help you to get an idea of the true ECG signal strength. If you choose a fixed adjustment factor, the 1 mV calibration bar will be the same size for all the displayed ECG waves. If you choose **Auto Size**, or an individual size using the **Size Up/Size Down** keys, the calibration bar may be a different size for each wave.

Using any of the options to change the wave size will automatically reposition the wave in the middle of the channel, standardizing the offset. You can use this effect to reposition your waves, if they are shown at the top or bottom of the channel, or even clipped. Correct positioning, and a standardized offset, is also important for recordings and reports, to allow reliable interpretation of the data.

To Change the Size of an Individual ECG Wave

- 1 Select the wave channel you want to change. This calls up the lead menu for this channel.
- 2 In the lead menu, select **Size Up** to increase wave size or **Size Down** to decrease the size.
Selecting **Auto Size** lets the monitor choose the optimal adjustment factor for all available ECG waves.

To Change the Size of all the ECG Waves

To change the size of all the ECG waves on the screen by a fixed adjustment factor,

- 1 In the **Setup ECG** menu, select **Adjust Size**.
- 2 Select the required adjustment factor from the line of pop-up keys.
 - **Size x0.5** to halve the wave size
 - **Size x1** to display the wave without zoom
 - **Size x2** to double the wave size
 - **Size x4** to multiply the wave size by four
 - **Previous Size:** to return one step to the previous size
 - **Auto Size:** to let the monitor choose the optimal adjustment factor for all the ECG waves.

Changing the Minimum QRS Detection Threshold

A major goal of the QRS detection algorithm is to avoid P-waves, T-waves and noise from being detected as QRS complexes. The QRS detection threshold is the level above which peaks will be counted as QRS complexes. The actual threshold at any time depends on the noise present and the shape of the original ECG signal.

The default level for the minimum detection threshold is 150 μV . If you have an ECG signal with high P and/or T-waves, check whether one of the available leads has a less pronounced P/T-wave. If this is not the case, you can adjust the minimum detection threshold to a level higher than the P/T-waves.

To adjust the threshold:

- 1 Enter the **Setup ECG** menu.
- 2 Select **QRS Detection**.
- 3 Select a value from the pop-up menu.
The values are shown in microvolts. For comparison, you can refer to the 1 millivolt calibration bar on the wave. 1 millivolt equals 1000 microvolts.

Changing the Volume of the QRS Tone

The QRS tone is derived from either the HR or Pulse, depending on which is set up as QRS tone source. The QRS volume can be set from 0 to 10 (0 means off).

To change the QRS volume, in the **Setup ECG** menu select **QRS Volume** and then select the appropriate volume from the pop-up list.

Changing the ECG Filter Settings

The ECG filter setting defines how ECG waves are smoothed. An abbreviation indicating the filter type is shown underneath the lead label on the monitor display. Filter settings do not affect ST measurement.

To change the filter setting, in the **Setup ECG** menu, select **Filter** and then select the appropriate setting.

- **Monitor:** Use under normal measurement conditions.
- **Ext. Monitor:** Use when diagnostic quality is required but low frequency interference or a wandering baseline may be expected. The upper edge frequency is the same as the **Diag** setting and the lower edge frequency is the same as the **Monitor** setting.
- **Filter:** The filter reduces interference to the signal. It should be used if the signal is distorted by high frequency or low frequency interference. High frequency interference usually results in large amplitude spikes making the ECG signal look irregular. Low frequency interference usually leads to a wandering or rough baseline. In the operating room, the Filter reduces artifacts and interference from electrosurgical units. Under normal measurement conditions, selecting **Filter** may suppress the QRS complexes too much and thus interfere with the clinical evaluation of the ECG displayed on the monitor. This does not affect the ECG analysis performed by the monitor.

If **AutoFilter** is set to **On** in Configuration Mode, the filter setting will automatically be set to **Filter** if electromagnetic interference is detected.

- **Diag:** Use when diagnostic quality is required. The unfiltered ECG wave is displayed so that changes such as R-wave notching or discrete elevation or depression of the ST segments are visible.

The setting **Diag** selects the highest available ECG bandwidth which is 0.05 to 150 Hz for the Adult, Pedi and Neo patient category. The term "diagnostic" relates only to the ECG bandwidth requirements for diagnostic electrocardiographic devices as outlined in the ANSI/AAMI standard EC11-1991.

Choosing EASI or Standard Lead Placement

You must enable either standard lead placement or EASI lead placement.

- In the **Setup ECG** menu, select **Lead Placement** and then **Standard** or **EASI**.

EASI is shown beside the 1 mV calibration bar on the ECG wave on the display, and **EASI** is marked on any recorder strips and printouts.

See the section on “[EASI Lead Placement for a 5-Electrode Cable Set](#)” on page 159 for electrode placement diagrams.

If you are using the Hexad derived 12-lead, you need to select **Standard** lead placement here.

Selecting Positions of Va and Vb Chest Leads (for 6-electrode placement)

6-Electrode Lead Placement

The two chest electrodes for the 6-electrode lead placement can be positioned at any two of the V1 to V9 and V3R to V6R positions. Select the positions you have used in the **Setup ECG** menu, so that the chest leads will be correctly labeled.

- 1 In the **Setup ECG** menu, select **Va Lead**.
- 2 Select the position used from the list.
- 3 Select **Vb Lead** and select the position used from the list.

6-Electrode Placement for Hexad Derived 12-lead ECG

The Hexad ECG lead system uses a 6-electrode cable set, connected to four limb electrodes (using Mason-Likar placement) and two chest electrodes. The algorithm derives the four remaining V-leads to provide a non-diagnostic 12-lead view, including ECG waves and ST/QT measurements.

The two chest electrodes for Hexad must be positioned at two of the V1 to V6 positions. The following combinations of positions can be used:

- V1 and V3
- V1 and V4
- V1 and V5
- V2 and V4
- V2 and V5
- V3 and V5
- V3 and V6

Select the two positions you have used in the **Setup ECG** menu:

- 1 In the **Setup ECG** menu, select **Hexad (Va,Vb)**.
- 2 Select the correct combination of chest electrode positions from the list.

Making the selection switches the Hexad derived 12-lead ECG on.

The Hexad derived 12-lead ECG is intended for use with adult patients only. For this reason, the **Hexad (Va,Vb)** selection will not be available in neonatal and pediatric modes.

About ECG Leads

To make it possible to compare measured ECG signals, the electrodes are placed in standardized positions, forming so-called "leads". To obtain ECG signals optimized for use in diagnosis and patient management in different care environments, different electrode cable sets in varying lead placements can be used. You can use either standard lead placements or EASI lead placements with this monitor.

When placing electrodes, choose a flat, non-muscular site where the signal will not be interfered with by either movement or bones. Correct electrode placement is always important for accurate diagnosis. Especially in the precordial leads, which are close to the heart, QRS morphology can be greatly altered if an electrode is moved away from its correct location.

ECG Leads Monitored

If you are using	these leads are available:
a 3-electrode set	I, II, III
a 5-electrode set	I, II, III, aVR, aVL, aVF, V, MCL, Va
a 6-electrode set	I, II, III, aVR, aVL, aVF, Va, Vb
a 6-electrode set with the Hexad algorithm	I, II, III, aVR, aVL, aVF, V1, V2, V3, V4, V5, V6 Two V leads are directly measured and four are derived.
a 10-electrode set	I, II, III, aVR, aVL, aVF, V1, V2, V3, V4, V5, V6
an EASI 5-electrode set	I, II, III, aVR, aVL, aVF, V1, V2, V3, V4, V5, V6

Changing the Number of Electrodes

To change the number of electrodes,

- **When adding electrodes:** place the additional electrodes as required - the monitor automatically recognizes the new lead placement.
- **When removing electrodes:** there are two possibilities - removing the complete chest leads block or removing individual electrodes.

If you unplug the chest lead block from the trunk cable connector, the monitor will automatically

recognize the new lead placement.

Remove individual leads by removing the electrodes. The monitor will issue a **Lead Off INOP** message; select **New Lead Setup** in the **Setup ECG** menu and the INOP message will disappear.

ECG Lead Fallback

If fallback is configured on and there is a leads off INOP in the primary lead (and in the secondary lead, if you are using multi-lead monitoring) for longer than 10 seconds, and if another lead is available, this available lead automatically becomes the primary lead. This is known as lead fallback. When the Leads Off condition is corrected, the leads are automatically switched back.

This setting can only be changed in Configuration Mode.

ECG Lead Placements

The labels and colors of the ECG electrodes differ according to the standards that apply for your hospital. The electrode placement illustrations in this chapter use the AAMI labels and colors.

Electrode labels			Electrode colors	
AAMI	EASI	IEC	AAMI	IEC
RA	I	R	White	Red
LA	S	L	Black	Yellow
LL	A	F	Red	Green
RL	N	N	Green	Black
V	E	C	Brown	White
V1/Va		C1/Ca	Brown/Red	White/Red
V2/Vb		C2/Cb	Brown/Yellow	White/Yellow
V3		C3	Brown/Green	White/Green
V4		C4	Brown/Blue	White/Brown
V5		C5	Brown/Orange	White/Black
V6		C6	Brown/Violet	White/Violet

Lead Placement for a 3-Electrode Cable Set

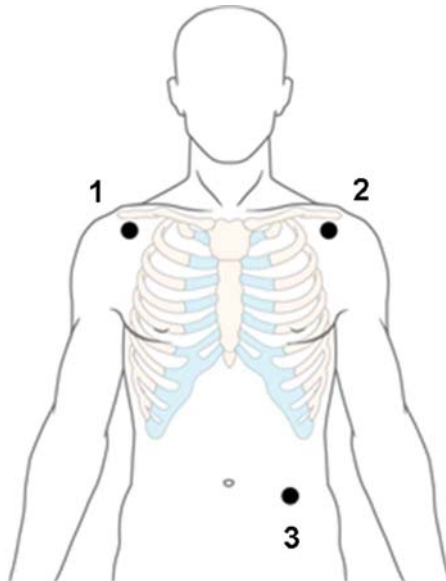

- 1 RA placement: directly below the clavicle and near the right shoulder
- 2 LA placement: directly below the clavicle and near the left shoulder
- 3 LL placement: on the left lower abdomen

Lead Placement for a 5-Electrode Cable Set

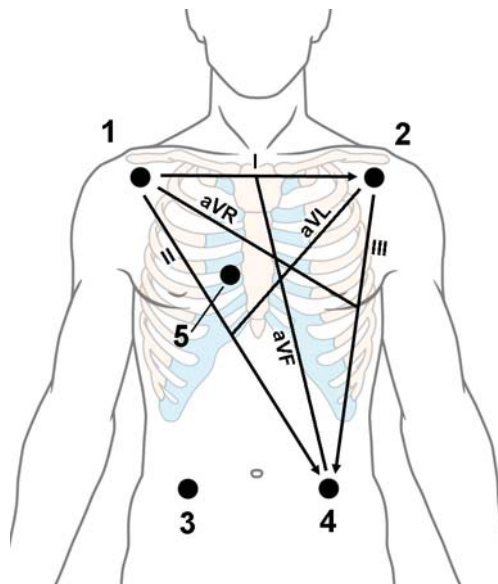

- 1 RA placement: directly below the clavicle and near the right shoulder
- 2 LA placement: directly below the clavicle and near the left shoulder
- 3 RL placement: on the right lower abdomen
- 4 LL placement: on the left lower abdomen
- 5 V placement: on the chest, the position depends on your required lead selection. If configured, the label of the chest lead will be displayed with its exact position (V1 to V6R)

Lead Placement for a 6-Electrode Cable Set

Use the positions from the 5-electrode diagram above but with two chest leads. The two chest leads, Va and Vb, can be positioned at any two of the V1 to V9 or V3R to V6R positions shown in the chest electrode diagram below (see “Chest Electrode Placement” on page 156).

The Va and Vb lead positions chosen must be selected in the **Setup ECG** Menu.

Hexad Lead Placement for a 6-Electrode Cable Set

Use the positions from the 5-electrode diagram above but with two chest leads. For Hexad derived 12-lead, the two chest leads, Va and Vb, must be positioned at two of the V1 to V6 positions shown in the chest electrode diagram below (see “Chest Electrode Placement” on page 156). The following combinations of positions can be used:

- V1 and V3
- V1 and V4
- V1 and V5
- V2 and V4
- V2 and V5
- V3 and V5
- V3 and V6

The Va and Vb lead positions chosen must be selected in the **Setup ECG** Menu.

When Hexad lead placement is selected, **Hexad** is shown beside the 1 mV calibration bar on the ECG wave and all derived leads are marked with a "d" in front of the lead label, for example dV1.

WARNING

Hexad derived 12-lead ECGs and their measurements are approximations to conventional 12-lead ECGs. They should not be used for diagnostic interpretations.

Chest Electrode Placement

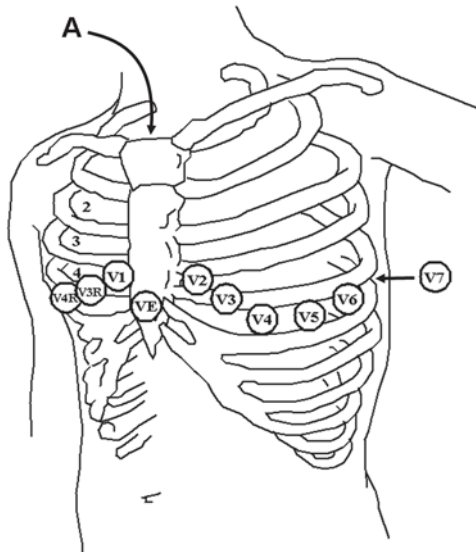

A - Angle of Louis

V1 on the fourth intercostal space at the right sternal border

V2 on the fourth intercostal space at the left sternal border

V3 midway between the V2 and V4 electrode positions

V4 on the fifth intercostal space at the left midclavicular line

V5 on the left anterior axillary line, horizontal with the V4 electrode position

V6 on the left midaxillary line, horizontal with the V4 electrode position

V3R -V6R on the right side of the chest in positions corresponding to those on the left

VE over the xiphoid process

V7 on posterior chest at the left posterior axillary line in the fifth intercostal space

V7R on posterior chest at the right posterior axillary line in the fifth intercostal space

V8 posterior lead, level with V7 at the left midscapular line

V9 posterior lead, level with V7 at the left spinal border.

For accurate chest electrode placement and measurement, it is important to locate the fourth intercostal space.

- 1 Locate the second intercostal space by first palpating the Angle of Louis (the little bony protuberance where the body of the sternum joins the manubrium). This rise in the sternum is where the second rib is attached, and the space just below this is the second intercostal space.
- 2 Palpate and count down the chest until you locate the fourth intercostal space.

Lead Placement for a 10-Electrode Cable Set

When monitoring 12 leads of ECG, using a 10-electrode lead placement, it is important to correctly place electrodes and to label all 12-lead ECG reports with the correct lead placement.

Conventional 12-Lead ECG

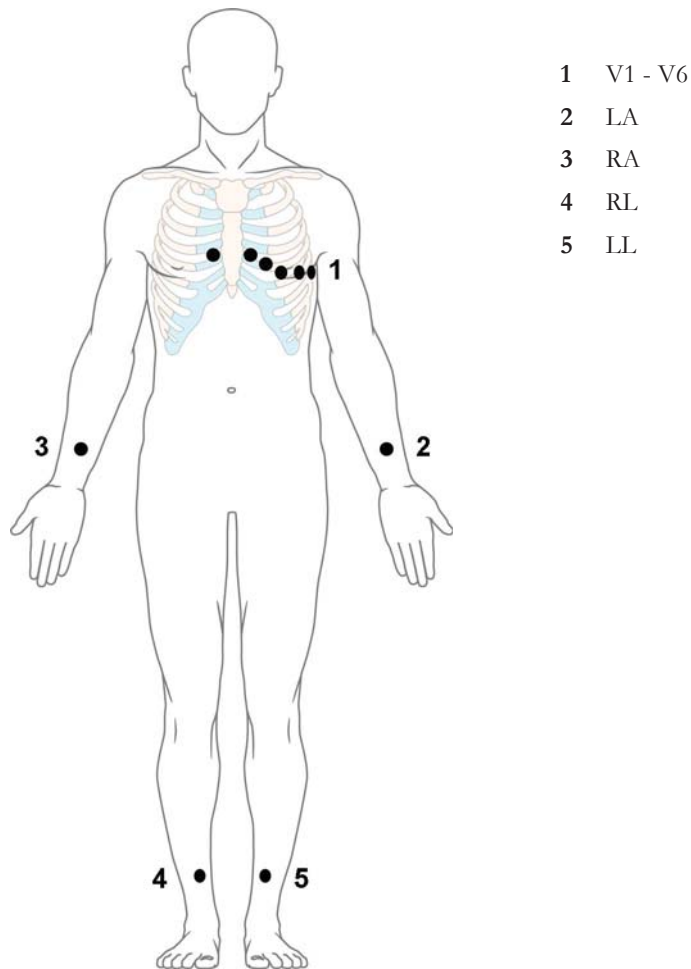

- 1 V1 - V6
- 2 LA
- 3 RA
- 4 RL
- 5 LL

In conventional 12-Lead ECG using 10 electrodes, an electrode is placed on the right arm, left arm, right leg, and left leg. Six V- electrodes are placed on the chest. The right leg electrode is the reference electrode.

Limb electrodes:

- Place arm electrodes on the inside of each arm, between the wrist and the elbow.
- Place leg electrodes inside of each calf, between the knee and the ankle.

Chest electrodes:

V1 - on the 4th intercostal space at the right sternal border

5 ECG, Arrhythmia, ST and QT Monitoring

V2 - on the 4th intercostal space at the left sternal border

V3 - midway between the V2 and V4 electrode positions

V4 - on the 5th intercostal space at the left midclavicular line

V5 - on the left anterior axillary line, horizontal with the V4 electrode position

V6 - on the left midaxillary line, horizontal with the V4 electrode position

Modified 12-Lead ECG

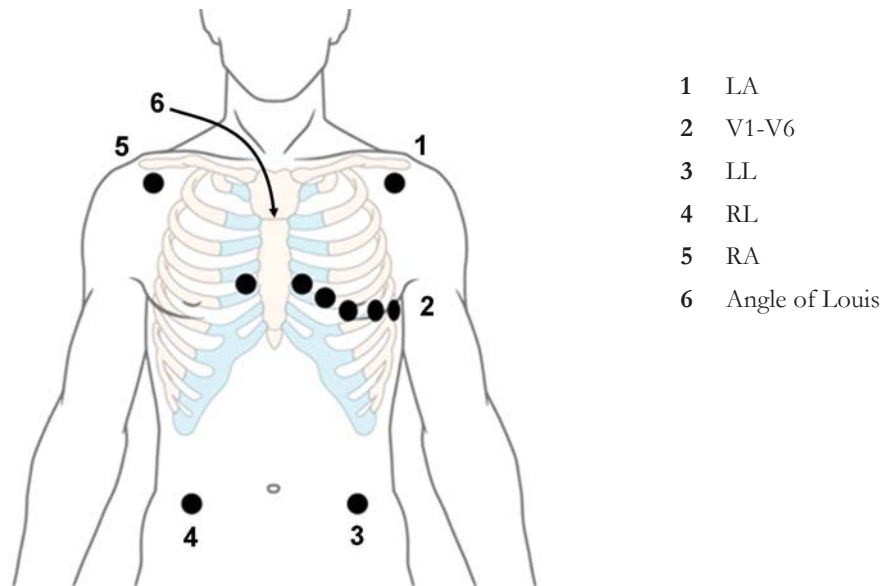

If your institution uses modified 10-lead ECG electrode placement (the Mason-Likar Lead System), place the four limb electrodes close to the shoulders and lower abdomen.

The six V electrodes are placed on the chest in the same position as the conventional 12-lead placement.

Choosing Standard or Modified Electrode Placement

If your institution uses modified 10 Lead ECG electrode placement (the Mason-Likar Lead System), you must set **Limb Leads** to **on Trunk** in the monitor. To do this,

- in the **Setup ECG** menu, select **Limb Leads** and select **on Trunk**.
 - When **Limb Leads** is set to **on Trunk**, ECG Reports A/B will be labeled **12 Lead ECG Report (Mason-Likar)**.
 - When **Limb Leads** is set to **on Limbs**, ECG Reports A/B will be labeled **12 Lead ECG Report (Standard)**.

The limb leads setting for 12-lead captures is made separately, see “Changing Settings for a Captured 12-Lead ECG” on page 161.

WARNING

Interpretations and analysis results provided by the Philips DXL 12-lead Analysis Algorithm for 12-lead ECG captures are intended for use with Standard (conventional) 12-lead placement and are not validated for use with other lead placements.

Using ECG analysis interpretation statements and measurements for 12-lead ECGs obtained using modified limb electrode placement (for example, Mason-Likar) may lead to misdiagnosis. The modified limb electrode placement does not look the same as the conventional 12-lead ECG and may mask inferior infarction due to calculated axis, R, P and T wave magnitudes shifts and ST slope.

When exporting 12-lead ECGs obtained using the Mason-Likar limb electrode placement, be aware that on non-Philips systems the Mason-Likar label will not be visible.

EASI Lead Placement for a 5-Electrode Cable Set

Using a 5-electrode set in EASI lead placement you can monitor up to 12 ECG leads simultaneously and continuously at the bedside. EASI provides a monitoring method for trending ST segment changes that can provide an early indication of ischemia.

WARNING

EASI-derived 12-lead ECGs and their measurements are approximations to conventional 12-lead ECGs. As the 12-lead ECG derived with EASI is not exactly identical to the 12-lead conventional ECG obtained from an electrocardiograph, it should not be used for diagnostic interpretations.

Respiratory monitoring is also possible with the EASI placement; respiration is measured between the I and A electrodes.

Place the electrodes as accurately as possible to obtain the best quality EASI measurements.

When EASI lead placement is selected, **EASI** is shown beside the 1 mV calibration bar on the ECG wave on the display, and **EASI** is marked on any recorder strips and printouts.

EASI Monitoring During INOP Conditions

If one of the derived EASI leads has an INOP condition (for example, **Lead Off**), a flat line is displayed. After 10 seconds, the directly acquired EASI AI, AS, or ES lead (depending on which is available) is displayed with the corresponding lead label. This causes an arrhythmia relearn.

EASI Electrode Placement

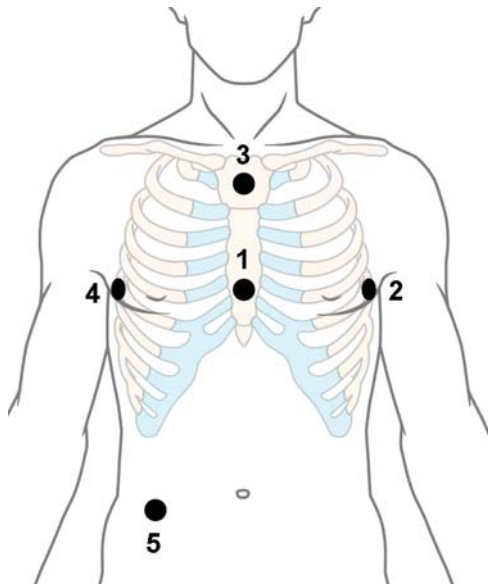

- 1 E (V) - on the lower sternum at the level of the fifth intercostal space
- 2 A (LL) - on the left midaxillary line at the same level as the E electrode
- 3 S (LA) - on the upper sternum
- 4 I (RA) - on the right midaxillary line at the same level as the E electrode
- 5 N - reference electrode - can be anywhere, usually below the sixth rib on the right hip

Capture 12-Lead

You can view a 12-Lead ECG on the screen, capture a 12-Lead ECG episode, preview the captured ECG data and then store it and send it to a connected Information Center for analysis. You can download the resulting analysis from the Information Center and also other 12-Lead captures for review at the monitor. A 12-Lead report can be printed that also includes the downloaded analysis results and an ST Map. You can operate the 12-Lead Export function and the 12-Lead Lock/Unlock function at the Information Center remotely from the monitor.

The monitor can store one 12-Lead ECG episode at any time.

Viewing the Realtime 12-Lead ECG

To open the 12-Lead ECG window and view the realtime ECG waves,

- Select the **Capture 12 Lead** SmartKey, or
- Select **Main Setup**, then **Capture 12 Lead**.

If a previously viewed 12-Lead ECG was not stored, a window will pop up asking whether you want to keep it or not. The title bar of the window shows the date and time when this 12-Lead ECG was captured. If you do not need the ECG, select **No** to discard it, otherwise, select **Yes** and then select **Store & Send** to store that 12-Lead ECG and send it to an Information Center (if one is connected).

If your patient is not admitted, you will be prompted to enter at least the age and gender of the patient. This information is needed for analysis of the 12-Lead ECG at the Information Center but is not essential if you only want to capture the 12-Lead ECG without sending it for analysis. To enter this information:

- 1 Select the **Admit Patient** pop-up key, then
- 2 Enter the information in the **Patient Demographics** window.
- 3 Open the 12-Lead ECG window again as described above.

The age and gender will now be displayed in the title bar of the pop-up keys.

To change the way the realtime waves are displayed, select the **Change View** pop-up key or select the wave area. You can switch between a one or two column display. The two column display lets you see a larger representation of the waves.

If you are using the Hexad lead placement, you can select the **Setup Leads** pop-up key to select the positions of the chest leads (Va and Vb or Ca and Cb).

While the realtime 12-Lead waves are being viewed in the window, the ECG filter mode (see “[Changing the ECG Filter Settings](#)” on page 151) is changed to the 12-Lead filter setting (see “[Changing Settings for a Captured 12-Lead ECG](#)” on page 161).

Capturing the 12-Lead ECG

To capture the last 10 seconds of ECG data, select the **Capture Waves** pop-up key. The pop-up key is active as soon as enough wave data is available; until then a progress bar is displayed in the title bar of the pop-up keys. A preview of the captured data appears on the screen (unless your monitor is connected to an Information Center with software release earlier than Revision M — then the captured data is automatically stored and sent to the Information Center).

The title bar of the pop-up keys will now show the current filter setting and, if you are using EASI or Hexad lead placement, an **EASI** or **Hexad** indicator will appear at the bottom of the captured data.

You can at any time return to the realtime 12-Lead ECG view by selecting the **Show Waves** pop-up key. From there, you return to the preview window by selecting the **Review 12 Lead** pop-up key and then selecting the 12-Lead marked with * from the list.

Changing Settings for a Captured 12-Lead ECG

Select the **Setup 12 Lead** pop-up key to choose settings for filter, gain, etc., if changes are needed. All changes apply to both the display and the printed 12-Lead report. The changes are only applied temporarily and will not be stored. If you want to change the default settings, see “[Setting Up the 12-Lead ECG](#)” on page 163.

High Pass Filter	Sets the high pass filter for the waveforms. Choices are 0.05 Hz , 0.15 Hz and 0.5 Hz .
Low Pass Filter	Sets the low pass filter for the waveforms. Choices are 40 Hz , 100 Hz and 150 Hz .
AC Filter	Switches the AC (line frequency) filter On or Off .
Gain	Defines the gain used for the waveforms. Choices are 2.5 mm/mV , 5 mm/mV , 10 mm/mV and 20 mm/mV .
Chest Gain	Defines the gain for the chest leads relative to the standard gain setting. Choices are Full and Half .
Paper Speed	Defines the waveform speed. Choices are 25 mm/sec and 50 mm/sec .
Limb Leads	Sets the position of the limb leads. Choices are on Limbs and on Trunk . Select on Trunk when using the modified 10-electrode lead placement (the Mason-Likar Lead System). Captured 12-lead ECGs will then be labeled Mason-Likar to the right of the bandwidth annotation at the Information Center.
Format	Defines the page layout. Choices are 12x1 , 6x2 , 3x4 , 3x4 1R , 3x4 3R , 3x4 ST and 3x4 1R ST . 1R and 3R refer to 1 or 3 rhythm leads, ST formats contain an ST map.
Time	Defines whether all leads show simultaneous or sequential intervals of time, when displaying or printing 2 or more columns. Choices are Sequential and Simultaneous .

Rhythm Lead 1 Rhythm Lead 2 Rhythm Lead 3	Defines which lead will be used as rhythm lead 1, 2 or 3. Choices are Primary, Secondary, I, II, III, aVR, aVL, aVF, V1, V2, V3, V4, V5, V6, V7, V8, V9, V3R, V4R, V5R, V6R, and MCL. This setting is only relevant when 3x4 1R, 3x4 1R ST or 3x4 3R is selected as Format .
Lead Sequence	Defines the sequence in which the leads are presented. Choices are Cabrera and Internat .

Storing and Sending the 12-Lead ECG

You can assign an order number that will then be associated and stored with the 12-Lead ECG.

If you have an Information Center connected, it may provide order management, in which case an **Order (xx)** pop-up key is displayed. This opens the order window from the Information Center, showing a list of any pending 12-lead orders for the patient. In this window you can assign and remove orders, in the same way as you would do directly at the Information Center.

If no Information Center is connected, you can enter an order number manually. Select the **Enter Order #** pop-up key and type in the number. The order number will be stored with the capture and displayed in the title bar of the pop-up keys.

To store the previewed data on the monitor and send it to a connected Information Center for storage and analysis, select the **Store & Send** pop-up key.

If the monitor is connected to an Information Center, use the **Store & Send** function before patient transport to store the 12-Lead ECG centrally, as the 12-Lead ECG data will not be uploaded from the Multi-Measurement Module to another monitor after transport.

If the connection to the Information Center is not active while storing, the 12-Lead ECG will be automatically sent as soon as the connection is established or restored. If a previously stored 12-Lead ECG is waiting to be sent to the Information Center, it will be overwritten when a new 12-Lead ECG is stored and can then not be sent to the Information Center.

Printing the 12-Lead ECG

Print a dedicated 12-Lead ECG report by selecting the **Print Report** pop-up key.

When you are working with a PIC iX that provides 12-Lead analysis data to the monitor, the report contains the 12-Lead analysis results as well as measurement values (e.g. ST values, QT values, HR) that are also downloaded from the PIC iX.

If you work with a PIIC, or a PIC iX without the necessary license, no 12-Lead analysis data is provided to the monitor. In this case, the report only contains the real-time measurement values from the bedside.

Consequently, the measurement values in the report might differ in the two cases, due to the slightly different algorithm approaches of the patient monitor (real-time measurement) and the PIC iX (diagnostic interpretation of 12-Lead capture).

Downloading Analysis Results (PIC iX only)

Download analysis results from the Information Center by selecting **Show Analysis**. Return to the previous screen by selecting **Hide Analysis**.

Reviewing Previewed or Stored 12-Lead Captures

To view 12-Lead captures previewed or stored on the monitor or 12-Lead captures stored at the Information Center (PIC iX only), select **Review 12 Lead**. You can then select from a list of 12-Lead captures available for the current patient.

The 12-Lead captures in the list may be marked with a symbol, for example an open or closed padlock to indicate unlocked or locked status or a * to indicate preview status.

Information Center Remote Export (PIC iX only)

Use the **Export** key to remotely start the 12-Lead export functionality of the Information Center. A list of export fields appears where you can enter corresponding information, as required.

Information Center Remote Lock/Unlock (PIC iX only)

Use the **Lock** key to remotely lock the 12-Lead capture at the Information Center. If it is already locked, the **Unlock** key will be displayed.

Capture 12-Lead Pop-up Keys

Here is a summary of all the pop-up keys available during the 12-Lead ECG procedure:

Pop-up Keys	Selecting this pop-up key lets you
Admit Patient	enter the age and gender for the patient, to allow analysis of the 12-Lead ECG.
Change View	switch between the single column and two-column display of the realtime wave data.
Capture Waves	capture the current ECG waves and open the preview window.
Show Waves	return to the realtime 12-Lead ECG view.
Setup 12 Lead	choose settings for filter, gain, display layout, etc.
Order (xx)	open the order window from the Information Center (if available) and assign order numbers to 12-Lead captures.
Enter Order #	enter an order number that is stored with the capture and displayed in the title bar of the pop-up keys.
Print Report	print a 12-Lead report.
Store & Send	store the captured 12-Lead ECG in the monitor and send it to the Information Center.
Review 12 Lead	view a list of 12-Lead captures available at the monitor or at the Information Center, and select one for review.
Show Analysis	download analysis results from the Information Center.
Export	remotely export 12-Lead ECG data from the Information Center to an ECG management system (see the Information Center Instructions for Use for details).
Lock / Unlock	remotely lock/unlock the 12-Lead capture at the Information Center.
Setup Leads	switch between Standard and EASI lead placement and select the positions of the chest leads (Va and Vb or Ca and Cb), when using Hexad lead placement.

Setting Up the 12-Lead ECG

You can make settings that will be stored and used in future as default settings for each 12-Lead ECG capture made.

- 1 Select the HR numerics on the screen to enter **Setup ECG**.
- 2 Select **12Lead**.
- 3 The **Setup 12 Lead** window opens for you to make the default settings.

For a description of the available settings, see “[Changing Settings for a Captured 12-Lead ECG](#)” on page 161.

ECG and Arrhythmia Alarm Overview

The ECG and arrhythmia alarms available depend on which measurements are switched on, and the arrhythmia option enabled for your monitor.

- Cardiotach alarms are available when HR is on and the active alarm source is ECG, but Arrhythmia is switched off
- Basic arrhythmia alarms are available when Arrhythmia is switched on
- Enhanced arrhythmia alarms are available when Arrhythmia is switched on and the Enhanced Arrhythmia option has been enabled for your monitor

Alarm	Description	Arrhythmia Configuration		
		Arrhythmia Off	Basic Arrhythmia	Enhanced Arrhythmia
*** Asystole	No beat detected for a period > the asystole threshold (2.5 to 4.0 seconds)	x	x	x
*** Vent Fib/Tach	Fibrillatory wave (sinusoidal wave between 2 - 10 Hz) for 4 consecutive seconds	x	x	x
*** VTach	A run of consecutive beats labeled as V with run length \geq the V-Tach Run limit and ventricular HR > V-Tach HR limit		x	x
*** Extreme Tachy	Heart Rate > the Extreme Tachy limit	x	x	x
*** Extreme Brady	Heart Rate < the Extreme Brady limit	x	x	x
** HR High	Heart rate > the high HR limit	x	x (see note)	x (see note)
** HR Low	Heart rate < the low HR limit	x	x (see note)	x (see note)
* Non-Sustain VT	A run of consecutive beats labeled as V with run length < the V-Tach Run Limit and ventricular HR > the V-Tach HR limit			x
* Vent Rhythm	A run of consecutive beats labeled as V with run length > the Vent rhythm limit and ventricular HR \leq the V-Tach HR limit			x
* Run PVCs High	A run of > 2 consecutive beats labeled as V with run length < Vent rhythm run limit and ventricular HR \leq V-Tach HR limit			x
* Pair PVCs	Two ventricular beats labeled as V between two beats not labeled as V			x

Alarm	Description	Arrhythmia Configuration		
		Arrhythmia Off	Basic Arrhythmia	Enhanced Arrhythmia
* R-on-T PVCs	For HR < 100, a beat labeled as V with R-R interval < 1/3 of the average R-R interval followed by a compensatory pause > 1.25 times the average R-R interval or 2 such beats labeled as V without a compensatory pause occurring within 5 minutes of each other (Note: When HR > 100, 1/3 of the R-R interval is too short for detection)			x
* Vent Bigeminy	A dominant rhythm of beats labeled as N, V, N, V, N			x
* Vent Trigeminy	A dominant rhythm of beats labeled as N, N, V, N, N, V, N, N			x
* PVCs/min High	Within 1 minute, the number of beats labeled as V > the PVCs/min limit		x	x
* Multiform PVCs	The occurrence of two differently shaped beats labeled as V within the last 60 beats and each occurring at least twice within the last 300 beats			x
* Pause	No beat detected for a period > the pause alarm threshold (1.5 to 2.5 seconds)			x
* Missed Beat	No beat detected for a period > 1.75 times the average R-R interval for HR < 120, or no beat detected for > 1 second with HR > 120 (Paced mode off)			x
* Pacer Not Capt	No beat detected for a period > 1.75 times the average R-R interval and pace pulse(s) detected. (Paced mode on)		x	x
* Pacer Not Pacing	No beat detected for a period > 1.75 times the average R-R interval and no pace pulse(s) detected (Paced mode on)		x	x
* SVT	A run of consecutive beats labeled as S with run length \geq SVT run limit and ventricular HR > SVT HR limit			x
* HR High	Heart rate > the high HR limit		x (see note)	x (see note)
* HR Low	Heart rate < the low HR limit		x (see note)	x (see note)
* AFIB	An irregular rhythm of beats labeled as N and variability in P-R intervals and P-wave variability (For adult patient category only)			x
* End AFIB	Atrial Fibrillation no longer detected for the Afib end delay time (For adult patient category only)			x

Alarm	Description	Arrhythmia Configuration		
		Arrhythmia Off	Basic Arrhythmia	Enhanced Arrhythmia
* Irregular HR	An irregular rhythm of beats labeled as N (irregular R-R intervals changes greater than 12.5%)			x
* End Irregular HR	Irregular HR rhythm no longer detected for the irregular HR end delay time			x

Note: ** HR Low and ** HR High are available only if HR alarms are configured as yellow alarms, and * HR Low and * HR High are available only if HR alarms are configured as short yellow alarms.

Using ECG Alarms

ECG alarms can be switched on and off and the high and low alarm limits changed just like other measurement alarms, as described in the “Alarms” chapter. Special alarm features which apply only to ECG are described here.

Extreme Alarm Limits for Heart Rate

The extreme rate alarms, extreme tachycardia and extreme bradycardia, are generated by the active alarm source, either HR or Pulse.

The difference between the low HR alarm limit and the extreme bradycardia limit is unit configured. For example, if the low alarm limit is 60 bpm and the extreme bradycardia limit difference is configured to be 20 bpm, then the extreme bradycardia limit is 40 bpm. If the difference is configured to be 0, there will always be an extreme bradycardia alarm when the HR falls below the HR low limit.

The same is true for the difference between the high HR alarm limit and the extreme tachycardia limit. In the same way, the extreme tachycardia limit is determined by adding a difference to the high HR limit.

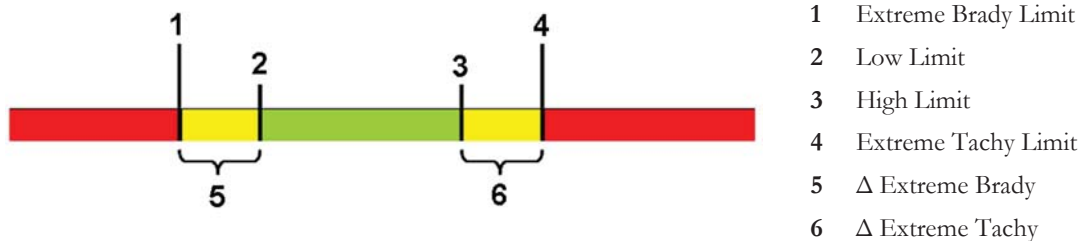

The difference is set in Configuration Mode. You need to know which value has been configured for your monitor. To see the difference value for the extreme rate alarms on your monitor, in the **Setup ECG** menu, see the menu items **Δ ExtrTachy** and **Δ ExtrBrady**.

For safety, the extreme bradycardia and extreme tachycardia limits clamp at a configured value. For example, the extreme bradycardia limit for neonates has a default limit clamp at 70 bpm. Thus if the HR low alarm limit is moved to 80 bpm and the extreme bradycardia limit difference is 20 bpm, the extreme bradycardia limit will be 70 bpm. However, if you move the HR low alarm limit below the clamp to 65 bpm, the extreme bradycardia limit will also be 65 bpm and only the extreme bradycardia alarm will occur if the HR falls below this limit.

You can view the current limits for the extreme rate alarms, Extreme Tachy and Extreme Brady, in the measurement's alarm limits window:

- 1 Select one of the alarm fields.
- 2 Select the **Alarm Limits** pop-up key.
- 3 Select **HR**.

The alarm limit window for HR is shown, with the high and low limits and the Extreme Tachy and Extreme Brady limits.

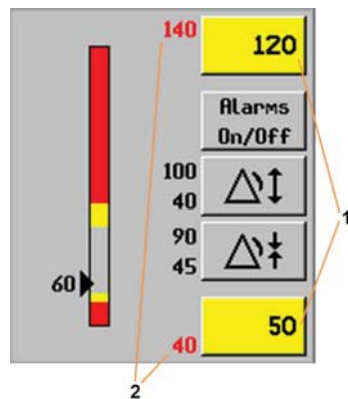

- 1 High and low alarm limits
- 2 Extreme Tachy and Extreme Brady limits

ECG Alarms Off Disabled

Be aware that your hospital department may have decided to disable the **Alarms Off** setting for ECG in the monitor's Configuration Mode. In this case, HR alarms cannot be switched off in Monitoring Mode. If you try to switch off the HR alarms, you will see the message **To activate enter Config and enable Alarms Off**.

HR Alarms When Arrhythmia Analysis is Switched Off

When arrhythmia analysis is switched off, only these HR-related alarms will be detected:

- the asystole alarm
- the ventricular fibrillation/tachycardia alarm
- the extreme tachycardia and extreme bradycardia alarms
- the high heart rate and low heart rate alarms.

Enhanced Asystole Detection

In order to improve alarming on asystole under certain conditions, you can set **Asystole Detect.** in Configuration Mode to **Enhanced**. In enhanced mode an asystole alarm will be suppressed for up to five seconds if a valid beat-to-beat Pulse is detected from an arterial Pressure.

ECG Safety Information

CAUTION

Interference from instruments near the patient and ESU interference can cause problems with the ECG wave. See the monitor specifications for more information.

WARNING

Defibrillation and Electrosurgery:

Do not touch the patient, or table, or instruments, during defibrillation.

After defibrillation, the screen display recovers within 10 seconds if the correct electrodes are used and applied in accordance with the manufacturer's instructions.

ECG cables can be damaged when connected to a patient during defibrillation. Check cables for functionality before using them again.

According to AAMI specifications the peak of the synchronized defibrillator discharge should be delivered within 60 ms of the peak of the R wave. The signal at the ECG output on the IntelliVue patient monitors is delayed by a maximum of 30 ms. Your biomedical engineer should verify that your ECG/Defibrillator combination does not exceed the recommended maximum delay of 60 ms.

When using electrosurgical (ES) equipment, never place ECG electrodes near the grounding plate of the ES device, as this can cause a lot of interference on the ECG signal.

General:

When you are connecting the electrodes or the patient cable, make sure that the connectors never come into contact with other conductive parts, or with earth. In particular, make sure that all of the ECG electrodes are attached to the patient, to prevent them from contacting conductive parts or earth.

During surgery:

Use the appropriate orange ECG OR trunk cable, **or** ECG OR electrode cable set with an orange connector, for measuring ECG in the operating room. These cables have extra circuitry to protect the patient from burns during cautery, and they decrease electrical interference. This also reduces the hazard of burns in case of a defective neutral electrode at the HF device. **Do not use** the OR trunk cable and the OR electrode cable set together. Only one orange-coded part must be used for the additional protection.

These cables cannot be used for measuring respiration.

Pacemaker failure:

During complete heart block or pacemaker failure to pace/capture, tall P-waves (greater than 1/5 of the average R-wave height) may be erroneously counted by the monitor, resulting in missed detection of cardiac arrest.

Patients exhibiting intrinsic rhythm:

When monitoring paced patients who exhibit only intrinsic rhythm, the monitor may erroneously count pace pulses as QRS complexes when the algorithm first encounters them, resulting in missed detection of cardiac arrest.

The risk of missing cardiac arrest may be reduced by monitoring these patients with low heart rate limit at or slightly above the basic/demand pacemaker rate. A low heart rate alarm alerts you when the patient's heart rate drops to a level where pacing is needed. Proper detection and classification of the paced rhythm can then be determined.

Filtered ECG signal from external instruments:

Instruments such as defibrillators or telemetry units produce a filtered ECG signal. When this signal is used as an input to the bedside monitor, it is filtered again. If this twice-filtered signal is passed to the arrhythmia algorithm, it may cause the algorithm to fail to detect pace pulses, thus compromising paced patient monitoring performance.

External pacing electrodes:

When an external transcutaneous pacemaker is being used on a patient, arrhythmia monitoring is severely compromised due to the high energy level in the pacer pulse. This may result in the arrhythmia algorithm's failure to detect pacemaker noncapture or asystole.

Fusion beat pacemakers:

Pacemakers can create fusion beats, which occur when an intrinsically conducted beat and a paced beat occur simultaneously, that may not be detected by the monitor's QRS detector.

Rate adaptive pacemakers:

Implanted pacemakers which can adapt to the Minute Ventilation rate may occasionally react on the Impedance measurement used by patient monitors for the determination of the Resp value and execute pacing with the maximum programmed rate. Switching off the Resp measurement can prevent this.

Line isolation monitor transients:

When electrodes or lead wires are loose or detached, the monitor becomes susceptible to switching transients from some types of line isolation monitors. Line isolation monitor transients may resemble actual cardiac waveforms and thus inhibit heart rate alarms. To minimize the chance of this occurring, always adhere to the instructions for skin preparation and electrode placement given in this chapter.

About Arrhythmia Monitoring

Arrhythmia analysis provides information on your patient's condition, including heart rate, PVC rate, rhythm, and ectopics. The monitor uses the user-selected primary and secondary ECG leads for single-lead or multi-lead arrhythmia analysis. During arrhythmia analysis, the monitor continuously:

- optimizes ECG signal quality. This is important for arrhythmia analysis. The monitor continuously filters the ECG signal to remove baseline wander, muscle artifact, and signal irregularities. Also, if the Patient Paced status is set to **Yes**, pace pulses are filtered out to avoid processing them as QRS beats.
- detects beats, for example, QRS complexes, identifying them for further analysis.
- measures signal features such as R-wave height, width, and timing.
- creates beat templates, and classifies and labels beats to aid in rhythm analysis and alarm detection.
- examines the ECG signal for ventricular fibrillation, asystole, and noise.

Arrhythmia Options

Your monitor has either the basic or the enhanced arrhythmia option. Both options provide rhythm and ectopic status messages and beat labeling. The number of rhythms being classified, events being detected, and alarms generated differs according to the option. The alarms available with the different options are listed in the section “[ECG and Arrhythmia Alarm Overview](#)” on page 164, the rhythm and ectopic messages detected are listed in “[Arrhythmia Status Messages](#)” on page 172.

Where Can I Find More Information?

See the Application Notes on ST and Arrhythmia supplied on your documentation DVD for detailed information on the arrhythmia algorithm and its clinical application.

Switching Arrhythmia Analysis On and Off

- 1 In the **Setup Arrhy** menu, select **Arrhythmia** to switch between **On** and **Cardiotach**.
- 2 Select the **Confirm** pop-up key which appears at the bottom of the screen.

Be aware that when arrhythmia analysis is switched to **Cardiotach** mode,

- the message **Cardiotach Mode** appears beside the ECG wave, if configured to do so
- only the HR-related alarms are detected (the asystole alarm, the ventricular fibrillation/tachycardia alarm, the extreme tachycardia and extreme bradycardia alarms, the high heart rate and low heart rate alarms)
- HR High and HR Low alarms behave like normal yellow alarms, no timeout periods are active.

Choosing an ECG Lead for Arrhythmia Monitoring

It is important to select a suitable lead for arrhythmia monitoring.

Guidelines for non-paced patients are:

- QRS complex should be tall and narrow (recommended amplitude > 0.5 mV)
- R-Wave should be above or below the baseline (but not biphasic)
- T-wave should be smaller than 1/3 R-wave height
- the P-wave should be smaller than 1/5 R-wave height.

For paced patients, in addition to the above, the pace pulse should be:

- not wider than the normal QRS
- the QRS complexes should be at least twice the height of pace pulses
- large enough to be detected, with no repolarization.

To prevent detection of P-waves or baseline noises as QRS complexes, the minimum detection level for QRS complexes is set at 0.15 mV, according to IEC 60601-2-27 and AAMI-EC 13 specifications. Adjusting the ECG wave size on the monitor display (gain adjustment) does not affect the ECG signal which is used for arrhythmia analysis. If the ECG signal is too small, you may get false alarms for pause or asystole.

Atrial Fibrillation Alarm

The monitor performs atrial fibrillation analysis using information about the R-R irregularity, P-R interval variability and P wave variability.

In order to generate an Afib alarm the following criteria must be detected for 1 minute:

- normal beat R-R intervals must be irregular
- P-R interval deviation must be large
- P-wave region must not match well

Atrial fibrillation analysis is only available for adult patients and atrial fibrillation detection cannot be performed on PVCs or Paced beats.

An *** End AFIB** alarm will occur when no atrial fibrillation waveform was detected for a configured delay time.

Since most atrial flutters have regular R-R intervals, they cannot be detected by the atrial fibrillation algorithm.

An *** AFIB** can be falsely detected in the presence of:

- sinus arrhythmia,
- muscle noise, or
- electrode motion artifact.

If you also have monitors with earlier software revisions, the *** AFIB** and *** End AFIB** alarms will not be generated after a transfer to one of these monitors. Always leave the Irregular HR alarm switched on, so that this alarm can be generated in such situations.

See the Application Note on Arrhythmia/ST supplied on your documentation DVD for detailed information on the arrhythmia algorithm and ECG analysis.

Aberrantly-Conducted Beats

As P-waves are not analyzed, it is difficult and sometimes impossible for the monitor to distinguish between an aberrantly-conducted supraventricular beat and a ventricular beat. If the aberrant beat resembles a ventricular beat, it is classified as ventricular. You should always select a lead where the aberrantly-

conducted beats have an R-wave that is as narrow as possible to minimize incorrect calls. Ventricular beats should look different from these 'normal beats'. Instead of trying to select two leads with a narrow R-wave, it may be easier to just select one lead and use single lead arrhythmia monitoring. Extra vigilance is required by the clinician for this type of patient.

Intermittent Bundle Branch Block

Bundle branch and the other fascicular blocks create a challenge for the arrhythmia algorithm. If the QRS during the block changes considerably from the learned normal, the blocked beat may be incorrectly classified as ventricular, causing false PVC alarms. You should always select a lead where the bundle branch block beats have an R-wave that is as narrow as possible to minimize incorrect calls. Ventricular beats should look different from these 'normal beats'. Instead of trying to select two leads with a narrow R-wave, it may be easier to just select one lead and use single lead arrhythmia monitoring. Extra vigilance is required by the clinician for this type of patient.

Understanding the Arrhythmia Display

Your monitor screen may look slightly different from the illustration.



- 1 Pace pulse marks
- 2 Beat label
- 3 HR Numeric
- 4 PVC Numeric
- 5 Ectopic status message
- 6 Rhythm status message
- 7 Delayed arrhythmia wave

Viewing Arrhythmia Waves

To review arrhythmia beat labels, in the **Setup Arrhy** menu, select **Annotate Arrhy**.

The wave showing the primary ECG lead will be delayed by six seconds and shown on a gray background. Beat labels will be annotated above the ECG wave and **Delayed** will be written beside it.

To return to the normal ECG primary lead display, select **Annotate Arrhy** again.

Arrhythmia Beat Labels

Arrhythmia beat labels tell you how the monitor is classifying beats.

Beat Label	Beat Classification
N ¹	Normal
V ¹	Ventricular Ectopic
S ¹	Supra-ventricular Premature
P ¹	Paced
'	Pacer Spike
"	Biventricular Pacer Spike

Beat Label	Beat Classification
L	Learning patient's ECG
A	Artifact (noisy episode)
?	Insufficient information to classify beats
I	Inoperative condition (e.g., Leads Off)
M	Pause or missed beat

¹ In Cardiotach Mode these beats are labeled **B**.

Arrhythmia Status Messages

The monitor displays two types of status messages:

- Rhythm Status Messages -- to indicate the patient's rhythm.
- Ectopic Status Messages -- to indicate the presence of ectopic beats.

These status messages are shown on the right hand side of the primary ECG wave. They are updated every second, with the exception of the Sinus and Supraventricular (SV) rhythm messages.

The Sinus and SV rhythm messages are updated based on the current heart rate, taking into account the patient category (adult, pediatric, or neonatal). For the message to change from one rhythm status to another, the HR must be in the new range for five beats.

If you have basic arrhythmia capability, you will get only messages for the alarms provided with this level.

Rhythm Status Messages

The label B or E indicates basic (B) or enhanced (E) arrhythmia capability.

Rhythm Status Message	Description	B or E
Asystole	No beat detected for a period > the asystole threshold (2.5 - 4.0 seconds)	B, E
Vent Fib/Tach	Fibrillatory wave (sinusoidal wave between 2 - 10 Hz) for 4 consecutive seconds	B, E
VTach	A run of consecutive beats labeled as V with run length \geq the V-Tach Run limit and ventricular HR > V-Tach HR limit	B, E
Sustained VT	Ventricular tachycardia rhythm for more than 15 seconds	E
Vent Rhythm	A run of consecutive beats labeled as V with run length > the Vent rhythm limit and ventricular HR \leq the V-Tach HR limit	E
Vent Bigeminy	A dominant rhythm of beats labeled as N, V, N, V, N	E
Vent Trigeminy	A dominant rhythm of beats labeled as N, N, V, N, N, V, N, N	E
Paced Rhythm	A dominant rhythm of beats labeled as P	B, E
Irregular HR	Consistently irregular rhythm	E
Sinus Brady Sinus Rhythm Sinus Tach	A dominant rhythm of beats labeled as N or S preceded by P-waves	B, E
SV Brady SV Rhythm SV Tach	A dominant rhythm of beats labeled as N or S not preceded by P-waves	B, E
Unknown ECG Rhythm	Rhythm cannot be determined	B, E

Rhythm Status Message	Description	B or E
Learning ECG	Algorithm is learning the ECG beat morphology	B, E
Learning Rhythm	Algorithm is learning the rhythm of the classified beats	B, E
Cannot Analyze ECG	ECG signal is predominantly invalid or too noisy and therefore cannot be analyzed	B, E

Ectopic Status Messages

The label B or E indicates basic (B) or enhanced (E) arrhythmia capability.

Ectopic Status Message	Explanation	B or E
(No message displayed)	No ectopic activity within the last minute	
Run PVCs	More than 2 consecutive beats labeled as V within the last minute	E
Pair PVCs	Two beats labeled as V between two beats not labeled as V	E
Pacer Not Capt	No beat detected for a period > 1.75 times the average R-R interval and pace pulse(s) detected. (Paced mode on)	B, E
PacerNotPacing	No beat detected for a period > 1.75 times the average R-R interval and no pace pulse(s) detected (Paced mode on)	B, E
Pause	No beat detected for a period > 1.75 times the average R-R interval for HR <120, or No beat for 1 second with HR >120 (non-paced patient only), or No beat detected for more than the set pause threshold.	E
R-on-T PVCs	R-ON-T detected within the last minute	E
Multiform PVCs	Within the last minute, the occurrence of two differently shaped beats labeled as V within the last 60 beats and each occurring at least twice within the last 300 beats	E
Frequent SVPBs	Count of beats labeled as S within last minute is greater than 5	E
SVPBs	1-5 beats labeled as S in the last minute	E
SV Beats	Count of beats labeled as N or S within last minute and rhythm status is paced	B, E
Paced Beats	Count of beats labeled as P within last minute and rhythm status is not paced	B, E

Arrhythmia Relearning

During a learning phase:

- Alarm timeout periods are cleared
- Stored arrhythmia templates are cleared
- Asystole, Vfib, and HR alarms (when there are enough beats to compute the HR) are active. No other alarms are active.

Initiating Arrhythmia Relearning Manually

To initiate relearning manually, in the **Setup Arrhy** menu, select **Relearn Arrhy**.

- While the monitor is learning, the delayed arrhythmia wave displays the beat label **L** and the rhythm status message **Learning ECG**.
- Next, the monitor determines the dominant rhythm. The beats are labeled **N**, and the rhythm status message changes to **Learning Rhythm**.

After relearning is complete, you should check the delayed arrhythmia wave to ensure that the algorithm is labeling the beats correctly.

If beats are still not classified correctly, check that the ECG is optimized for arrhythmia monitoring. You may need to select a different lead or change the electrodes or electrode positions if there is excessive noise, unstable voltage, low amplitude, or large P- or T-waves.

Automatic Arrhythmia Relearn

Arrhythmia relearning is initiated automatically whenever:

- ECG monitoring is switched on
- The ECG Lead or Lead Label of the primary/secondary lead is changed manually, or when fallback occurs
- A Leads Off INOP condition (that has been active for > 60 seconds) ends.

If you are monitoring multi-lead arrhythmia and there is a change in one lead only, relearning happens only in the affected lead. During this learning phase, the system will continue monitoring using the other lead.

Therefore, the delayed arrhythmia wave is not labeled **L** and there is no **Learning ECG** rhythm status message. In addition, alarm timeout periods are maintained, stored arrhythmia templates are maintained for the operative lead, and all alarms switched on are active.

Arrhythmia Relearn and Lead Fallback

Lead fallback triggers an automatic arrhythmia relearn.

WARNING

If arrhythmia learning takes place during ventricular rhythm, the ectopics may be incorrectly learned as the normal QRS complex. This may result in missed detection of subsequent events of V-Tach and V-Fib.

For this reason you should:

- take care to initiate arrhythmia relearning only during periods of predominantly normal rhythm and when the ECG signal is relatively noise-free
 - be aware that arrhythmia relearning can happen automatically
 - respond to any INOP messages (for example, if you are prompted to reconnect electrodes)
 - be aware that a disconnected EASI electrode triggers an arrhythmia relearn on all leads
 - always ensure that the arrhythmia algorithm is labeling beats correctly.
-

Arrhythmia Alarms

Arrhythmia alarms can be switched on and off and the alarm settings changed just like other measurement alarms, as described in the Alarms section. Special alarm features which apply only to arrhythmia are described here.

The different alarms detected and generated by the monitor depend on the level of arrhythmia analysis that is enabled. For a complete list of arrhythmia alarms and INOPs, see the “[Alarms](#)” chapter.

The monitor detects arrhythmia alarm conditions by comparing ECG data to a set of pre-defined criteria. An alarm can be triggered by a rate exceeding a threshold (for example, HR >xx), an abnormal rhythm (for example, Ventricular Bigeminy), or an ectopic event (for example, Pair PVCs).

Yellow Arrhythmia Alarms

Yellow arrhythmia alarms are short yellow alarms specific to arrhythmia-related patient conditions. The heart rate alarms (High HR and Low HR) can be configured as short yellow or standard yellow alarms. When they are standard yellow alarms they exist independently of the other arrhythmia alarms and no timeout periods apply.

WARNING

When arrhythmia analysis is on, all yellow ECG and arrhythmia alarms are short yellow alarms (one-star). This means that the yellow alarm lamp and the tones are active for six seconds only, after which the blinking numeric and the alarm message remain for up to three minutes. The only exception to this are the HR High and Low alarms which can be configured as standard yellow alarms. Red alarms behave as usual.

Arrhythmia Alarms and Latching

When using arrhythmia analysis, **Visual Latching** and **Audible Latching** should be on for red alarms. Because of the transient nature of arrhythmia alarms, many arrhythmia conditions may go unnoticed if alarm latching is off. This setting can only be changed in Configuration Mode.

Switching Individual Arrhythmia Alarms On and Off

Some arrhythmia alarms can be individually switched on or off:

Non-Sustain, Vent Rhythm, Run PVCs, Pair PVCs, R-on-T PVCs, V.Bigeminy, V.Trigeminy, Multif.PVCs, Pacer n.Cap, Pacer n.Pac, Pause, SVT, IrregularHR, Missed Beat, PVCs/min and Afib.

To switch individual alarms on or off, in the **Setup Arrhy** menu, select the alarm from the list to switch between **On** and **Off**. Depending on your configuration, some alarms may not be available in the list and cannot be switched on or off here.

The monitor displays the INOP message **Some ECG AlarmsOff**, if configured, when more alarms are switched off than configured in your active profile.

Switching All Yellow Arrhythmia Alarms On or Off

All yellow arrhythmia alarms can be switched on and off together. To do this,

- In the **Setup Arrhy** menu, select **All Yellow Off** or **All Yellow On**.

Adjusting the Arrhythmia Alarm Limits

Some arrhythmia alarms have limits which can be individually adjusted:

VTach HR, VTach Run, PVCs/min, Vent Rhythm, SVT HR, SVT Run, Asystole Thresh., Pause Threshold, Afib/IHR End Dly.

- 1 To adjust alarm limits, in the **Setup Arrhy** menu, select the alarm to be adjusted.
- 2 Select the appropriate setting from the pop-up list.

Arrhythmia Alarm Timeout Periods

Normally, an arrhythmia alarm is announced when an alarm condition is detected. However, there are certain situations that can inhibit the audible and visible indications of the alarm even though the alarm condition was detected. These include:

- if a more serious alarm condition is active in the same chain
- if a timeout period is in effect for a particular alarm
- if a timeout period is in effect for a higher alarm in that chain.

See “[Arrhythmia Alarm Chaining](#)” on page 177 for more details on alarm chains.

What is a Timeout Period?

Timeout periods are automatically started when a yellow arrhythmia alarm is detected. During this period, the same alarm condition will not generate another alarm. Alarm conditions further down the same arrhythmia alarm chain will also not generate an alarm, but alarms further up the chain will: see “[Arrhythmia Alarm Chaining](#)” on page 177.

To view the timeout period configured for your monitor, in the **Setup Arrhy** menu, see the menu items **TimeOut 1st** and **TimeOut 2nd**.

This setting can only be changed in Configuration Mode.

**** AFIB** and **** Irregular HR** alarms do not have a timeout period. These alarms can be generated immediately after the corresponding end alarm was generated.

When **** HR High** and **** HR Low** alarms are configured as standard yellow alarms, they do not have a timeout period.

Resetting the Timeout Period

To reset the timeout period, either

- select the **Alarms Off** or **Pause Alarms** permanent key and then reselect it, or
- select **Reset Alarming** in the **Review Alarms** window or the **Alarm Messages** window.

How are Yellow Arrhythmia Alarms Indicated?

When a yellow arrhythmia alarm is generated, it triggers visual and audible indicators. Yellow arrhythmia alarms are always set to latch visually for three minutes except HR High/Low alarms, if configured to standard yellow. Depending on the alarm condition, audible and visual alarm indicators will appear as follows:

Alarm Condition	Example	Short yellow alarm tone sounds	Alarm message displayed
Single alarm instance	Non-Sustained V-tach	when alarm condition is initially detected	for 3 minutes (latching time)
Continuous alarm condition	PVCs/min HIGH	when alarm condition is initially detected and - as an alarm reminder - every time the configured timeout period has expired	until the alarm condition stops, plus a maximum of three minutes latching time
Same intermittent alarm condition	Pair of PVCs	each time the alarm condition is detected, provided that the configured timeout period has expired	

If you acknowledge a yellow arrhythmia alarm and the alarm condition still exists, the visual indicators continue until the condition stops. You will get an alarm reminder every time the configured timeout period has expired.

If you acknowledge a yellow arrhythmia alarm and the alarm condition has stopped, the visual indicators are immediately cleared. Acknowledging an alarm does not reset its timeout period, so you will not get a realarm for the same condition or lower on the chain until the timeout expires.

Arrhythmia Alarm Chaining

When arrhythmia analysis is switched on, multiple alarm conditions may be present. Announcing all of the detected alarm conditions would be confusing, and might hide a more serious condition. For this reason, the arrhythmia system sets alarm priorities through an alarm chaining system.

Only the highest priority alarm condition in each chain is announced. Lower priority alarms in the same chain will not be announced while an alarm is active or during the configured timeout period. If alarm conditions of equal severity from different chains are detected, the alarm condition that occurred most recently is announced.

See [“ECG and Arrhythmia Alarm Overview”](#) on page 164 for information on which alarms are included in the different arrhythmia options. See [“Arrhythmia Alarm Timeout Periods”](#) on page 176 for an explanation of how alarm timeouts work.

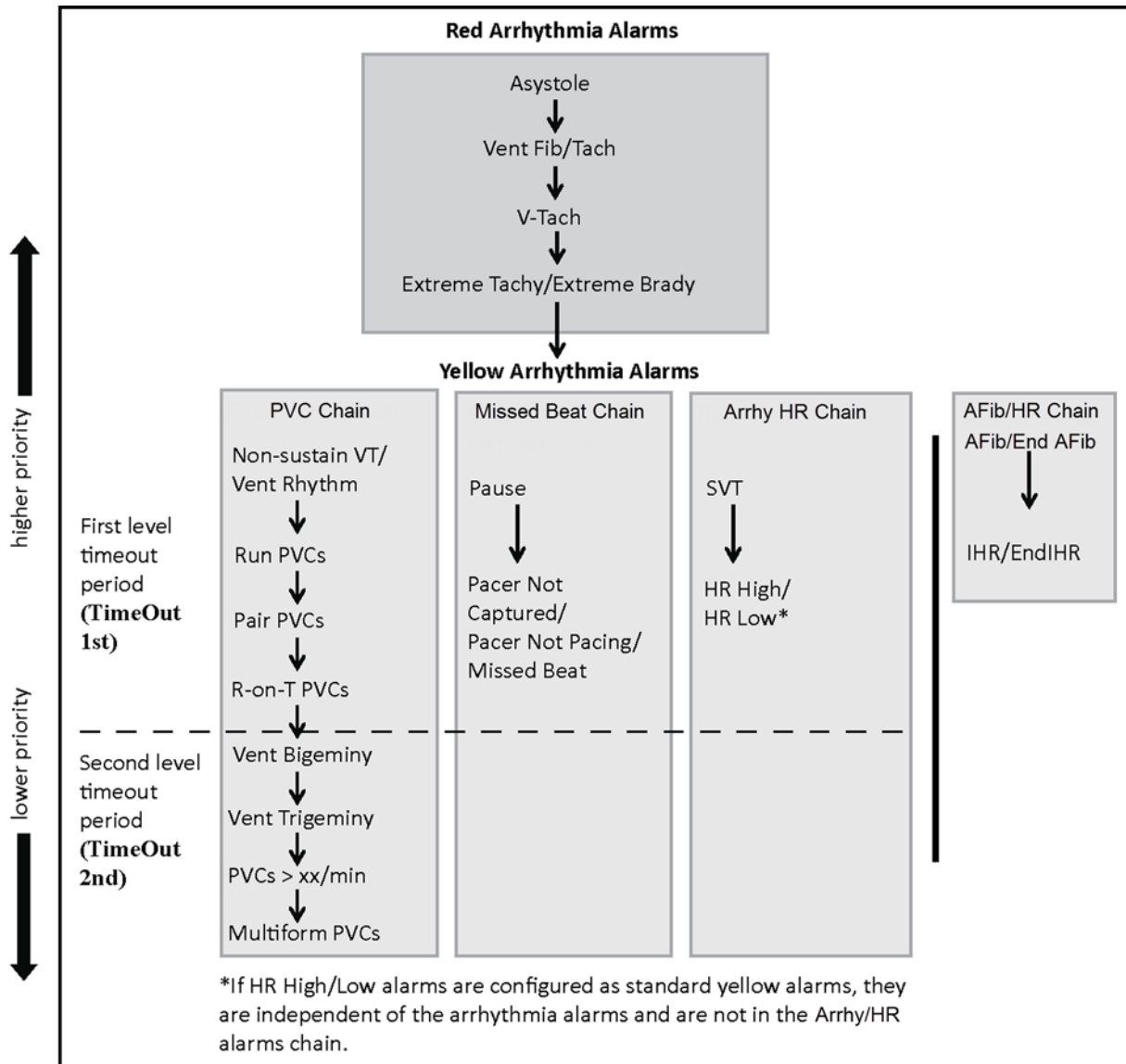

Examples of Alarm Chaining Logic

- If there is an active Vent Bigeminy alarm, a PVCs > xx/min will not be triggered because it is lower on the same chain. However, a high HR alarm will become active because it is on a different chain.
- Higher priority alarms supersede previous alarms. For example, if a Vent Trigeminy alarm is active and a Pair PVCs occurs, the Pair alarm will be activated.

Understanding PVC-Related Alarms

PVC-related alarms are detected on the basis of the current ventricular heart rate and the number of consecutive PVCs counted (referred to as PVC Runs).

As an example, this diagram illustrates the conditions under which PVC alarms would be generated if the Vent Rhythm Run limit is set to 11, the V-Tach Run Limit is set to 8, and the V-Tach HR Limit is set to 100.

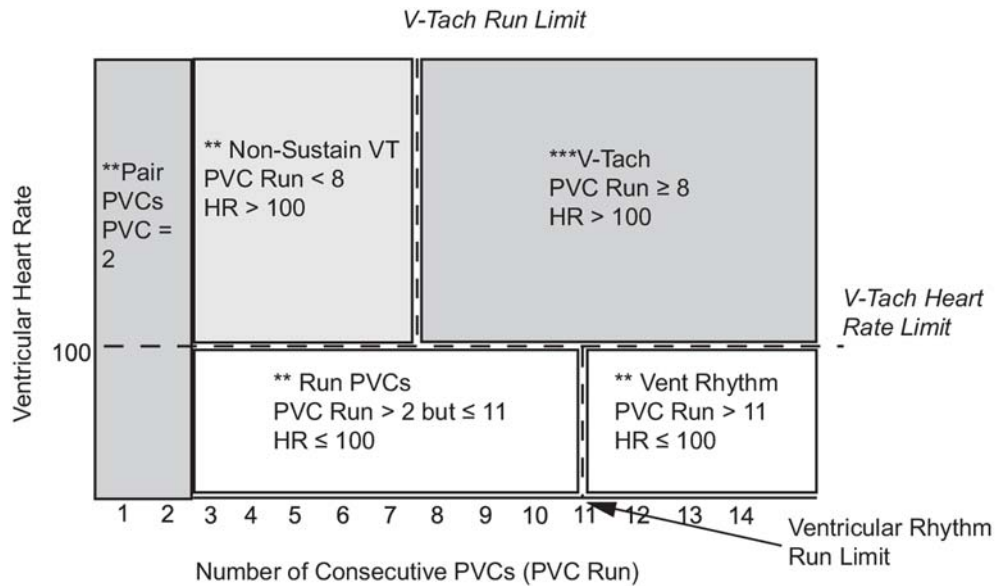

You will see that

- if both the V-Tach Heart Rate Limit and the V-Tach Run Limit are exceeded, a red V-Tach alarm is generated
- if the ventricular heart rate exceeds the V-Tach Heart Rate Limit but not the V-Tach Run Limit, a yellow Non-Sustain VT alarm is generated.

About ST Monitoring

The monitor performs ST segment analysis on normal and atrially paced beats and calculates ST segment elevations and depressions. This information can be displayed in the form of ST numerics and snippets on the monitor.

The monitor also performs ST Elevation (STE) analysis using automated ISO and J point determination and measuring the ST segment directly at the J point (J +0). This is based on the recommendations for measuring ST Elevation published by the American Heart Association, the American College of Cardiology and the European Society of Cardiology.

All available leads can be monitored continuously. The ECG waveform does not need to be displayed on the monitor for ST Segment analysis.

ST analysis is always performed using a dedicated filter which ensures diagnostic quality. If you are monitoring ECG using an ECG filter mode other than Diagnostic, the ST segment of the ECG wave may look different from the ST segment of the ST snippet for the same wave. For diagnostic evaluation of the ST segment, always switch to Diagnostic filter mode or use the ST snippet.

WARNING

Some clinical conditions may make it difficult to achieve reliable ST monitoring, for example:

- if you are unable to get a lead that is not noisy
- if arrhythmias such as atrial fib/flutter are present, which may cause an irregular baseline
- if the patient is continuously ventricularly paced
- if the patient has left bundle branch block.

You should consider switching ST monitoring off if these conditions are present.

The ST algorithm has been tested for accuracy of the ST level change information for adult patients. The clinical significance of the ST level change information should be determined by a physician.

ST segment monitoring is intended for use with adult patients only and is not clinically validated for use with neonatal and pediatric patients. For this reason, the recommended - and default - setting for ST monitoring in neonatal and pediatric modes is **ST Analysis: Off**.

Switching ST or STE On and Off

ST and STE analysis can be switched on and off independently.

To switch all ST monitoring on or off, in the **Setup ST Analysis** menu, select **ST Analysis** to switch between **On** and **Off**.

To switch all STE monitoring on or off, in the **Setup ST Elevation** menu, select **STE** to switch between **On** and **Off**.

Selecting Leads for ST Analysis

You select which leads to use for ST analysis in the **Setup ST Analysis** menu.

To see the current list of leads selected for ST analysis:

- 1 Enter the **Setup ST Analysis** menu.
- 2 Select **Setup ST Leads**. This opens the **Setup ST Leads** pop-up window. Leads chosen for ST monitoring are listed here. There are two pop-up keys at the bottom of the screen, **Add** and **Delete**. If all leads are already selected, the **Add** pop-up key is disabled.

To choose a lead for ST monitoring:

- 1 Select the **Add** key at the bottom of the **Setup ST Leads** window. This opens the **Choices** pop-up window.
- 2 Choose a lead from the list for ST monitoring. This closes the **Choices** window and adds the selected lead to the list of chosen leads.

To disable ST monitoring for a lead:

- 1 Choose a lead from the list in the **Setup ST Leads** window.
- 2 Select the **Delete** key. This removes this lead from the list.

NOTE

The order in which ST leads are listed in the **Setup ST Leads** menu determines the order in which ST leads are displayed on the monitor screen.

To change the order in which ST leads are displayed,

- 1 In the **Setup ST Leads** menu, choose a lead from the list.
- 2 Select the **Sort Up** or **Sort Down** key to move the lead up or down in the list.

Understanding the ST Display

Your monitor screen may be configured to look slightly different from the illustrations.



ST Numerics

Up to 12 ST numerics plus the ST index can be displayed on the monitor screen. They can be configured to show beside the measurement numerics, beside the ECG wave, or beside the ST snippet.

A positive ST value indicates ST segment elevation; a negative value indicates depression.

ST numerics are displayed in the order in which you select ST leads for analysis. If there is additional space in the field assigned to ST numerics, the monitor will display extra numerics in the order in which they appear in the list in **Setup ST Leads**, in the **Setup ST Analysis** menu. Any ST leads switched on for analysis that do not fit in the assigned numerics field are shown in succession in place of the last ST numeric.

ST Index

The ST index numeric (**STindx**) is the sum of the absolute values for the ST leads V2, V5, aVF. Because it is based on absolute values, it is always a positive number. If you haven't selected one of the leads V2, V5, and aVF for ST analysis, the ST index numeric will display a question mark "?".

To switch the ST index numeric on or off for display, in the **Setup ST Analysis** menu, select **ST-Index** to toggle between **On** and **Off**.

ST Snippets

ST snippets show a one second wave segment for each measured ST lead. The most recent snippet is drawn in the same color as the ECG wave, usually green, superimposed over the stored baseline snippet, drawn in a different color. The comparison shows any deviation in the measurement since the baseline snippet was stored, for example as a result of a procedure carried out on the patient. The information is updated once per minute.

If you do not see ST snippets on the Screen, select the Screen name in the Monitor Info Line and select a Screen configured to show snippets from the pop-up list of available Screens.

ST View Window

The **ST View** Window shows a current ST snippet and numeric with a baseline snippet and numeric. The two snippets are in different colors, so that you can differentiate between them easily and see at a glance which numerics belong to which snippet. In the upper left corner the current lead and the ISO/J-Point mode for the current snippet and the baseline snippet is shown. On the right side all available ST numerics are shown. The date and time of the baseline snippet is shown at the bottom of the window.

The **ST View** Window opens with the ST pop-up keys **Current / Baseline / Overlap** (to select viewing mode), **Show Points / Hide Points**, **Update Baseline**, **Record ST**, **STE View**, **Adjust ST Points**, **ST Map**, **Setup ST** and arrow keys for scrolling through the available leads.

To view the **ST View** window, select any snippet on the Screen.

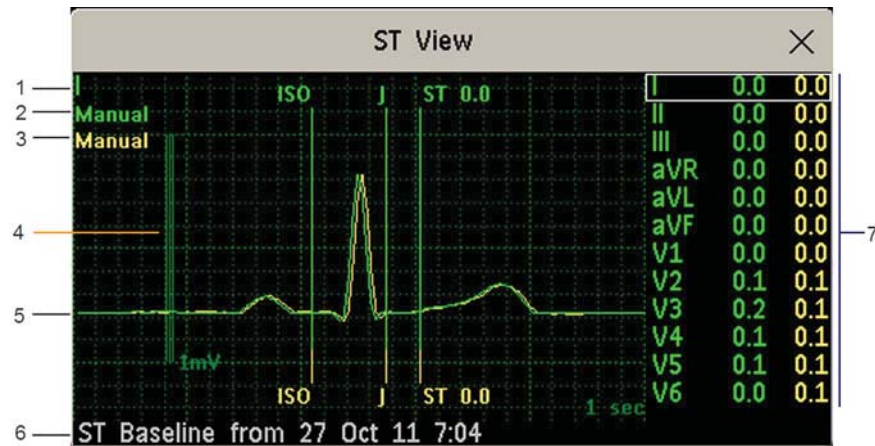

- 1 Current Lead
- 2 ISO/J-point mode for current snippet
- 3 ISO/J-point mode for baseline snippet
- 4 1 mV calibration bar
- 5 Current ST snippet and ST baseline snippet overlapped
- 6 Timestamp of most recently stored baseline snippet
- 7 All available ST numerics for current snippet and baseline snippet

The ST point, J-point and ISO point can be hidden using the **Hide Points** pop-up key.

STE View Window

The **STE View** window shows a current ST snippet and STE numeric with an ST baseline snippet. The two snippets are in different colors, so that you can differentiate between them easily. In the upper left corner the current lead is shown. On the right side all available STE numerics are shown. The date and time of the ST baseline snippet is shown at the bottom of the window.

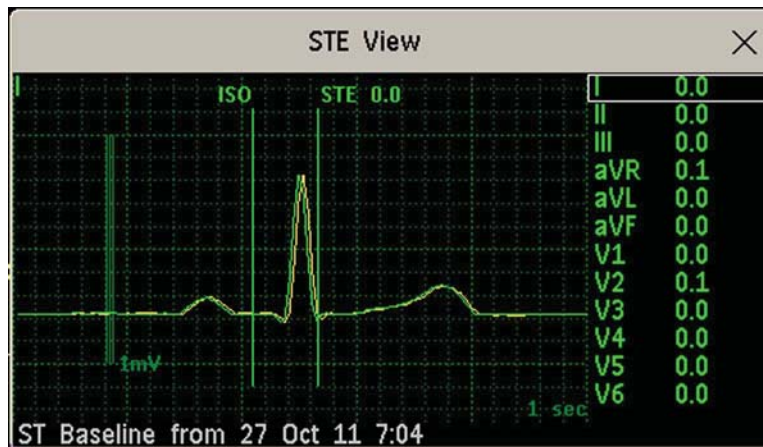

The **STE View** window opens with the pop-up keys **Current / Baseline / Overlap** (to select viewing mode), **Show Points/Hide Points**, **Record STE**, **ST View**, **ST Map**, **Setup ST** and arrow keys for scrolling through the available leads.

The ST point, J-point and ISO point can be hidden using the **Hide Points** pop-up key.

Updating ST Baseline Snippets

ST analysis requires valid samples to measure and store a snippet. ST Snippets and ST values are updated every minute. If there is artifact in the signal, it may take longer for an ST snippet and an ST value to appear.

The first baseline is stored automatically after ST monitoring is started, or when a new patient is admitted.

To update ST baselines,

- 1 Select an ST snippet to open the **ST View** window.
- 2 In the **ST View** window, select **Update Baseline** to store all current snippets as baselines. This deletes all previously-stored baselines.

An ST baseline copy is also stored in the Multi-Measurement Module, for transport purposes.

Recording ST Segments

To record all currently available ST snippets and baselines, in the **ST View** window, select the pop-up key **Record ST**.

About the ST Measurement Points

The ST value for each beat complex is the vertical difference between the ISO point and the ST point, as shown in the diagram below. The isoelectric (ISO) point provides the baseline, the ST point is at the midpoint of the ST segment. The J point is where the QRS complex changes its slope; as it is a fixed distance away from the ST point, it can be useful to help you position the ST point correctly.

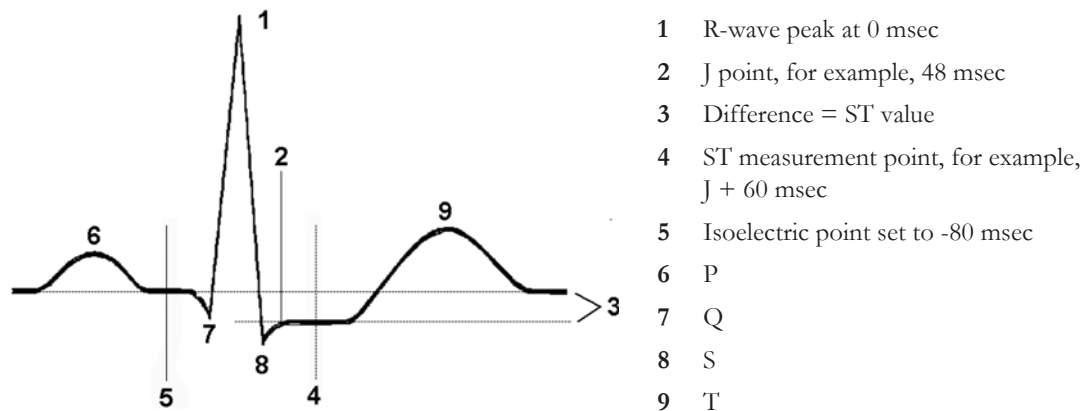

CAUTION

If using ST analysis, the ST measurement points need to be adjusted when you start monitoring, and if the patient's heart rate or ECG morphology changes significantly, as this may affect the size of the QT interval and thus the placement of the ST point. Artifactual ST segment depression or elevation may occur if the isoelectric point or the ST point is incorrectly set.

Always ensure that ST measurement points are appropriate for your patient.

Setting ISO and J-Point Detection Mode

There are two modes for ISO and J-point detection: **Auto** and **Manual**. In **Manual** mode you can set the measurement points yourself. In **Auto** mode the measurement points will be determined automatically.

To set the detection mode, in the **Setup ST Analysis** window,

- 1 Select **ISO/J Point**.
- 2 Select **Auto** or **Manual** mode.

Adjusting ST Measurement Points

If the ISO and J-point detection mode is set to **Manual**, all three measurement points can be set. In **Auto** mode, only the ST point can be changed.

To adjust the ST measurement points, in the **Setup ST Analysis** menu,

- 1 Select **Adjust ST Points** to open the **Adjust ST Points** window.
Alternatively, you can use the **Adjust ST points** pop-up key in the **ST View** window.
- 2 Select a suitable ECG lead for ST measurement, with a visible J-point and a visible P wave. Use the up and down arrow keys to scroll through the ST snippets for the other ECG leads.
- 3 Use the **Select Point** pop-up key to scroll through the points and activate the point you need to adjust, then use the left and right arrow keys to move the measurement point. Each point is highlighted while active.

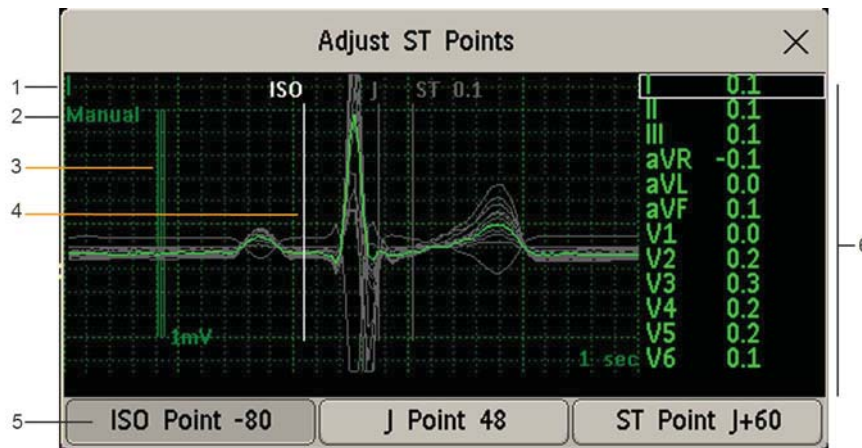

- 1 ST label
- 2 Current ISO/J-point detection mode
- 3 1 mV calibration bar
- 4 Cursor for adjusting ISO points
- 5 Highlighted ISO point
- 6 All available ST numerics for current snippet

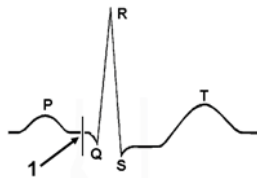

The ISO-point cursor (1) positions the isoelectric point relative to the R-wave peak. The relation is shown beside the ISO-point in milliseconds. Position the ISO-point in the middle of the flattest part of the baseline (between the P and Q waves or in front of the P wave).

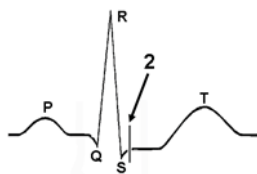

The J-point cursor (2) positions the J-point relative to the R-wave peak. It helps you to correctly position the ST-point. Position the J-point at the end of the QRS complex and the beginning of the ST segment.

The J-point cursor is not available if your monitor is configured to let you set the ST point directly.

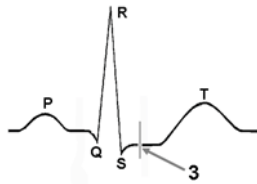

To position the ST-point (3) relative to the J-point:

select either **J+60** or **J+80**. Select **J Point** and use the arrow keys to move the J-Point and position the ST-point at the midpoint of the ST segment.

To position the ST-point directly:

select **ST Point** and use the left and right arrow keys to position the ST point at the midpoint of the ST segment.

- 4 Select the **Apply Changes** pop-up key to activate the new ST measurement points and recalculate all ST values.

The most recent ST Points adjustment time is displayed in the **Adjust ST Points** window. This information is cleared when a patient is discharged or when a new Profile is loaded into the monitor.

- 5 To update the ST snippet shown in the **Adjust ST Points** window, select the **Update** pop-up key.

ST Alarms

ST alarms are yellow alarms. Each ST lead has its own alarm limit. ST alarms are triggered when an ST value exceeds its alarm limit for more than one minute. Switching ST alarms off switches off alarms for all ST leads.

If more than one ST measurement is in alarm, the monitor only displays the alarm message of the ST lead which is currently furthest from its set alarm limits.

Changing ST Alarm Limits

The monitor can detect alarms on each ST lead separately, so you can set high and low ST alarm limits individually for each ST lead. When two contiguous leads are available, ST alarms will be generated when ST values of the two contiguous leads are outside the limit. When no contiguous lead is available an ST alarm is generated when the ST value of the single lead is outside the limit.

Set the high and low alarm limits based on your assessment of the patient's clinical condition, unit protocols, physician orders or medication-specified limits. A good guideline is + 1.0 mm or - 1.0 mm from the patients's ST, or follow your hospital protocol.

- 1 In the **Setup ST Analysis** menu, select the alarm to be adjusted.
- 2 Select the appropriate setting.

STE Alarms

The STE alarm is a yellow alarm. It can be switched on and off in the **Setup ST Elevation** menu but the limits can only be changed in Configuration mode. The STE alarm limits are gender specific and can be set individually for limb leads, V2/V3 leads, V1/V4/V5/V6 leads, V7/V8/V9 leads and V3R, V4R, V5R, V6R leads. The default values, for example on V2 and V3 1.5 mm for females and 2.0 mm for males, are based on the recommendations from the American Heart Association and American College of Cardiology.

The ST Elevation measurements with automated J-point determination generate ST Elevation alarms, in addition to the ST measurements at the user-defined ST point (J+offset), which may be useful for ST depression alarms. When ST and STE analysis are both in use, this may result in redundant alarms for ST

elevations. Because of the different measurement points, there may be different values obtained. Thus there could be an ST alarm and an STE alarm but the STE alarm may announce sooner based upon the values obtained.

Viewing ST Maps

The monitor can derive a multi-axis portrait (map) from the ST analysis to help you detect changes in ST values. Two planes obtained from a multi-lead ECG are displayed in a multi-axis diagram, where each axis represents a lead. The value at the ST point is given. The position of the axes within the diagram correspond to the placement of the ECG leads. Each ST value is assigned to either a limb lead, or to a chest lead. Every axis shows the polarity of the lead it represents. By joining adjacent ST values, the monitor obtains an ST map. The contour line and the map shading are shown in the same color as the ECG parameter.

Viewing an ST Map

To display an ST map,

- In the **Main Setup** menu, select **ST Map**.

Current View

In current view, the monitor displays an ST map that corresponds to the current ST values.

The left of the following diagrams shows leads I, II, III, aVR, aVL, and aVF on the limb leads plane. On the right, the V-leads V1, V2, V3, V4, V5, V6 (and V7, V8, V9, V3R, V4R, V5R, V6R, if configured) are on the chest leads plane.

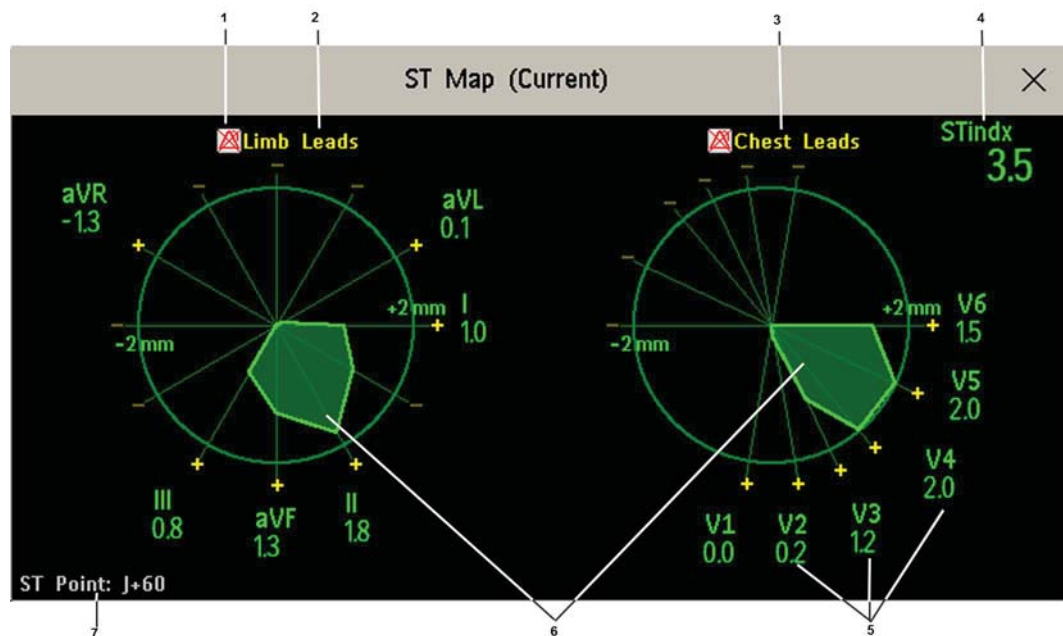

- 1 ST Alarm status indicator
- 2 Limb Leads
- 3 Chest Leads
- 4 ST index
- 5 Label, value and polarity of corresponding lead
- 6 ST map
- 7 The position of the current ST measurement point

If an ST lead is switched off, its axis is not shown in the map.



If a lead is in INOP (the value is being measured but is invalid or unavailable because, for example, the corresponding ECG electrode is off), the area formed by the remaining ST leads is left open.

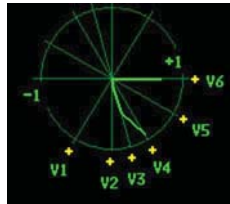

Trend View

In trend view, you can see up to four trended ST maps, and the current ST map, simultaneously. You can configure the time interval between trended samples. The most recent map is shown in the same color as the parameter itself. Past values change from white through dark gray. In the diagram below, the time interval between trends is one minute. The first trended sample is white and is one minute old. The second trended sample corresponds to the ST values two minutes ago and so forth. The ST values on the diagrams show the current ST values.

If a lead is turned off, its axis is no longer shown. This has no impact on the presentation of trended values that were recorded while the lead was still on.

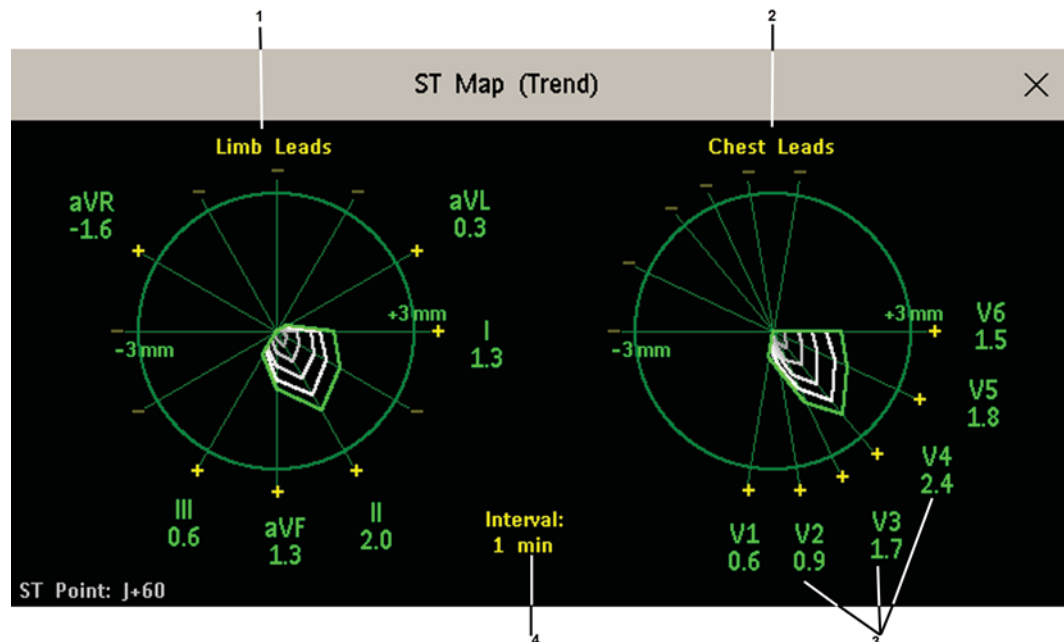

- 1 Limb leads map
- 2 Chest leads map
- 3 Current ST values
- 4 Trending interval

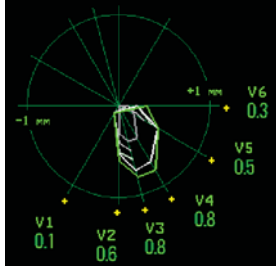

In this diagram, V4 was either temporarily switched off, or in INOP, for around 30 seconds. No data was recorded. Consequently, the affected maps are not closed.

Working in the ST Map Task Window

You may need to activate the ST map task window to see all the data, and to access the pop-up keys. Select the map view on screen to activate its task window. Once you activate it, you can perform the tasks detailed here.

Switching Between ST Map Views

To switch between views,

- Select **Current View** or **Trend View** to toggle between views.

If your trend view is empty, you need to adjust the priority of this measurement in the trending priority list. See “Trend Priority” on page 346.

Displaying an ST Reference Baseline

You can display an ST reference baseline for the current view, or for the trended view. The baseline is shown in yellow. However, if the ECG color is yellow, the baseline is shown in green. Use this baseline to detect ST changes. The baseline is derived automatically whenever the monitor relearns arrhythmia and also on user request.

Select **Show Baseline/Hide Baseline** to toggle between baseline display on and off.

Updating an ST Map Reference Baseline

To update the baseline,

- In the **Setup ST Analysis** menu, select **ST View** then select **Update Baseline**.

Changing the Scale of the ST Map

To change scale,

- Select **Size Up** or **Size Down** to alter the size at which monitor displays the map.

Changing the Trending Interval

To determine how frequently the monitor displays a trended sample,

- 1 In Trend view, select **Select Interval**.
- 2 Select the required interval from the menu. The interval ranges between 12 seconds to 30 minutes.

Printing an ST Map Report

To print the most recently viewed (current or trend) window,

- 1 Select **Main Setup** then select **Reports**.
- 2 Select **ST Map Report**.
- 3 Press **Print**.

Viewing STE Maps

The STE Map displays STE values, ST values measured at the J point, together with the STE Limits as configured in the **Setup ST Elevation** menu for the gender of the current patient. Just like ST Map, it displays two planes obtained from a multi-lead ECG in a multi-axis diagram, where each axis represents a lead. The position of the axes within the diagram correspond to the placement of the ECG leads. Each STE value is assigned to either a limb lead, or to a chest lead. Every axis shows the polarity of the lead it represents. The STE limits are indicated by a gray colored area which contains all values that lie above those limits. If the ECG parameter color is white, shades of green are used instead.

If two contiguous leads exceed the corresponding STE limits, the violation area between the two STE values and two corresponding limit values is colored in red. If the ECG parameter color is red, green is used instead.

If the gender of the patient is not specified, the STE Map does not show any limits and does not indicate any limit violations.

The STE Map does not provide Trend View or the ST baseline.

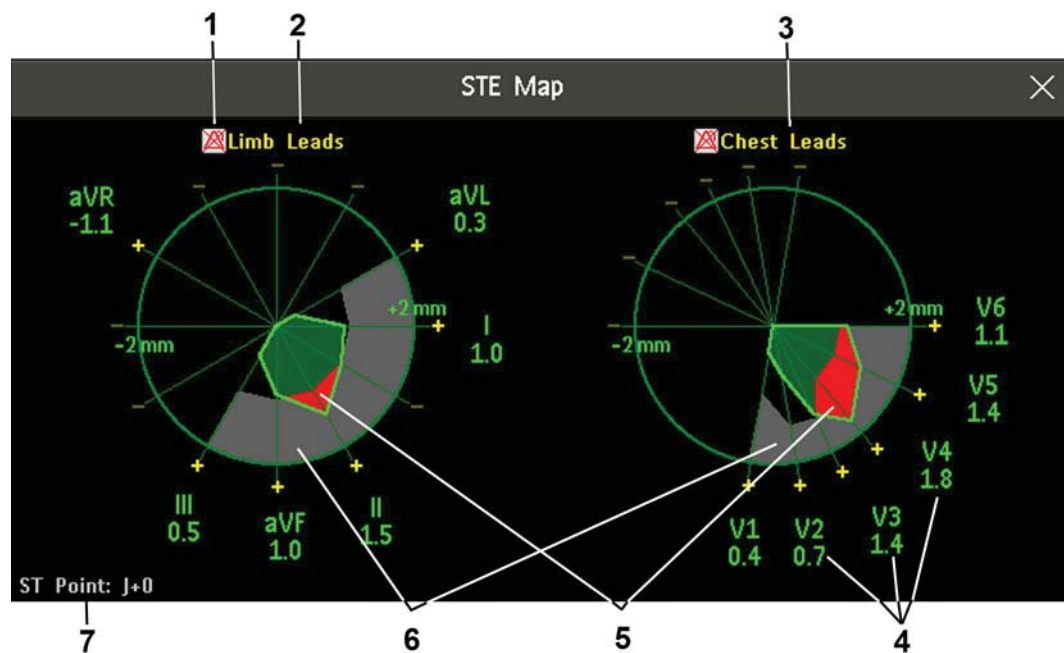

- 1 STE Alarm status indicator
- 2 **Limb Leads**
- 3 **Chest Leads**
- 4 Label, value and polarity of corresponding lead
- 5 STE Limit Violations
- 6 STE Limit Area
- 7 The position of the current ST measurement point (always J + 0)

Viewing an STE Map

To display an STE map,

- In the **Main Setup** menu, select **STE Map**.

Working in the STE Map Task Window

You may need to activate the STE map task window to see all the data, and to access the pop-up keys. Select the map view on screen to activate its task window. Once you activate it, you can perform the tasks detailed here.

Changing the Scale of the STE Map

To change scale,

- Select **Size Up** or **Size Down** to alter the size at which monitor displays the map.

Printing an STE Map Report

To print the most recently viewed window,

- 1 Select **Main Setup** then select **Reports**.
- 2 Select **STE Map Report**.
- 3 Press **Print**.

Switching between STE Map and ST Map

If you are running ST Map or STE Map as an embedded screen application, you can switch back and forth between STE Map and ST Map by selecting the **Change Map** pop-up key.

Note that changes made here will be saved in the current screen.

About QT/QTc Interval Monitoring

The QT interval is defined as the time between the beginning of the Q-wave and the end of the T-wave. It measures the total duration of the depolarization (QRS duration) and repolarization (ST-T) phases of the ventricular action potential. QT interval monitoring can assist in the detection of prolonged QT interval syndrome.

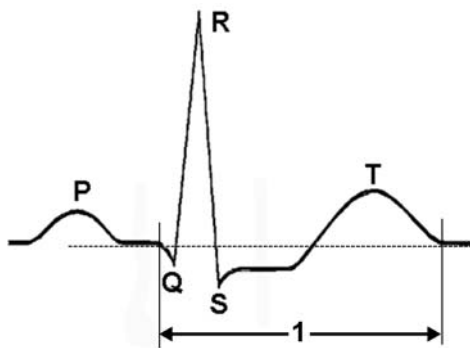

The QT interval (1) has an inverse relationship to heart rate. Faster heart rates shorten the QT interval and slower heart rates prolong the QT interval. Therefore there are several formulas used to correct the QT interval for heart rate. The heart rate corrected QT interval is abbreviated as QTc. The monitor uses as a default the Bazett correction formula and the alternative Fridericia formula can be selected in Configuration Mode.

For QT interval monitoring to be effective, basic or enhanced arrhythmia monitoring should be turned on.

QT Measurement Algorithm

The QT values are updated every five minutes except in the initial phase (first five minutes) where they are updated once per minute. Normal or atrial paced beats and beats with a similar morphology are averaged to form a representative waveform for further processing. Normal beats followed by a premature QRS will be excluded from the measurements to prevent the premature beat from obscuring the end of the T-wave. If the algorithm cannot form a representative waveform, for example because the morphology of the beats is

too varied, a **Cannot Analyze QT** INOP will be generated after 10 minutes. This is also the case if normal beats have been falsely labeled so that the algorithm does not have enough valid beats to make QT measurements. No QT value is calculated if the QT-HR is >150 bpm (Adult) or >180 bpm (Pedi/Neo).

Because of the different algorithm approaches, a QT/QTc measurement from a diagnostic 12-lead program may differ from the realtime measurement on the monitor.

Where Can I Find More Information?

See the Application Note on QT/QTc Interval Monitoring and the QT Interval Monitoring Quick Guide supplied on your documentation DVD for detailed information on the QT algorithm and performance.

Indications For Use Of QT Interval Monitoring

Of special concern for QT monitoring is the administration of QT prolonging drugs to patients identified with risk factors for Torsade de Pointe. Females, older patients and patients with bradycardia, impaired left ventricular function (ischemia, left ventricular hypertrophy), hypokalemia and hypomagnesemia are in this increased risk category.

Limitations For Use Of QT Interval Monitoring

Some conditions may make it difficult to achieve reliable QT monitoring, for example:

- the T-wave is very flat
- T-waves are not well defined due to atrial flutter or atrial fibrillation
- the end of the T-wave is difficult to define because of the presence of U-waves
- a high heart rate causes the P-wave to encroach on the end of the previous T-wave
- noise or high QRS morphology variation

For these cases you should select a lead with a good T-wave amplitude and no visible flutter activity, and without a predominant U-wave or P-wave.

Some conditions such as left or right bundle branch block or hypertrophy can lead to a widened QRS complex. If a long QTc is observed you should verify it to ensure that it is not caused by QRS widening.

Because normal beats followed by ventricular beats are not included in the analysis, no QT measurement will be generated in the presence of a bigeminy rhythm.

If the heart rate is extremely high (over 150 bpm for adults and over 180 bpm for pediatrics and neonates) QT will not be measured.

When the heart rate changes, it can take several minutes for the QT interval to stabilize. For reliable QTc calculation it is important to avoid a region where the heart rate is changing.

WARNING

QT/QTc measurements should always be verified by a qualified clinician.

Selecting the QT Leads

For QT Monitoring you can select one of the following three modes:

- All Leads mode - all available leads (I, II, III, V, MCL, V1 - V9, V3R to V6R) are used to produce a global QT measurement. For EASI lead placement, directly acquired AI, AS and ES leads are used.
- Primary-Lead mode - the primary lead will be used for QT measurement. If the original primary lead becomes unavailable or is changed, QT measurement will continue with the new primary lead.
- Single-Lead mode - a single lead selected from all available leads (except the augmented leads) will be used for QT measurement. QT measurement will stop if the selected lead becomes unavailable.

To select the mode,

- 1 Select the QT numeric to enter the **Setup QT Analysis** window.
- 2 Select QT Lead and select **All, Primary Lead** or one of the available single leads.

When using the All Leads mode, make sure when you compare QT values that they are based on the same set of leads.

Changing the lead(s) used for QT measurements will not cause the baseline to be reset.

QT View

In the **QT View** window you can verify that the QT algorithm detects correct Q and T points.



The current waves are shown in the upper half of the window and the baseline waves in a different color below. The Q and T points are marked with a vertical line. By selecting one of the lead labels at the top of the window you can highlight the corresponding wave; the other waves are shown in gray. The underlined lead labels are the leads used for the QT calculation. By selecting the numeric area you can highlight all underlined leads.

If EASI or Hexad lead placement is in use, the corresponding lead placement label will be shown.

Changing The View To A Single Wave Set

To view one set of waves in a larger scale, you can cycle through the different views,

- 1 Select **Current** view to see the set of current waves.
- 2 Select **Baseline** view to see the set of baseline waves.
- 3 Select **Split** view to return to the combined view with current and baseline waves.

Setting The QT Baseline

In order to quantify changes in the QTc value, you can set a QTc baseline. For example to assess the effect of medication on the QT interval you can set the current value as the baseline before you begin medication. This baseline will then be used to calculate the Δ QTc value.

To set the baseline,

- Select **Set Baseline** and set the value.

If no baseline has been set for this patient, the first five minute value after the start of monitoring is automatically set as baseline. If you set a new baseline the previous baseline is discarded. As the Δ QTc alarm is based on the difference between the baseline and the current value, setting an inappropriate new baseline may prevent a Δ QTc alarm from being generated. Discharging a patient clears the baseline.

Printing The QT Waves

To start a printout,

- Select **Print QT**.

Recording The QT Waves

To start a recording,

- Select **Record QT**.

QT Alarms

There are two QT alarms, QTc high limit alarm and Δ QTc high alarm. The QTc high limit alarm is generated when the QTc value exceeds the set limit for more than 5 minutes. The Δ QTc alarm is generated when the difference between the current value and the baseline value exceeds the set limit for more than 5 minutes.

The **Cannot Analyze QT INOP** and the **-?-** will be displayed when no QT measurement could be calculated for 10 minutes. Up to this time the previous valid value will be displayed. The following additional messages on the cause of the invalid measurements may also be displayed.

Additional Message	Cause of Invalid QT Measurement
QT Startup	QT monitoring was just turned on or has been reset
Asystole or Leads Off	1 Not all specified leads needed to perform QT analysis are available, or 2 Asystole condition is detected
Too few N labeled beats	Not enough valid QRS complexes to generate a QT measurement
Invalid Rhythm for QTc	Not enough valid R-R intervals to generate QT-HR, the averaged HR used for QTc calculation
High QT-HR	QT-HR exceeds the specified upper limit of 150 bpm (for adults) or 180 bpm (for neonates and pediatrics)
Small R Wave	R-wave of the signal is too small
Small T Wave	T-wave of the signal is too small
End of T not Detected	End of the T-Wave cannot be accurately detected
QT out of Range	QT measurement is outside the specified range of valid QT values (200-800 msec)
QTc out of Range	QTc measurement is outside the specified range of valid QTc values (200-800 msec)
QTc Erratic	QTc measurements are not stable

Switching Individual QTc Alarms On and Off

Each QTc alarm can be switched off individually.

To switch an alarm on or off, in the **Setup QT Analysis** menu, select **QTc High Alarm** or **Δ QTc High Alarm** to toggle between **On** and **Off**.

Changing QTc Alarm Limits

Set the high alarm limits based on your assessment of the patient's clinical condition, unit protocols, physician orders or medication specified limits.

- 1 In the **Setup QT Analysis** menu, select **QTc High Limit**.
- 2 Select the appropriate setting.
- 3 Select **Δ QTc High Limit**.
- 4 Select the appropriate setting.

Switching QT Monitoring On and Off

To switch all QT monitoring on or off, in the **Setup QT Analysis** menu, select **QT Analysis** to switch between **On** and **Off**.

Monitoring Pulse Rate

The pulse numeric counts the arterial pulsations that result from the mechanical activity of the heart in beats per minute (bpm). You can display a pulse from any measured SpO₂ signal (pleth wave), or any arterial pressure (P, ABP, ART, Ao, PAP, UAP, FAP, BAP: see the “[Monitoring Invasive Pressure](#)” chapter for an explanation of the pressure labels). The displayed pulse numeric is labeled and color-coded to match its source wave. If the pulse numeric is not displayed, see the **Setup Pulse** menu to check whether it is switched on.

Entering the Setup Pulse Menu

If a pulse numeric is displayed on the screen, select it to enter the setup menu for that pulse source. If no pulse numeric is visible, in the setup menu from the measurement, select pulse with the correct source, e.g. **Pulse (HR)**.

System Pulse Source

The currently selected system pulse source is shown in the setup menus of the pulse source measurements. The pulse rate chosen as system pulse:

- is monitored as system pulse and generates alarms when you select pulse as the active alarm source
- is sent via the network to the Information Center, if available
- is trended in the HighRes Trends and stored in the monitor's databases.

To define which pulse rate is used as system pulse,

- 1 In the **Setup Pulse** menu, select **System Pulse**.
- 2 Select one of the SpO₂, cmResp or arterial pressure labels from the pop-up list, or select **Auto**.
If you select **Auto**, the monitor automatically chooses a pulse rate to be used as system pulse. It looks through the list from top to bottom and activates the first pulse rate that is switched on and available.

If your selected pulse source measurement becomes unavailable or is switched off, the monitor will use the next measurement from the list as system pulse until the selected pulse source measurement becomes available again.

Switching Pulse On and Off

To switch a particular pulse numeric on or off, enter the **Setup Pulse** menu via the measurement setup menu or wave menu of the pulse source. For example, to switch an SpO₂ pulse numeric on or off,

- 1 Enter the **Setup Pulse** menu by selecting the Pulse numeric or by selecting **Pulse** in the **Setup SpO₂** menu.
- 2 In the **Setup Pulse** menu, select the correct pulse label, e.g. **Pulse (SpO₂)**, to toggle between **On** and **Off**.

Using Pulse Alarms

You can change pulse rate alarm limits in the **ECG/Pulse Alarms** menu which can be accessed from the **Setup Pulse** menu or the **Setup ECG** menu by selecting **Alarm Source**. Changing the alarm limits for a specific Pulse numeric changes the alarm limits for all pulse rate alarms and heart rate alarms.

Pulse alarms are only generated when the active alarm source is set to **Pulse**, a pulse source is set as system pulse and pulse alarms are switched on.

Selecting the Active Alarm Source: ECG or Pulse?

In most cases the HR and Pulse numerics are identical. In order to avoid simultaneous alarms on HR and Pulse, the monitor uses either ECG **or** Pulse as its active alarm source. To change the alarm source, select **Alarm Source** in the **ECG/Pulse Alarms** menu, then select

- **ECG/Arrhythm:** if you want the HR to be the alarm source for HR/Pulse.
- **Pulse:** If you select Pulse as the active alarm source, the monitor will prompt you to confirm your choice. Be aware that if you select Pulse as the alarm source, all arrhythmia and ECG HR alarms are switched off.
- **Auto:** If the alarm source is set to **Auto**, the monitor will use the heart rate from the ECG measurement as the alarm source whenever the ECG measurement is switched on and at least one ECG lead can be measured without an INOP condition.

The monitor will automatically switch to Pulse as the alarm source if:

- a valid ECG lead can no longer be measured
and
- a Pulse source is switched on and available,

The monitor then uses the pulse rate from the measurement currently active as system pulse. While Pulse is the alarm source, all arrhythmia and ECG HR alarms are switched off. If an ECG lead becomes available again, the monitor automatically uses HR as alarm source.

NOTE

If ECG is switched off, the monitor will always change to Pulse as alarm source, if a Pulse is available. One exception to this rule can arise when you have a telemetry device paired with your monitor. The monitor ECG is then deactivated but the monitor may be configured to allow only ECG as the active alarm source. In this case the monitor will not switch to Pulse as alarm source and Pulse will not be available as a selection in the **ECG/Pulse Alarms** menu.

WARNING

Selecting Pulse as the active alarm source for HR/Pulse switches off the arrhythmia alarms listed in the section “[ECG and Arrhythmia Alarm Overview](#)” on page 164, including **Asystole**, **Vfib** and **Vtach** alarms, and the heart rate alarms. This is indicated by the message **ECG/Arrh AlarmsOff** (unless this has been configured off for your monitor), and the crossed-out alarm symbol beside the ECG heart rate numeric. The message **ECG/Arrh AlarmsOff** can be configured off, or to switch to a yellow (medium severity) INOP after a fixed number of hours.

High and low pulse rate and extreme bradycardia and extreme tachycardia alarms from pulse are active.

Alarm Source Selection Disabled

If you cannot change the alarm source, selection of the alarm source may be disabled. If you try to change the source, the monitor displays the message **To activate enter Config and enable Alarm Source Selection**. This setting can only be changed in Configuration Mode.

Changing HR/Pulse Alarm Limits

As Pulse and HR share the same high and low alarm limits, if you change the alarm limit in the **Setup Pulse** menu, the high or low alarm limits for HR in the **Setup ECG** menu change automatically, and vice versa. The only exceptions are caused by a low limit clamp for each measurement: the lowest value for Pulse when derived from SpO₂ is 30 bpm; from HR 15 bpm, and from Pressure 25 bpm.

Extreme Alarm Limits for Heart Rate

The extreme rate alarms, ***** Extreme Tachy** and ***** Extreme Brady**, are generated by the active alarm source, either HR or Pulse. The limits are set automatically by adding a set value (the Δ value) to the high and low alarm limits. So, changing the high and low alarm limits automatically changes the extreme alarm limits (within an allowed range, see [“Extreme Alarm Limits for Heart Rate”](#) on page 166 for details).

You need to know which value has been configured for your monitor.

- To see the values added to the high and low limit alarms to create the extreme rate alarms for your monitor, in the **Setup ECG** menu, see the menu items **Δ ExtrTachy** and **Δ ExtrBrady**.

QRS Tone

The source for the QRS tone can be set to automatically follow the alarm source, or set specifically to HR or Pulse. To set up the source:

- 1 In the **Setup Pulse** menu, select **QRS Tone**. The **Setup QRS Tone** menu opens.
- 2 Select **QRS Source** and then select the required source from the pop-up list.

You can also set up QRS tone modulation in the **Setup QRS Tone** menu. You can change the QRS tone volume in the **Setup SpO₂** and **Setup ECG** menus.

WARNING

The audible QRS tone might be influenced by external interference and is not intended to be used as a substitute for ECG based arrhythmia analysis.

If arrhythmia detection is needed, do not rely on the audible QRS tone.

Monitoring Respiration Rate (Resp)

For the respiratory measurement (Resp), the monitor measures the thoracic impedance between two ECG electrodes on the patient's chest. Changes in the impedance due to thoracic movement produce the Resp waveform on the monitor screen. The monitor counts the waveform cycles to calculate the respiration rate (RR).

Lead Placement for Monitoring Resp

Correct patient skin preparation techniques for electrode placement are important for Resp measurement: you will find this information in the chapter on ECG.

The Resp measurement uses the standard ECG cable sets and lead placements. You can use any of the different types of ECG cable sets - 3-lead, 5-lead, 6-lead or 10-lead, using either standard or EASI placement - to measure Resp, as long as you use ICU ECG cables.

The Resp signal is always measured between two of the ECG electrodes. Note that at least a standard 3-lead placement is required to measure Resp. The Resp measurement cannot be performed with only two electrodes.

Selecting the Resp Lead for Measurement

To choose the leads for the Resp measurement:

In the **Setup Resp** menu, select **Resp Lead** and choose one of the following vectors:

- **I (RA-LA)** or
- **II (RA-LL).**

Note that if EASI is configured, Respiration will be measured between the I and A electrodes.

Optimizing Lead Placement for Resp

If you want to measure Resp and you are already measuring ECG, you may need to optimize placement of the two electrodes between which Resp will be measured for some patients. Repositioning ECG electrodes from standard positions, especially when you are using EASI ECG electrode placement, results in changes in the ECG waveform and may influence ST and arrhythmia interpretation.

Cardiac Overlay

Cardiac activity that affects the Resp waveform is called cardiac overlay. It happens when the Resp electrodes pick up impedance changes caused by the rhythmic blood flow. Correct electrode placement can help to reduce cardiac overlay: avoid the liver area and the ventricles of the heart in the line between the respiratory electrodes. This is particularly important for neonates.

Lateral Chest Expansion

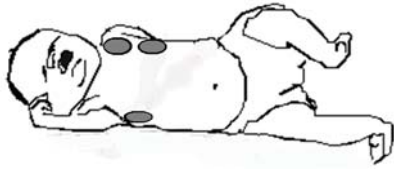

Some patients, especially neonates, expand their chests laterally. In these cases it is best to place the two respiratory electrodes in the right midaxillary and left lateral chest areas at the patient's maximum point of breathing movement to optimize the respiratory wave.

Abdominal Breathing

Some patients with restricted chest movement breathe mainly abdominally. In these cases, you may need to place the left leg electrode on the left abdomen at the point of maximum abdominal expansion to optimize the respiratory wave.

Understanding the Resp Display

The Resp measurement is displayed on the monitor as a continuous wave and a numeric respiration rate. If the detected respiration rate is close to the heart rate, this is indicated by the text **HR = RR** next to the respiration wave if you are in manual monitoring mode. Your monitor screen may look slightly different from the illustration.

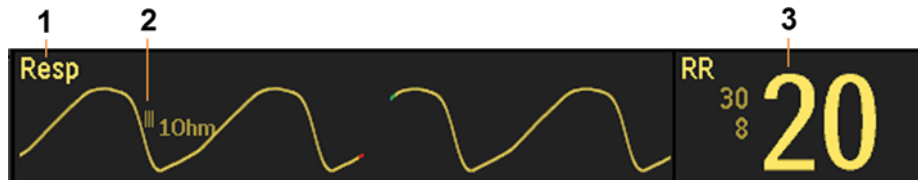

- 1 Resp wave label
- 2 One Ohm calibration bar
- 3 Resp numeric and label

Changing Resp Detection Modes

The Resp detection level can be set either automatically or manually.

- To change the resp detection mode, in the **Setup Resp** menu, select **Detection** to toggle between the settings.

Auto Detection Mode

In Auto Detection Mode, the monitor adjusts the detection level automatically, depending on the wave height and the presence of cardiac artifact. Note that in Auto Detection Mode,

- the detection level (a dotted line) is not displayed on the waveform,
- the algorithm expects a heart rate and therefore needs at least 3 electrodes attached to the patient.

Use Auto Detection Mode for situations where:

- the respiration rate is not close to the heart rate
- breathing is spontaneous, with or without continuous positive airway pressure (CPAP)
- patients are ventilated, except patients with Intermittent Mandatory Ventilation (IMV).

Manual Detection Mode

In Manual Detection Mode you must set the Resp detection level.

- In the **Setup Resp** menu, select **Manual Up** or **Manual Down**. Use the dotted detection level line in the Resp waveform to determine when the desired level is reached.

Once set, the detection level will not adapt automatically to different respiration depths. It is important to remember that if the depth of breathing changes, you may need to change the detection level.

Use Manual Detection Mode for situations where:

- the respiration rate and the heart rate are close.
- patients have Intermittent Mandatory Ventilation.
- respiration is weak. Try repositioning the electrodes to improve the signal.

Resp Detection Modes and Cardiac Overlay

In Auto Detection Mode:

If you are monitoring Resp and the ECG is switched off, the monitor cannot compare the ECG and Resp rates to detect cardiac overlay. The respiration detection level is automatically set higher to prevent the detection of cardiac overlay as respiration.

In Manual Detection Mode:

Cardiac overlay can in certain situations trigger the respiration counter. This may lead to a false indication of a high respiration rate or an undetected apnea condition. If you suspect that cardiac overlay is being registered as breathing activity, raise the detection level above the zone of cardiac overlay. If the Resp wave is so small that raising the detection level is not possible, you may need to optimize the electrode placement as described in the section “[Lateral Chest Expansion](#)” on page 200.

Changing the Size of the Respiration Wave

WARNING

When monitoring in Manual Detection Mode, make sure to check the respiration detection level after you have increased or decreased the size of the respiration wave.

- In the **Setup Resp** menu, select **Size Up** to increase the size of the wave or **Size Down** to decrease it.

Changing the Speed of the Respiration Wave

Resp waveforms are usually viewed at a slower speed than other waveforms. For this reason, the Resp measurement has its own speed control and is not affected by the wave speed settings of the other measurements.

- Select the Resp wave to enter the **Resp Wave** menu, then select **Change Speed**. Choose the required speed from the pop-up list. This defines the speed at which the wave is drawn across the screen in millimeters per second (mm/s).

Using Resp Alarms

Resp alarms can be switched on and off and the high and low alarm limits can be changed just like other measurement alarms, as described in the Alarms chapter.

Changing the Apnea Alarm Delay

The apnea alarm is a high priority red alarm used to detect apneas. The apnea alarm delay time defines the time period between the point where the monitor cannot detect any respiration activity and the indication of the apnea alarm.

- 1 In the **Setup Resp** menu, select **Apnea Time**.
- 2 Select the appropriate setting.

Resp Safety Information

WARNING

Respiration detection level

If you do not set the detection level for the respiration correctly in manual detection mode, it may not be possible for the monitor to detect apnea. If you set the detection level too low, the monitor is more likely to detect cardiac activity, and to falsely interpret cardiac activity as respiratory activity in the case of apnea.

Apnea

The respiration measurement does not recognize obstructive and mixed apneas - it only indicates an alarm when a pre-adjusted time has elapsed since the last detected breath.

The safety and effectiveness of the respiration measurement method in the detection of apnea, particularly the apnea of prematurity and apnea of infancy, has not been established.

Interference

If operating under conditions according to the EMC Standard EN 60601-1-2 (Radiated Immunity 3V/m), field strengths above 1V/m may cause erroneous measurements at various frequencies. Therefore it is recommended to avoid the use of electrically radiating equipment in close proximity to the respiration measurement unit.

Resp Accessories

To monitor respiration, use only the non-OR ECG accessories listed in the Resp section of the accessories chapter. You cannot measure respiration if you are using an orange OR ECG cable set. This is because of the higher internal impedance of the OR cable set, required for use if electrosurgery is being performed.

Rate adaptive pacemakers

Implanted pacemakers which can adapt to the Minute Ventilation rate may occasionally react on the Impedance measurement used by patient monitors for the determination of the Resp value and execute pacing with the maximum programmed rate. Switching off the Resp measurement can prevent this.

Monitoring SpO₂

Philips pulse oximetry uses a motion-tolerant signal processing algorithm, based on Fourier artifact suppression technology (FAST). It provides four measurements:

- Oxygen saturation of arterial blood (SpO₂) - percentage of oxygenated hemoglobin in relation to the sum of oxyhemoglobin and deoxyhemoglobin (functional arterial oxygen saturation).
- Pleth waveform - visual indication of patient's pulse.
- Pulse rate (derived from pleth wave) - detected pulsations per minute.
- Perfusion indicator - numerical value for the pulsatile portion of the measured signal caused by arterial pulsation.

The monitors are also compatible with the Nellcor™ OxiMax™ SpO₂ technology from Medtronic, Masimo SET® and Masimo rainbow SET™ technology. Where use of these technologies results in different behavior or has different requirements, the differences are described in these Instructions for Use.

WARNING

A pulse oximeter should be considered an early warning device. As a trend towards patient deoxygenation is indicated, blood samples should be analyzed by a laboratory CO-oximeter to completely understand the patient's condition.

Nellcor Patents

This device with Nellcor OxiMax technology is covered by one or more of the following US Patents and foreign equivalents:

5,485,847; 5,676,141; 5,743,263; 6,035,223; 6,226,539; 6,411,833; 6,463,310; 6,591,123; 6,708,049; 7,016,715; 7,039,538; 7,120,479; 7,120,480; 7,142,142; 7,162,288; 7,190,985; 7,194,293; 7,209,774; 7,212,847; 7,400,919.

No Implied License

Purchase of this device with Nellcor OxiMax technology conveys no express or implied license under any Covidien patent to use that device with any sensor not manufactured or licensed by Covidien.

Masimo Patents

This device, if equipped with Masimo SET technology is covered under one or more of the following U.S.A. patents: 5,758,644, 6,011,986, 6,699,194, 7,215,986, 7,254,433, 7,530,955 and other applicable patents listed at: www.masimo.com/patents.htm.

No Implied License

Possession or purchase of this device does not convey any express or implied license to use the device with unauthorized sensors or cables which would, alone, or in combination with this device, fall within the scope of one or more of the patents relating to this device.

SpO₂ Sensors

Depending on the purchased SpO₂ option, different sensors and adapter cables can be used. The sensors for the different options are color-coded to match the connectors. See the chapter for a compatibility table. Familiarize yourself with the instructions for use supplied with your sensor before using it. In particular, check that the sensor being used is appropriate for your patient category and application site.

CAUTION

Do not use OxiCliq disposable sensors in a high humidity environment, such as in neonatal incubators or in the presence of fluids, which may contaminate sensor and electrical connections causing unreliable or intermittent measurements. **Do not use** disposable sensors when there is a known allergic reaction to the adhesive.

Always use the MAX-FAST forehead sensor with the foam headband provided by Nellcor.

Applying the Sensor

- 1 Follow the SpO₂ sensor's instructions for use, adhering to all warnings and cautions.
- 2 Remove colored nail polish from the application site.
- 3 Apply the sensor to the patient. The application site should match the sensor size so that the sensor can neither fall off, nor apply excessive pressure.
When using the M1195A Infant Finger Sensor, select a finger or toe with a diameter of between 7 and 8 mm (0.27" and 0.31"). When applying a M1193A neonatal sensor do not overtighten the strap.
- 4 Check that the light emitter and the photodetector are directly opposite each other. All light from the emitter must pass through the patient's tissue.

WARNING

Proper Sensor Fit: If a sensor is too loose, it might compromise the optical alignment or fall off. If it is too tight, for example because the application site is too large or becomes too large due to edema, excessive pressure may be applied. This can result in venous congestion distal from the application site, leading to interstitial edema, hypoxemia and tissue malnutrition. Skin irritations or lacerations may occur as a result of the sensor being attached to one location for too long. To avoid skin irritations and lacerations, periodically inspect the sensor application site and change the application site regularly.

Venous Pulsation: Do not apply sensor too tightly as this results in venous pulsation which may severely obstruct circulation and lead to inaccurate measurements.

MRI Scanning: Do not use the pulse oximeter or oximetry sensors during magnetic resonance imaging (MRI) scanning. Induced current could potentially cause burns. The device may affect the MRI image, and the MRI unit may affect the accuracy of the oximetry measurements.

Damaged Sensors: Do not use damaged sensors / cables or sensors with exposed optical components.

Low Perfusion: With very low perfusion at the monitored site, the performance might be impaired and the SpO₂ readings may read lower than arterial oxygen saturation.

Conditions Affecting Performance: During hypotension, severe vasoconstriction, severe anemia, or hypothermia of the patient the performance may be impaired. Also in these conditions or when the patient is in cardiac arrest or in shock, it may not be possible to make measurements at all.

Ambient Temperature: At elevated ambient temperatures be careful with measurement sites that are not well perfused, because this can cause severe burns after prolonged application. All listed sensors operate without risk of exceeding 41°C on the skin if the initial skin temperature does not exceed 35°C.

Extremities to Avoid: Avoid placing the sensor on extremities with an arterial catheter, an NBP cuff or an intravascular venous infusion line.

Do not immerse the sensors.

Carefully route patient cabling to reduce the possibility of patient entanglement or strangulation.

Nellcor OxiMax technology: This product contains chemicals known to the state of California to cause cancer and birth defects or other reproductive harm.

Masimo SET technology: The Masimo SET technology only provides pulse rate values up to 240 bpm, therefore do not set the corresponding high pulse rate alarm limits to 240 bpm or above.

NOTE

NBP Alarm Suppression: The **NBP Alarm Suppr.** setting which can be made in Configuration Mode has no effect when using the SpO₂ measurement with Nellcor OxiMax or Masimo SET technology.

The use of NBP cuffs or other constricting devices on the same extremity as the SpO₂ sensor is not recommended.

Connecting SpO₂ Cables

Connect the sensor cable to the color-coded socket on the measurement device (Multi-Measurement Module or plug-in module). You can connect some Philips sensors directly to the measurement device. For other sensors, use the corresponding adapter cable.

CAUTION

Extension cables: Do not use more than one extension cable (M1941A). Do not use an extension cable with Philips reusable sensors or adapter cables with part numbers ending in -L (indicates "long" cable version).

Electrical Interference: Position the sensor cable and connector away from power cables, to avoid electrical interference.

Humidity: For neonatal patients, make sure that all sensor connectors and adapter cable connectors are outside the incubator. The humid atmosphere inside can cause inaccurate measurements.

Measuring SpO₂

- 1 Select the correct patient category setting (adult/pediatric and neonatal), as this is used to optimize the calculation of the SpO₂ and pulse numerics.
- 2 During measurement, ensure that the application site:
 - has a pulsatile flow, ideally with a perfusion indicator value above 1.0.
 - has not changed in its thickness (for example, due to edema), causing an improper fit of the sensor.

WARNING

- If not specified otherwise in the SpO₂ sensor's instructions for use, the following applies:
 - For fully conscious pediatric or adult patients, who have a normal function of perfusion and sensory perception at the measurement site:

To ensure skin quality and correct optical alignment of the sensor, inspect the application site when the measurement results are suspicious or when the patient complains about pressure at the

application site, but at least every 24 hours. Correct the sensor alignment if necessary. Move the sensor to another site, if the skin quality changes.

- For all other patients:

Inspect the application site every two to three hours to ensure skin quality and correct optical alignment. Correct the sensor alignment if necessary. If the skin quality changes, move the sensor to another site.

Change the application site at least every four hours.

- Injected dyes such as methylene blue, or intravascular dyshemoglobins such as methemoglobin and carboxyhemoglobin may lead to inaccurate measurements.
 - Inaccurate measurements may result when the application site for the sensor is deeply pigmented or deeply colored, for example, with nail polish, artificial nails, dye or pigmented cream.
 - Interference can be caused by:
 - High levels of ambient light (including IR warmers) or strobe lights or flashing lights (such as fire alarm lamps). (Hint: cover application site with opaque material.)
 - Another SpO₂ sensor in close proximity (e.g. when more than one SpO₂ measurement is performed on the same patient). Always cover both sensors with opaque material to reduce cross-interference.
 - Electromagnetic interference, especially at perfusion indicator values below 1.0 or signal quality indicator below medium.
 - Excessive patient movement and vibration.
-

SpO₂ Signal Quality Indicator (FAST SpO₂ only)

The SpO₂ numeric is displayed together with a signal quality indicator (if configured and enough space is available) which gives an indication of the reliability of the displayed values.

The level to which the triangle is filled shows the quality of the signal; the indicator below shows a medium signal quality, the signal quality is at a maximum when the triangle is completely filled.



Assessing a Suspicious SpO₂ Reading

Traditionally, pulse rate from SpO₂ was compared with heart rate from ECG to confirm the validity of the SpO₂ reading. With newer algorithms, such as FAST-SpO₂, this is no longer a valid criteria because the correct calculation of SpO₂ is not directly linked to the correct detection of each pulse.

When pulse rate is very low, or strong arrhythmia is present, the SpO₂ pulse rate may differ from the heart rate calculated from ECG but this does not indicate an inaccurate SpO₂ value.

If you doubt the measured SpO₂, use the signal quality indicator (if available) or the pleth wave and perfusion indicator instead to assess the signal quality.

WARNING

With pulse oximetry, sensor movement, ambient light (especially strobe lights or flashing lights) or electromagnetic interference can give unexpected intermittent readings when the sensor is not attached. Especially bandage-type sensor designs are sensitive to minimal sensor movement that might occur when the sensor is dangling.

Comparing Values and Waves

Be aware when using two different SpO₂ technologies that under certain conditions the displayed values and especially the perfusion values may differ due to the different algorithms used.

Masimo SET technology applies advanced filtering techniques which result in a slight delay of the displayed Pleth waveform relative to other waveforms.

Changing the Averaging Time

Depending on the monitor configuration, you may be able to change the averaging time for the SpO₂-related values.

The averaging time represents the approximate time period used for the calculation. The exact averaging algorithm and how it impacts the different SpO₂-related values depends on the SpO₂ technology (option) used and on the signal conditions. The longer the averaging time, the longer the time needed until the SpO₂-related values reflect the physiological event. Shorter averaging time is useful for situations where extremely fast responses of the measurements to changes are required or few artifacts are expected. Use longer averaging time where you expect the number of artifacts to be relatively high.

- 1 In the **Setup SpO₂** menu, select **Average**.
- 2 Select the required averaging time from the list.

Understanding SpO₂ Alarms

This refers to SpO₂ specific alarms. See the “[Alarms](#)” chapter for general alarm information. SpO₂ offers high and low limit alarms, and a high priority desat alarm. You cannot set the low alarm limit below the desat alarm limit.

CAUTION

If you measure SpO₂ on a limb that has an inflated noninvasive blood pressure cuff, a non-pulsatile SpO₂ INOP can occur. To avoid this, the monitor can be configured to suppress corresponding SpO₂ INOPs when it detects an inflated cuff (for FAST SpO₂ technology only).

If INOPs are suppressed, there may be a delay of up to 60 seconds in indicating a critical status, such as sudden pulse loss or hypoxia.

Alarm Delays

There is a delay between a change in the oxygen saturation at the measurement site and the corresponding alarm indication at the monitor. This delay has two components:

- **The general measurement delay time is the time between the occurrence of the saturation change and when the new value is represented by the displayed numerical values.** This delay depends on the algorithmic processing and the averaging time configured for SpO₂. The longer the averaging time configured, the longer the time needed until the numerical values reflect the change in saturation.
- **The time between the displayed numerical values crossing an alarm limit and the alarm indication on the monitor.** This delay is the sum of the alarm delay time configured for SpO₂, plus the system alarm delay. The system alarm delay is the processing time the system needs for any alarm to be indicated on the monitor, after the measurement has triggered the alarm. See “[Monitor Performance Specifications](#)” on page 481 for the system alarm delay specification.

For SpO₂ high and low limit alarms, there are two different types of alarm delay time. The **standard alarm delay** is set to a fixed value. The **Smart Alarm Delay** varies, based on an intelligent algorithm, and can be used instead of the standard alarm delay.

The **Desat** alarm always uses the standard alarm delay.

Standard Alarm Delay

The standard alarm delay time can be configured to a fixed value between 0 and 30 seconds, in 1 second steps.

Smart Alarm Delay

The Smart Alarm Delay feature tries to reduce "nuisance" alarms.

WARNING

Before using Smart Alarm Delays, make sure that you fully understand how the delay is applied and what the consequences are.

How Does it Work?

The monitor assesses the severity of a limit violation by looking at its magnitude and duration, and can delay the alarm, depending on the assessed severity. Examples for the delay are given in the table in the example below.

Clinical Example

You are monitoring a patient with a low SpO₂ limit of 90%. Then, while sleeping, your patient drops to 89% for 20 seconds, and then recovers.

The Smart Alarm Delay would tolerate this limit violation up to 50 seconds (upper shaded cell in the table) before issuing an SpO₂ low alarm. So in this case there would be no alarm notification.

If the SpO₂ drops further (e.g. to 85%), the tolerance time is much lower (10 seconds, see lower shaded cell).

Actual deviation from violated alarm limit	Resulting alarm notification delay according to selected mode		
	Short	Medium	Long
1%	25 sec (maximum delay)	50 sec (maximum delay)	100 sec (maximum delay)
2%	12 sec	25 sec	50 sec
3%	10 sec (minimum delay)	16 sec	33 sec
4%	10 sec	12 sec	25 sec
5%	10 sec	10 sec (minimum delay)	20 sec
6%	10 sec	10 sec	16 sec
7%	10 sec	10 sec	14 sec
8%	10 sec	10 sec	12 sec
9%	10 sec	10 sec	11 sec
>9%	10 sec	10 sec	10 sec (minimum delay)

Table with Detailed Delays for Specific Limit Violations

In the clinical example above, the **Medium** delay mode has been selected. For less stable or more robust patients, the tolerance time can be adjusted using **Short** or **Long** mode.

Smart Alarm Delay Dynamics

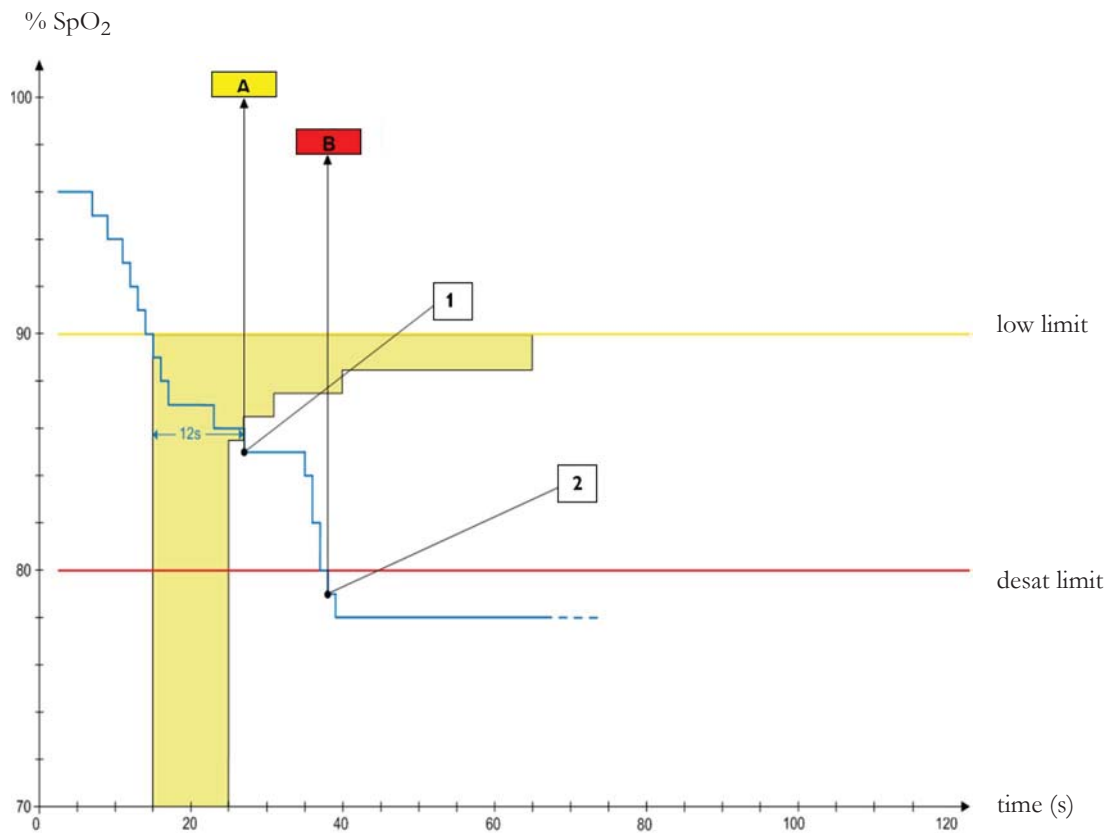

- 1 First trigger point - with the smart alarm delay setting "medium", the low alarm is triggered 12 seconds after the SpO₂ value has fallen below the low limit.
A - ** SpO₂ Low alarm
- 2 Second trigger point - with zero desat delay, the alarm is triggered as soon as the SpO₂ value falls below the desat limit.
B - * Desat** alarm

As long as the SpO₂ value stays in the shaded zone, the low alarm is delayed.

Setting Smart Alarm Delay Mode

To set the mode for Smart Alarm Delays, in the **Setup SpO₂** menu:

- 1 Check that **SmartAlarmDelay** is set to **On**.
This setting is made in Configuration Mode and will be shown in the menu in gray. If it is set to **Off**, a standard alarm delay is in use.
- 2 Select **High Alarm Delay** and choose **Short**, **Medium**, or **Long** mode.
- 3 Select **Low Alarm Delay** and choose **Short**, **Medium**, or **Long** mode.

If you also use monitors with earlier software revisions, be aware that smart alarm delays will not be used after a transfer to one of these monitors. Monitors with earlier software revisions will always use the standard alarm delay. If you are not sure whether a monitor has the Smart Alarm Delay function, check whether there is a **SmartAlarmDelay** entry in the **Setup SpO₂** menu.

Smart Alarm Delay Indicator

If the Smart Alarm Delay is switched on, a special indicator will be displayed next to the SpO₂ alarm limits. This indicator consists of a general alarm symbol with three blocks above and below it.



Indicator



Indicator with Numerics

The blocks above and below the alarm symbol indicate which Smart Alarm Delay modes have been set:



Short



Medium



Long

The blocks **above** the alarm symbol show the delay mode for the high limit, and the blocks **below** for the low limit.

When the SpO₂ value crosses an alarm limit, the delay period starts. During the delay period, the symbol is highlighted to indicate that an alarm limit has been violated:



If the SpO₂ value returns inside the limits during the delay period, the highlighting will be removed and no alarm is indicated. If the SpO₂ value is still outside the alarm limit at the end of the delay period, the alarm is indicated and the highlighting will be removed from the symbol.

Adjusting the Alarm Limits

In the **Setup SpO₂** menu:

- Select **High Limit** then choose the high alarm limit.
- Select **Low Limit** then choose the low alarm limit.

WARNING

High oxygen levels may predispose a premature infant to retrolental fibroplasia. If this is a consideration do NOT set the high alarm limit to 100%, which is equivalent to switching the high alarm off.

Adjusting the Desat Limit Alarm

The Desat alarm is a high priority (red) alarm notifying you of potentially life threatening drops in oxygen saturation.

- 1 In the **Setup SpO₂** menu, select **Desat Limit**.
- 2 Adjust the limit.

Pleth Wave

The Pleth wave is autoscaled to maximum display size. It decreases only when the signal quality becomes marginal. It is NOT directly proportional to the pulse volume. If you need an indication of change in pulse volume, use the perfusion indicator.

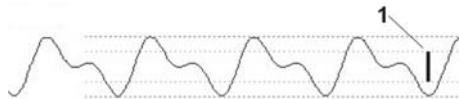

- 1 Minimum size for reliable SpO₂ value

Perfusion Numeric

The perfusion numeric (**Perf**) gives a value for the pulsatile portion of the measured signal caused by the pulsating arterial blood flow.

As pulse oximetry is based on the pulsatile nature of the signal, you can also use the perfusion numeric as a quality indicator for the SpO₂ measurement. Above 1 is optimal, between 0.3-1 is acceptable. Below 0.3 is marginal; reposition the sensor or find a better site.

Perfusion Change Indicator (Philips FAST SpO₂ and Nellcor OxiMax only)

The perfusion change indicator is a graphic symbol which shows the change in the perfusion value, relative to a reference value which you can set.

To set the current perfusion value as the reference value:

- In the **Setup SpO₂** menu, select **Set Perf Ref.**

When a reference value has been set, the perfusion change indicator is displayed next to the perfusion numeric.



Setting SpO₂/Pleth as Pulse Source

- 1 In the **Setup SpO₂** menu, select **Pulse (SpO₂)** to enter the **Setup Pulse** menu.
- 2 In the **Setup Pulse** menu, select **System Pulse** and select the correct SpO₂ label from the pop-up list.

Setting Up Tone Modulation

If tone modulation is on, the QRS tone pitch lowers when the SpO₂ level drops. Remember, the QRS tone is derived from either heart rate or pulse depending on which is currently set up as the QRS tone source (see “QRS Tone” on page 197).

- 1 In the **Setup SpO₂** menu, select **QRS Tone**. The **Setup QRS Tone** menu opens.
- 2 Select **Tone Modulation** to switch between **Yes** (for on) and **No** (for off).

Setting the QRS Volume

In the **Setup SpO₂** menu, select **QRS Volume** and set the appropriate QRS tone volume.

Calculating SpO₂ Difference

When a second SpO₂ measurement is present (through the MMX or X3 Multi-Measurement Module with dual SpO₂, the SpO₂ module, or through an external device), the monitor displays both SpO₂ values, and calculates the difference between them. The second value is subtracted from the first.

- 1 From the **Main Setup** menu, select **Measurements**.
- 2 From the **Setup ΔSpO₂** menu, select **First SpO₂**.
- 3 Choose the first measurement source.
- 4 Select **Second SpO₂**.
- 5 Choose the second measurement source.

Monitoring with Masimo rainbow SET

Masimo rainbow SET technology provides the following optional measurements, in addition to the standard SpO₂ measurement:

- SpCO
- SpMet
- SpHb/SpOC
- PVI
- Acoustic Respiration Rate (RRac)

Specific information for these measurements is included in this chapter.

Refer to the “Monitoring SpO₂” chapter for all general information on the SpO₂ measurement and all operating instructions. The information here is limited to the parts which differ from the standard SpO₂ information in that chapter.

Refer to the sensor's Direction for Use (DFU) for all information, warnings, and cautions, and all specifications that apply when using a Masimo sensor.

Masimo Patents

The Masimo technology in this product is covered under one or more patents as set forth at www.masimo.com/patents.htm.

No Implied License

Possession of the Masimo technology in this product does not convey any express or implied license to use the product with unauthorized sensors or cables that would, alone, or in combination with this product, fall within the scope of one or more of the patents relating to that product with Masimo technology.

Safety Information

General

WARNING

- A pulse oximeter is considered an early warning device. If a patient is monitored, and the SpHb values are high or low, or if the patient is diagnosed with hypoxemia, the blood samples should be analyzed by a laboratory CO-oximeter to completely understand the patient's condition.
 - EMI radiation interference from computer displays and/or LCD/plasma TVs can cause errors or incorrect Masimo rainbow SET measurements.
 - The Masimo rainbow SET technology only provides pulse rate values up to 240 bpm. To get pulse rate alarms, set the high alarm limit below 240 bpm.
-

WARNING

As with all medical equipment, carefully route patient cabling to reduce the possibility of patient entanglement or strangulation.

WARNING

Explosion hazard: Do not use the device in the presence of flammable anesthetics, or other flammable substance in combination with air, oxygen-enriched environments, or nitrous oxide.

WARNING

Interfering substances: Dyes, or any substance containing dyes, that change usual blood pigmentation may cause erroneous readings.

WARNING

Do not use the Masimo rainbow SET measurement during magnetic resonance imaging (MRI), or in an MRI environment.

WARNING

Do not use the Masimo rainbow SET measurement if the device appears or is suspected to be damaged.

WARNING

The Masimo rainbow SET measurement is not an apnea monitor.

WARNING

The Masimo rainbow SET measurement may be used during defibrillation, but this may affect the accuracy or availability of the parameters and measurements.

WARNING

The Masimo rainbow SET measurement should not be used for arrhythmia analysis.

WARNING

To protect from electric shock, always remove the sensor and completely disconnect the Masimo rainbow SET measurement accessories before bathing the patient.

WARNING

The Masimo rainbow SET measurement is intended only as an adjunct device in patient assessment. It should not be used as the sole basis for diagnosis or therapy decisions. It must be used in conjunction with clinical signs and symptoms.

WARNING

The Masimo rainbow SET technology only provides respiration rate values from 4 rpm to 70 rpm. For respiration rate limit alarms, set the high alarm limit below 70 rpm and the low alarm limit above 4 rpm.

CAUTION

- SpO₂, SpCO, SpMet, and SpHb are empirically calibrated monitoring healthy adult volunteers with normal levels of carboxyhemoglobin (COHb) and methemoglobin (MetHb).
 - Masimo rainbow SET technology cannot measure elevated levels of COHb or MetHb.
-

CAUTION

Loss of pulse signal can occur when:

- The sensor is too tight.
 - The patient has hypotension, severe vasoconstriction, severe anemia, or hypothermia.
 - There is arterial occlusion proximal to the sensor.
 - The patient is in cardiac arrest or is in shock.
-

CAUTION

Interference, resulting in inaccurate or no measurements, can be caused by:

- Significant levels of dysfunctional hemoglobins (e.g., carboxyhemoglobin or methemoglobin).
 - Hypotension, severe vasoconstriction, severe anemia, or hypothermia of the patient.
 - Elevated levels of Carboxyhemoglobin (COHb) leading to inaccurate SpO₂ measurements.
 - Elevated levels of Methemoglobin (MetHb) leading to inaccurate SpO₂ and SpCO measurements.
 - Dyes, or any substance containing dyes that change usual blood pigmentation.
 - Elevated levels of total bilirubin.
-

CAUTION

If using pulse oximetry during full body irradiation, keep the sensor out of the radiation field. If the sensor is exposed to the radiation, the reading might be inaccurate or the device might read zero for the duration of the active irradiation period.

CAUTION

Do not place the device on electrical equipment that may affect the device, preventing it from working properly.

CAUTION

If the Low Perf INOPs are frequently displayed, find a better perfused monitoring site. In the interim, assess the patient and, if indicated, verify oxygenation status through other means.

CAUTION

The patient monitor must be configured to match your local power line frequency to allow for the cancelation of noise introduced by fluorescent lights and other sources.

CAUTION

To ensure that alarm limits are appropriate for the patient being monitored, check the limits each time the device is used.

CAUTION

To minimize radio interference, other electrical equipment that emits radio frequency transmissions should not be in close proximity to the device.

CAUTION

When patients are undergoing photodynamic therapy, they may be sensitive to light sources. Pulse oximetry may be used only under careful clinical supervision for short time periods to minimize interference with photodynamic therapy.

CAUTION

Once the lifetime of a used sensor, adhesive, or patient cable has expired, monitoring of the corresponding parameters are no longer possible with this sensor, adhesive, or patient cable. Once the end of lifetime is reached, the sensor, adhesive, or patient cable continues to operate until power is removed from the measurement device (e.g. Multi-Measurement Module is moved to a different monitor), the sensor or patient cable is disconnected, or a sustained sensor off condition occurs.

CAUTION

When using two different SpO₂ technologies be aware that under certain conditions the displayed values and especially the perfusion values may differ due to the different algorithms used.

CAUTION

The 3D Perf Delta alarm is also cleared/disabled, when the sensor or the patient cable is disconnected or in the event of a sensor off condition.

CAUTION

The 3D Desat Index alarm restarts counting when power is removed from the measurement device (e.g. Multi-Measurement Module is moved to different monitor), the sensor or patient cable is disconnected, or in the event of a sensor off condition.

CAUTION

Masimo rainbow SET technology applies advanced filtering techniques which result in a slight delay of the displayed pleth waveform relative to other waveforms.

SpHb**CAUTION**

Variation in hemoglobin measurements may be profound and may be affected by sample type, body positioning, as well as other physiological conditions. As with most hemoglobin tests, Masimo rainbow SET technology test results should be scrutinized in light of a specific patient's condition. If any results show an inconsistency with the patient's clinical status, the measurement should be repeated with another measurement method and/or supplemented with additional test data.

Possible Causes of Inaccurate Readings**SpO₂**

- Improper sensor application.
- Elevated levels of COHb or MetHb: High levels of COHb or MetHb may occur with a seemingly normal SpO₂. When elevated levels of COHb or MetHb are suspected, laboratory analysis (CO-Oximetry) of a blood sample should be performed.
- Intravascular dyes, such as indocyanine green or methylene blue.
- Externally applied coloring and texture, such as nail polish, acrylic nails, glitter, etc.
- Elevated levels of bilirubin
- Severe anemia
- Low arterial perfusion
- Motion artifact

SpCO and SpMet

- Improper sensor application
- Intravascular dyes such as indocyanine green or methylene blue
- Abnormal hemoglobin levels
- Low arterial perfusion
- Low arterial oxygen saturation levels including altitude induced hypoxemia
- Elevated total bilirubin levels
- Motion artifact

SpHb and SpOC

- Improper sensor application
- Elevated PaO₂ levels
- Elevated levels of bilirubin
- EMI radiation interference
- Elevated carboxyhemoglobin levels
- Elevated methemoglobin levels
- Intravascular dyes such as indocyanine green or methylene blue
- Externally applied coloring and texture such as nail polish, acrylic nails, glitter, etc.
- Low arterial perfusion
- Low arterial oxygen saturation levels
- Motion artifact
- Hemoglobinopathies and synthesis disorders such as thalassemias, Hb S, Hb C, sickle cell, etc.
- Vasospastic disease such as Raynaud's
- Elevated altitude
- Peripheral vascular disease
- Liver disease

RRac

- Improper sensor application
- Low arterial perfusion
- Motion artifact
- Low arterial oxygen saturation
- Excessive ambient or environmental noise

Alarm Capabilities

The standard physiological limit alarm capabilities for SpO₂ and pulse rate also apply to the Masimo rainbow SET measurement. For details, refer to the monitor's Instructions for Use.

Additional Patient Alarm Messages

Alarm Message	From	Condition	Indication
** 3D Desat Index	Oxygen Saturation	The number of detected desaturations has exceeded the specified 3D Desat Index Count	SpO ₂ numeric flashes, yellow alarm lamp, alarm tone
** 3D Perf Delta	Perfusion Index	The perfusion index change from the Perf baseline has exceeded the selected Delta % Decrease value.	SpO ₂ numeric flashes, yellow alarm lamp, alarm tone
** <Perf Label> High	Perfusion Index	The perfusion index has exceeded the high alarm limit.	numeric flashes and high limit is highlighted, yellow alarm lamp, alarm tone
** <Perf Label> Low	Perfusion Index	The perfusion index has dropped below the low alarm limit.	numeric flashes and low limit is highlighted, yellow alarm lamp, alarm tone
** PVI High	Pleth Variability Index	The pleth variability index has exceeded the high alarm limit.	numeric flashes and high limit is highlighted, yellow alarm lamp, alarm tone
** PVI Low	Pleth Variability Index	The pleth variability index has dropped below the low alarm limit.	numeric flashes and low limit is highlighted, yellow alarm lamp, alarm tone
** RRac High	Acoustic Respiration Rate	The acoustic respiration rate has exceeded the high alarm limit.	numeric flashes and high limit is highlighted, yellow alarm lamp, alarm tone
** RRac Low	Acoustic Respiration Rate	The acoustic respiration rate has dropped below the low alarm limit.	numeric flashes and low limit is highlighted, yellow alarm lamp, alarm tone
*** RRac Pause	Acoustic Respiration Rate	No breath detected for a configured time period.	numeric flashes, red alarm lamp, alarm tone
** SpCO High	Carboxyhemoglobin Saturation	The carboxyhemoglobin saturation has exceeded the high alarm limit.	numeric flashes and high limit is highlighted, yellow alarm lamp, alarm tone
** SpCO Low	Carboxyhemoglobin Saturation	The carboxyhemoglobin saturation has dropped below the low alarm limit.	numeric flashes and low limit is highlighted, yellow alarm lamp, alarm tone
** <SpHb Label> High	Total Hemoglobin Concentration	The total hemoglobin concentration has exceeded the high alarm limit.	numeric flashes and high limit is highlighted, yellow alarm lamp, alarm tone
** <SpHb Label> Low	Total Hemoglobin Concentration	The total hemoglobin concentration has dropped below the low alarm limit.	numeric flashes and low limit is highlighted, yellow alarm lamp, alarm tone
** SpMet High	Methemoglobin Saturation	The methemoglobin saturation has exceeded the high alarm limit.	numeric flashes and high limit is highlighted, yellow alarm lamp, alarm tone
** SpMet Low	Methemoglobin Saturation	The methemoglobin saturation has dropped below the low alarm limit.	numeric flashes and low limit is highlighted, yellow alarm lamp, alarm tone

Alarm Message	From	Condition	Indication
** SpOC High	Total Oxygen Content	The total oxygen content has exceeded the high alarm limit.	numeric flashes and high limit is highlighted, yellow alarm lamp, alarm tone
** SpOC Low	Total Oxygen Content	The total oxygen content has dropped below the low alarm limit.	numeric flashes and low limit is highlighted, yellow alarm lamp, alarm tone

3D Alarms

The Masimo rainbow SET measurement provides additional alarms that are named 3D Alarms. 3D Alarms include:

- Desat Index 3D Alarm™ referred to within IntelliVue as 3D Desat Index
- 3D PI Delta Alarm™ referred to within IntelliVue as 3D Perf Delta

3D Desat Index

The 3D Desat Index alarm alerts you to an increasing number of smaller desaturations that may not exceed the low SpO₂ alarm threshold. The smaller desaturations provide an early indication that the patient's respiratory status is declining.

The SpO₂ alarm has to be on to set the 3D Desat Index. The 3D Desat Index alarm is issued when:

- a specified threshold (**Delta Threshold**) is exceeded
- for a specified number of desaturations (**Count**)
- over a specified period (**Period**).

The baseline to determine the desaturations is calculated automatically. The extended alarm text contains the maximum exceeded count.

3D Perf Delta

Changes in the peripheral perfusion are a valuable indicator of a patient's condition worsening, but they are difficult to identify and often missed. The 3D Perf Delta alarm helps you to notice early changes in peripheral perfusion.

A 3D Perf Delta alarm indicates that a patient's perfusion is deteriorating. The Perf alarms have to be on, to set the 3D Perf Delta. Set a Perf baseline as a reference for the current Perf value. Set the **Delta % Decrease** to a configurable value. The **Delta % Decrease** determines the delta from the set Perf baseline to the point where a 3D Perf Delta alarm is issued. Set the **Duration** to configure the time span in which you want to monitor the **Delta % Decrease** from the set Perf baseline. The 3D Perf Delta alarm is only enabled during the configured **Duration**.

The extended alarm text contains the maximum exceeded Perf Delta value.

SpO₂ Measurement with Masimo rainbow SET

Basic Measurements

Masimo rainbow SET technology has the same basic measurement functionality as Masimo SET SpO₂ measurements: SpO₂ (functional oxygen saturation), Pulse from Pleth, Perfusion Index, and an auto-scaled plethysmogram wave. The basic SpO₂ measurement functionality is described in the chapter “Monitoring SpO₂” on page 203.

NOTE

The **NBP Alarm Suppr.** setting has no effect when using the SpO₂ measurement with Masimo rainbow SET technology.

Optional Measurements

Masimo rainbow SET technology provides optional noninvasive measurements, if the corresponding option is activated in your device:

- **SpHb** measures the levels of total hemoglobin (SpHb) concentration in arterial blood.
- **SpOC** calculates the levels of total oxygen content in the arterial blood.
- **SpCO** measures the levels of carboxyhemoglobin saturation (reflecting the blood levels of carbon monoxide bound to hemoglobin) in arterial blood.
- **SpMet** measures the levels of methemoglobin saturation (SpMet) in arterial blood.
- **PVI** (pleth variability index) may show changes that reflect physiological factors such as vascular tone, circulating blood volume, and intrathoracic pressure excursions.
- **RRac** (respiration rate) provides a respiration rate value and an auto-scaled acoustic (acResp) waveform.

SpO₂ Average

If you switch from a Masimo rainbow SET measurement to a non-rainbow SET SpO₂ measurement, the **Average** setting is mapped as listed in the table:

Masimo rainbow SET Average	SpO ₂ Average
2 sec, 4 sec	5 sec
8 sec, 10 sec, 12 sec, 14 sec	10 sec
16 sec	20 sec

If you switch from a non-rainbow SET SpO₂ measurement to a Masimo rainbow SET measurement, the **Average** setting is mapped as listed in the table:

SpO ₂ Average	Masimo rainbow SET Average
5 sec	4 sec
10 sec	10 sec
20 sec	16 sec

Making Measurements**Selecting the Sensor**

Use only the accessories that are specified for use with this device, otherwise patient injury can result.

Not all sensors support all optional measurements. Some Masimo sensors require that certain options are activated in the measurement device. Otherwise those sensors are not compatible, and no measurements including SpO₂ measurements are possible. In this case, an INOP **Unkn.Sensor** is issued. For details and accuracy specifications for the specific sensor, refer to the sensor's DFU.

Applying the Sensor

Regarding the application of the sensor, follow the instructions given in the sensor's DFU while adhering to all warnings and cautions. Consider using the Masimo light shield to cover the sensor. Ensure to regularly inspect and reapply the sensor as indicated in the sensor's DFU.

NOTE

High-intensity extreme lights (such as pulsating strobe lights) directed on the sensor, may not allow the Masimo rainbow SET measurement to obtain vital sign readings. Use the Masimo light shield to cover the sensor.

Connecting Cables

For the Masimo rainbow SET measurements you require:

- Masimo rainbow SET compatible sensors
- adapter cables
- rainbow SET compatible sensor sockets at the monitor, the Multi-Measurement Module or the Masimo rainbow SET IntelliVue Module.

Connection Example showing the X3 Multi-Measurement Module

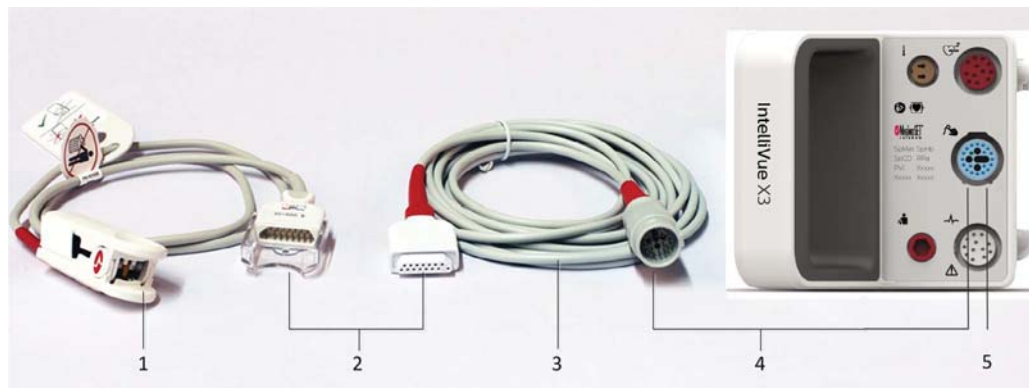

- 1 rainbow compatible sensor
- 2 Connection of the sensor and the adapter cable
- 3 Adapter cable
- 4 Connection of the adapter cable and the rainbow sensor socket
- 5 rainbow sensor socket

Masimo rainbow SET Measurements

To use the optional rainbow SET measurements with your device, activate the corresponding option. Set the label for SpO₂ to the standard SpO₂, and not to an alternative label for example to SpO₂po. Also enable the corresponding measurement in the SpO₂ menu.

To use the measurements SpCO, SpHb/SpOC, and SpMet, the sensor must support those measurements.

Understanding Numerics

Screen Layout Example

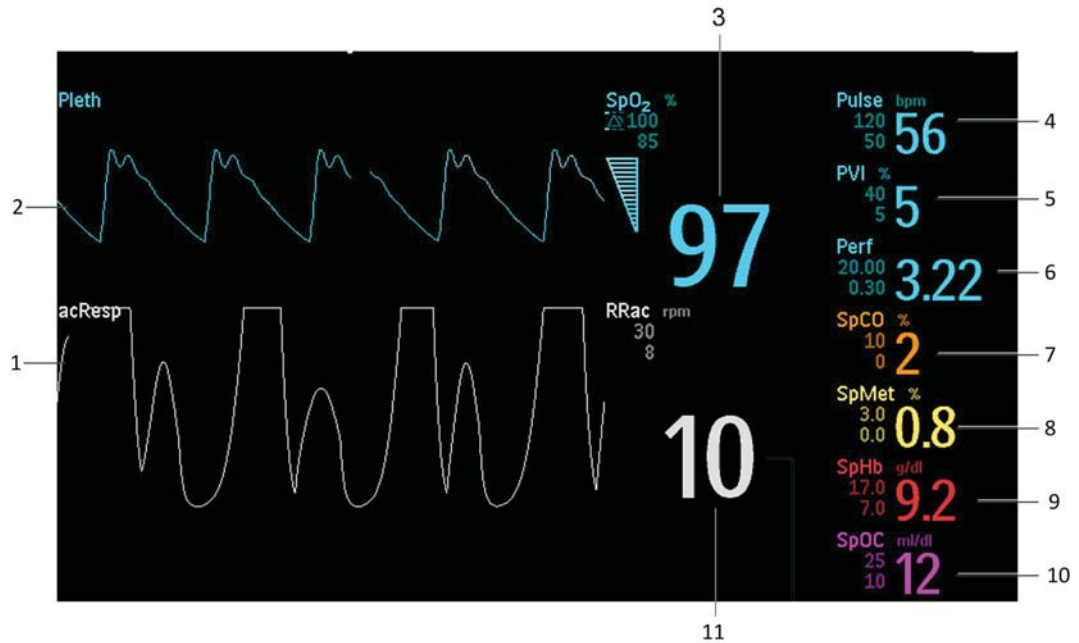

- 1 acResp wave
- 2 Pleth wave
- 3 SpO₂ label with unit, alarm limits, and numeric
- 4 Pulse label with unit, alarm limits, and numeric
- 5 PVI label with unit, alarm limits, and numeric
- 6 Perf label with alarm limits, and numeric
- 7 SpCO label with unit, alarm limits, and numeric
- 8 SpMet label with unit, alarm limits, and numeric
- 9 SpHb label with unit, alarm limits, and numeric
- 10 SpOC label with unit, alarm limits, and numeric
- 11 RRac label with unit, alarm limits, and numeric

The Masimo rainbow SET measurements can be set up and customized in Configuration and Monitoring Mode.

Measurement Modes

SpO₂ Sensitivity

The different sensitivity settings allow you to adapt the SpO₂ measurement sensitivity to the strength and quality of the SpO₂ signal at the measurement site.

Normal Sensitivity: This setting is recommended for patients who are experiencing some compromise in blood flow or perfusion. It is advisable for care areas where patients are observed frequently, such as an intensive care unit (ICU).

Adaptive Probe Off Detection (APOD) Sensitivity: This setting is recommended for care situations in which there is a high probability of the sensor becoming detached. It is also the suggested mode for care areas where patients are not visually monitored continuously. This mode delivers enhanced protection

against erroneous pulse rate and arterial oxygen saturation readings when a sensor becomes inadvertently detached from a patient due to excessive movement.

- 1 Select the **Setup SpO₂** menu.
- 2 Select **Sensitivity** from the menu.
- 3 Switch between **APOD** and **Normal**.

Maximum Sensitivity

Maximum sensitivity is recommended for use on patients with weak signals, for example, patients with very low perfusion, or in clinical environments with high ambient light.

- 1 Select the **Setup SpO₂** menu.
- 2 Select **Max. Sensitivity** from the menu.
- 3 Switch between **On** and **Off**
- 4 When you select **On** the prompt **Select Confirm to enable maximum sensitivity. Sensor off detection is compromised, attended monitoring recommended.** is issued.
- 5 Select **Confirm**.

Sensitivity will fall back to the configured sensitivity (**APOD** or **Normal**) after a patient is discharged. Also if the sensitivity mode is manually set to **APOD** or **Normal**, the maximum sensitivity falls back to **Off**. The Maximum sensitivity setting survives a short power interruption.

NOTE

When using the **Max. Sensitivity** setting, performance of the "Sensor Off" detection may be compromised. If the sensor is detached or falls off the patient, you may receive false readings due to environmental "noise" such as light, vibration, and excessive air movement (e.g. vents or ventilators).

FastSat

FastSat enables rapid tracking of arterial oxygen saturation changes. Arterial oxygen saturation data is averaged using averaging algorithms to smooth the trend. When **FastSat** is set to **On**, the averaging algorithm evaluates all the saturation values providing an averaged saturation value that is a better representation of the patient's current oxygenation status. With FastSat, the averaging time is dependent on the input signal.

- 1 Select the **Setup SpO₂** menu.
- 2 Select **FastSat Algor.** from the menu.
- 3 Switch between **On** and **Off**.

Setting Up 3D Desat Index Alarm

The configurable 3D Desat Index alarm is issued when a patient experiences a specified number of desaturations that exceed a specified threshold over a specific period of time.

- 1 Select the **Setup SpO₂** menu.
- 2 Select **3D Desat Index** from the menu.
- 3 Select if the **3D Desat Index** should be **On** or **Off**.
- 4 Set the **Delta Threshold** for the alarm between minimum 2% and maximum 10%, in steps of 1%.
- 5 Set the **Count** for the alarm between minimum 1 and maximum 25, in steps of 1.
- 6 Set the **Period** to the time duration for which the desaturations are counted. Select a minimum of 1 hour to a maximum of 4 hours, and in a step size of 1 hour.

NOTE

The 3D Desat Index restarts counting:

- when power is removed from the measurement device (for example, Multi-Measurement Module is moved to different monitor),
- the sensor, or patient cable is disconnected,
- or in the event of a **Sensor Off** condition.

Setting Up SpCO

The SpCO numeric reflects the carboxyhemoglobin saturation at the measurement location.

- 1 Select the **Setup SpO₂** menu.
- 2 Select **SpCO** from the menu.
- 3 Select if the **SpCO** measurement should be **Enabled** or **Disabled**.
- 4 Select if **Alarms** should be **On** or **Off** for the measurement.
- 5 Enter values for the **High Limit** and **Low Limit**.

**Setting Up SpMet**

The SpMet numeric reflects the methemoglobin saturation at the measurement location.

- 1 Select the **Setup SpO₂** menu.
- 2 Select **SpMet** from the menu.
- 3 Select if the **SpMet** measurement should be **Enabled** or **Disabled**.
- 4 Select if **Alarms** should be **On** or **Off** for the measurement.
- 5 Enter values for the **High Limit** and **Low Limit**.



Setting Up SpHb

The SpHb numeric reflects the total hemoglobin concentration at the measurement location.

- 1 Select the **Setup SpO₂** menu.
- 2 Select **SpHb / SpOC** from the menu.
- 3 Select if the **SpHb** measurement should be **Enabled** or **Disabled**.
- 4 Select if **SpHb Alarms** should be **On** or **Off** for the measurement.
- 5 Enter values for the **SpHb High Limit** and **SpHb Low Limit**.



NOTE

When the device is configured to show the level of total hemoglobin in arterial blood, the label is SpHb. Whereas the label is SpHbv, when the device is configured to show the level of total hemoglobin in venous blood.

Setting Up SpOC

The SpOC numeric reflects the total oxygen content at the measurement location. The SpOC numeric has to be enabled during configuration, and requires the SpHb measurement to be available. SpOC is calculated from SpO₂ and SpHb values.

- 1 Select the **Setup SpO₂** menu.
- 2 Select **SpHb / SpOC** from the menu.
- 3 Select if the **SpHb** measurement should be **Enabled** or **Disabled**. **SpOC** is only enabled when the **SpHb** measurement is **Enabled**.
- 4 Select if **SpOC Alarms** should be **On** or **Off** for the measurement.
- 5 Enter values for the **SpOC High Limit** and **SpOC Low Limit**.



SpHb Average

Depending on your configuration, you may be able to select the averaging period for SpHb in Monitoring Mode. The choices are **Short**, **Medium**, or **Long**. This setting adjusts the responsiveness of the SpHb measurement to make rapid variations of SpHb values more visible.

Setting Up PVI

The Pleth Variability Index (PVI) numeric may reflect physiological factors such as vascular tone, circulating blood volume, and intrathoracic pressure excursions. The PVI measurement takes 15 seconds.

- 1 Select the **Setup SpO₂** menu.
- 2 Select **PVI** from the menu.
- 3 Select if the **PVI** measurement should be **On** or **Off**.
- 4 Select if **Alarms** should be **On** or **Off** for the measurement.
- 5 Enter values for the **High Limit** and **Low Limit**.



Setting Up Perf

The Perf measurement is only available, if it is set to **On** during configuration.

- 1 Select the **Setup SpO₂** menu.
- 2 Select **Perf** from the menu.
- 3 Select if **Alarms** should be **On** or **Off**.
- 4 Enter values for the **High Limit** and **Low Limit**.



Setting up Perf Baseline

Select **Set Baseline** to update the Perf baseline. Setting the Perf baseline also turns on the **3D Perf Delta**. Whenever the perfusion baseline is set, the alarm active time is set automatically to the configured 3D Perf Delta **Duration**.

Setting up 3D Perf Delta

- 1 Select **3D Perf Delta** from the menu.
- 2 Select if the **3D Perf Delta** should be **On** or **Off**.
- 3 Enter a value for the **% Decrease** parameter.
- 4 Enter a value for the **Duration** the alarm should be active.

NOTE

The **3D Perf Delta** is switched off when the sensor is unplugged, or when a **Sensor Off** condition occurs, or when a patient is discharged. It will not be re-enabled automatically. The extended alarm text contains the maximum exceeded Perf Delta value.

Setting Up RRac

The RRac numeric reflects the respiration rate at the measurement location. SpO₂ monitoring is required when monitoring RRac.

- 1 Select the **Setup SpO₂** menu.
- 2 Select **RRac** from the menu.
- 3 Select if the **RRac** measurement should be **On** or **Off**.
- 4 Select if **Alarms** should be **On** or **Off** for the measurement.
- 5 Enter values for the **High Limit** and **Low Limit**.
- 6 Set the **Pause Time** from minimum 15 sec to maximum 40 sec, in steps of 5 sec. The **Pause Time** is the maximum time the measurement will wait between breaths of the patient before alarming.
- 7 Set the **Max.Extnd. Update** choosing from 0, 1, 5, 10, or 15 minutes.

The **Max.Extnd. Update** value determines the maximum amount of time the measurement displays the last known RRac value before the value becomes invalid. If it is set to a value other than 0, and the measurement cannot detect a respiration signal, there is no immediate indication (INOP issued) that the displayed status is an older one, and that currently no measurement is possible. If you do change the value, you are prompted to confirm your choice.



Monitoring NBP

This monitor uses the oscillometric method for measuring NBP.

The NBP measurement is suitable for use in the presence of electrosurgery and during the discharge of a cardiac defibrillator according to IEC 60601-2-30.

A physician must determine the clinical significance of the NBP information.

Introducing the Oscillometric NBP Measurement

Oscillometric devices measure the amplitude of pressure changes (oscillations) in the occluding cuff as the cuff deflates from above systolic pressure. The amplitude suddenly increases as the pulse breaks through the occlusion in the artery. As the cuff pressure decreases further, the pulsations increase in amplitude, reach a maximum (which approximates to the mean pressure), and then diminish.

Studies show that, especially in critical cases (arrhythmia, vasoconstriction, hypertension, shock), oscillometric devices are more accurate and consistent than devices using other noninvasive measuring techniques.

WARNING

Patient Category: Select the correct patient category setting for your patient. The higher adult/pediatric initial inflation pressures, overpressure limit and measurement duration may cause injury (hematoma) to neonatal patients. Further, blood pressure readings may be incorrect, if the selected patient category does not match the patient.

Intravenous infusion: Do not use the NBP cuff on a limb with an intravenous infusion or arterial catheter in place. This could cause tissue damage around the catheter when the infusion is slowed or blocked during cuff inflation.

Skin Damage: Do not measure NBP in cases of sickle-cell disease or any condition where skin damage has occurred or is expected.

Existing Wounds: Do not apply the cuff over a wound as this can cause further injury.

Mastectomy or Lymph Node Clearance: Avoid applying the cuff on the side of the mastectomy or lymph node clearance, as the pressure increases the risk of lymphedema. For patients with a bilateral mastectomy or lymph node clearance, use clinical judgement to decide whether the benefit of the measurement outweighs the risk.

Unattended Measurement: Use clinical judgement to decide whether to perform frequent unattended blood pressure measurements. Too frequent measurements can cause blood flow interference potentially resulting in injury to the patient. In cases of severe blood clotting disorders frequent measurements increase the risk of hematoma in the limb fitted with the cuff.

Temporary Loss of Function: The pressurization of the cuff can temporarily cause loss of function of monitoring equipment used simultaneously on the same limb.

CAUTION

If you spill liquid onto the equipment or accessories, particularly if there is a chance that it can get inside the tubing or the measurement device, contact your service personnel.

Measurement Limitations

NBP readings can be affected by the position of the patient, their physiological condition, the measurement site, and physical exercise. Thus a physician must determine the clinical significance of the NBP information.

Measurements are impossible with heart rate extremes of less than 40 bpm or greater than 300 bpm, or if the patient is on a heart-lung machine.

The measurement may be inaccurate or impossible:

- with excessive and continuous patient movement such as shivering or convulsions
- if a regular arterial pressure pulse is hard to detect with cardiac arrhythmias
- with rapid blood pressure changes
- with severe shock or hypothermia that reduces blood flow to the peripheries
- with obesity, where a thick layer of fat surrounding a limb dampens the oscillations coming from the artery
- on an edematous extremity.

The effectiveness of this sphygmomanometer has not been established in pregnant, including pre-eclamptic patients.

When the accelerated measurement is used the minimum number of oscillations per deflation step is 1, instead of the 2 in the standard measurement. This allows a faster measurement result but requires that the patient keeps the limb in question still. The accelerated measurement is recommended for use when very few or no artifacts are expected, for example with sedated patients.

You can see whether the accelerated measurement is in use by looking in the **Setup NBP** menu. The **Accelerated Msmt** setting shows whether the accelerated measurement is **Off**, on for **Manual** measurements or on for **All** measurements. You can see this setting in Monitoring Mode but it can only be changed in Configuration Mode.

When the accelerated measurement is in use, no pulse rate is derived from NBP.

Measurement Modes

There are three modes for measuring NBP:

- **Manual** - measurement on demand.
- **Auto** - continually repeated measurements (between one minute and 24 hours adjustable interval).
- **Sequence** - up to four measurement cycles which will run consecutively, with number of measurements and interval between them configurable for each cycle.

Auto and **Sequence** modes must be set up, before a measurement series can be started. See “[Enabling Automatic Mode and Setting Repetition Time](#)” on page 234 and “[Enabling Sequence Mode and Setting Up The Sequence](#)” on page 235.

Additionally, you have the possibility to start an immediate, one-time measurement series at any time:

- **STAT** - rapid series of measurements over a five minute period. Use only on supervised patients.

After a STAT measurement series, the monitor returns to the previous mode. If an **Auto** or **Sequence** measurement series was running before the STAT measurement, it will continue to run afterwards.

Reference Method

The measurement reference method can be Auscultatory (manual cuff) or Invasive (intra-arterial). For further information, see the Application Note supplied on the monitor documentation DVD.

In Neonatal mode, to comply with safety standards, invasive is always used as the reference method. This setting cannot be changed and is not visible in any operating mode.

In Adult and Pediatric mode, to check the current setting, select **Main Setup** then **Measurements** followed by **NBP**, and check whether the **Reference** setting is set to **Auscultatory** or **Invasive**. This setting can only be changed in Configuration Mode.

Preparing to Measure NBP

- 1 Connect the cuff to the air tubing.
- 2 Plug the air tubing into the red NBP connector. Avoid compression or restriction of pressure tubes. Air must pass unrestricted through the tubing.

WARNING

Kinked or otherwise restricted tubing can lead to a continuous cuff pressure, causing blood flow interference and potentially resulting in injury to the patient.

- 3 Make sure that you are using a Philips-approved correct sized cuff and that the bladder inside the cover is not folded or twisted.
A wrong cuff size, and a folded or twisted bladder, can cause inaccurate measurements. The width of the cuff should be in the range from 37% to 47% of the limb circumference. The inflatable part of the cuff should be long enough to encircle at least 80% of the limb.
- 4 Apply the cuff to a limb at the same level as the heart. If it is not, you must use the measurement correction formula to correct the measurement.
The marking on the cuff must match the artery location. Do not wrap the cuff too tightly around the limb. It may cause discoloration, and ischemia of the extremities.

WARNING

Inspect the application site regularly to ensure skin quality and inspect the extremity of the cuffed limb for normal color, warmth and sensitivity. If the skin quality changes, or if the extremity circulation is being affected, move the cuff to another site or stop the blood pressure measurements immediately. Check more frequently when making automatic or stat measurements.

Correcting the Measurement if Limb is not at Heart Level

To correct the measurement if the limb is not at heart level, to the displayed value

Add 0.75 mmHg (0.10 kPa) for each centimeter higher or	Deduct 0.75 mmHg (0.10 kPa) for each centimeter lower or
Add 1.9 mmHg (0.25 kPa) for each inch higher.	Deduct 1.9 mmHg (0.25 kPa) for each inch lower.

Recommendations For Measurements Used in Diagnosis of Hypertension

To make a measurement for use in the diagnosis of hypertension, follow the steps below:

- 1 Ensure the patient is comfortably seated, with their legs uncrossed, feet flat on the floor and back and arm supported.
- 2 Ask the patient to relax and not talk before and during the measurement.
- 3 If possible, wait 5 minutes before making the first measurement.

Understanding the NBP Numerics



- 1 Pulse numeric
- 2 Measurement Mode
- 3 Repetition Time
- 4 Timestamp/Timer
- 5 Mean pressure
- 6 Diastolic
- 7 Systolic
- 8 Alarm limits
- 9 Alarm source

Depending on the NBP numeric size, not all elements may be visible. Your monitor may be configured to display only the systolic and diastolic values. If configured to do so, the pulse from NBP will display with the NBP numeric.

The measured NBP value, together with the corresponding pulse rate if this is switched on, will be displayed for one hour. After that the values are regarded as invalid and are no longer displayed.

During this hour, measurement values may be grayed out or disappear from the screen after a set time, if configured to do so. This avoids older numerics being misinterpreted as current data. The time can be set in Configuration mode.

In **Auto** mode the measurement values may disappear more quickly (to be replaced by new measurement values), if the repeat time is set to less than one hour.

Alarm Sources

If you have parallel alarm sources, the sources are displayed instead of the alarm limits.

NBP Timestamp

Depending on your configuration, the time shown beside the NBP numeric can be:

- the time of the most recent NBP measurement, also known as the "timestamp", or
- the time until the next measurement in an automatic series, displayed with a graphic representation of the remaining time, as shown here.



The NBP timestamp will normally show the **completion** time of the NBP measurement. Only under the following conditions the timestamp shows the **beginning** of the measurement:

- when in **Auto** or **Sequence** mode, **and**
- the monitor is configured to synchronize the measurements in a measurement series to an "easy-to-document" time. For example, if you start the first measurement at 08:23, and the **Repeat Time** is set to 10 minutes, the monitor automatically performs the next measurement at 8:30, then 8:40 and so on.

During Measurements

The cuff pressure is displayed instead of the units and the repeat time. An early systolic value gives you a preliminary indication of the systolic blood pressure during measurement.



When Unexpected Values are Measured











When values measured are higher or lower than expected, check the following potential causes:

Possible Cause	Solution
The patient was talking or moving before or during the measurement.	Allow the patient to rest quietly, then try again after three to five minutes.
The incorrect cuff size was used or the cuff was not at heart level	Check the cuff size, level, and position then repeat the measurement.
The noninvasive blood pressure reference method is set incorrectly.	Check the reference method (auscultation or intra-arterial) in the Setup NBP menu. If it is incorrect, have it changed in Configuration Mode.
Measurement limitations have not been taken into account.	Check the list in "Measurement Limitations" on page 230.
NBP algorithm searching in wrong cuff pressure range. Artifacts during a previous measurement have falsified internal parameters of the algorithm (e.g. inflation pressure)	Press Stop All and start a NBP measurement or restart NBP measurement series. This resets the internal parameters of the NBP algorithm.
The standards for measuring NBP have not been adhered to.	Make sure you use the current standards to measure NBP.

Starting and Stopping Measurements

Use the Setup menu, SmartKeys or the Multi-Measurement Module hardkey to start and stop measurements.

Action to be performed	NBP Setup menu	SmartKeys	Multi-Measurement Module hardkey
Start manual measurement Start Auto series	Start/Stop	 Start/ Stop	Start/Stop
		 Start NBP	---

Action to be performed	NBP Setup menu	SmartKeys	Multi-Measurement Module hardkey
Start STAT measurement	NBP STAT	 NBP STAT	STAT (for Multi-Measurement Module without Pressure/Temp measurement)
		 Start STAT	
Stop Manual measurements	Start/Stop	 Start/ Stop	Start/Stop
		 Stop NBP	
Stop current Auto measurement	Start/Stop	 Start/ Stop	Start/Stop
		 Stop NBP	
Stop current STAT measurement and end series	Start/Stop	 Start/ Stop	Start/Stop
	NBP STAT	 NBP STAT	STAT (for Multi-Measurement Module without Pressure/Temp measurement)
		 Stop NBP	
Stop Auto, Manual or STAT measurement AND series	Stop All	 Stop All	

CAUTION

Use clinical judgment to decide whether to perform repeated series of STAT measurements because of the risk of purpura, ischemia and neuropathy in the limb with the cuff.

Enabling Automatic Mode and Setting Repetition Time

- 1 In the **Setup NBP** menu, select **Mode** and select **Auto** from the pop-up menu.
- 2 For an automatic measurement, select **Repeat Time** and set the time interval between two measurements.

Enabling Sequence Mode and Setting Up The Sequence

- 1 In the **Setup NBP** menu, select **Mode** and select **Sequence** from the pop-up menu.
- 2 Select **Setup Sequence** to open the **Setup Sequence** window.
Up to four measurement cycles can be set up which will run consecutively. For each cycle you can set the number of measurements and the interval between them. If you want to run less than four cycles in a sequence, you can set the number of measurements for one or more cycles to **Off**.
- 3 Select each sequence in turn and select the number of measurements and the time interval between the measurements.
- 4 To have measurements continue after the sequence, set the number of measurements for your last cycle to **Continuous** and this cycle will run indefinitely.

CAUTION

Be aware that, if none of the cycles are set to **Continuous**, NBP monitoring will end after the last measurement of the cycle.

When the NBP measurement mode is set to **Sequence**, the repetition time for **Auto** mode cannot be changed.

Choosing the NBP Alarm Source

You can monitor for alarm conditions in systolic, diastolic and mean pressure, either singly or in parallel. Only one alarm is given, with the priority of mean, systolic, diastolic.

In the **Setup NBP** menu, select **Alarms from** and choose from:

Menu option	Pressure value monitored
Sys.	systolic
Dia.	diastolic
Mean	mean
Sys & Dia	systolic and diastolic in parallel
Dia & Mean	diastolic and mean in parallel
Sys & Mean	systolic and mean in parallel
Sys&Dia&Mean	all three pressures in parallel

If **Mean** is not selected as alarm source (**Sys.**, **Dia.**, or **Sys & Dia** selected), but the monitor can only derive a mean value, mean alarms will nevertheless be announced using the most recent mean alarm limits. Check that the mean alarm limits are appropriate for the patient, even when not using mean as the alarm source. When no value can be derived an **NBP Measure Failed INOP** will be displayed.

Switching Pulse from NBP On/Off

In the process of making the NBP measurement, a pulse value can be derived and displayed. The pulse value is displayed together with the time the measurement was made. After one hour the value becomes invalid. There are no alarms associated with pulse from NBP.

When the accelerated measurement is in use, no pulse value can be derived.

To switch the display of the pulse value on or off:

- In the **Setup NBP** menu select **Pulse (NBP)**.

Assisting Venous Puncture

You can use the NBP cuff to cause subdiastolic pressure. The cuff deflates automatically after a set time (adult/pediatric 170 seconds, neonatal 85 seconds) if you do not deflate it.

- 1 In the **Setup NBP** menu select **VeniPuncture**.
- 2 Puncture vein and draw blood sample.
- 3 Reselect **VeniPuncture** to deflate the cuff.

During measurement, the NBP display shows the inflation pressure of the cuff and the remaining time in venous puncture mode.

NOTE

Performing a venous puncture while automatic or sequence NBP measurements are being made suspends the measurement series for the duration of the venous puncture inflation and for three minutes afterwards.

Calibrating NBP

NBP is not user-calibrated. NBP pressure transducers must be verified at least once every two years by a qualified service professional, and calibrated, if necessary. Refer to the Service Guide for more information.

Monitoring Temperature

WARNING

Measurements from **any** Measurement Extension connected to an X2, or from a **previous generation** Measurement Extension connected to an X3, are not available when the X2/X3 is running on its own battery power. They are only available when the X2/X3 is powered by external power: when connected to a host monitor, IntelliVue Dock or to the Battery Extension (865297).

You can measure temperature using an X1, X2, X3 or MMX Multi-Measurement Module, one of the Measurement Extensions, or the temperature plug-in module - labeled as TEMP in all languages.

Temp measurement automatically switches on when you connect a probe. You can switch the measurement off manually.

The displayed temperature is the temperature measured directly at the measurement site. No predictions or adjustments are made (direct mode thermometer).

Making a Temp Measurement

- 1 Select the correct type and size of probe for your patient.
- 2 If you are using a disposable probe, connect the probe to the temperature cable.
- 3 Plug the probe or temperature cable into the temperature connector socket.
- 4 Apply the probe to the patient. You are advised to use a protective rubber cover on rectal probes.
- 5 Select an appropriate temperature label.
- 6 Check that the alarm settings (on or off, high and low limits) are appropriate for this patient and this type of temperature measurement.

WARNING

Make sure you set alarm limits for the correct label. The alarm limits you set are stored for that particular label only. Changing the label may change the alarm limits.

Selecting a Temperature for Monitoring

Tell the monitor which temperature you want to monitor by selecting its temperature label. The label is a unique identifier for each type of temperature. When you choose a label, the monitor uses that label's stored color and alarm settings.

- 1 In the **Setup <Temp Label>** menu, select **Label**.
- 2 Select the appropriate label from the list.

Temp	non-specific temperature label	Trect	rectal temperature
Tart	arterial temperature	Tskin	skin temperature
Tcore	core temperature	Tven	venous temperature
Tesoph	esophageal temperature	Tnaso	nasopharyngeal temperature

Extended Temperature Label Set

The following additional labels are available if **Label Set** is set to **Full**. This setting can only be changed in Configuration Mode.

Note that if your monitor is connected to an Information Center, the additional labels in the extended label set may not be correctly displayed. See the Configuration Guide for your monitor for more information.

T1, T2, T3, T4	Non-specific temperature labels
Tamb	ambient temperature
Tbladd	bladder temperature
Tcereb	cerebral temperature
Tfoley	foley temperature
Ttymp	tympanic temperature
Tvesic	vesical temperature

Calculating Temp Difference

The monitor can calculate and display the difference between two temperature values by subtracting the second value from the first. The difference is labeled **ΔTemp**.

- 1 In the **Main Setup** menu, select **Measurements**.
- 2 Select **ΔTemp**.
- 3 In the **Setup ΔTemp** menu, select **First Temp**.
- 4 Select the appropriate label for the measurement source.
- 5 Select **Second Temp**.
- 6 Select the appropriate label for the second measurement source.

Measuring Tympanic Temperature

The tympanic thermometer measures the patient's temperature in the ear using infrared technology.



The result of this measurement can be automatically adjusted to correspond to a different body reference site. The result is displayed on the screen of the thermometer and transmitted to the monitor.

The tympanic thermometer is used with single-use probe covers for infection control during measurement.

WARNING

Do not use in the presence of flammable anesthetics, such as a flammable anesthetic mixture with air, oxygen or nitrous oxide.



- 1 Base station
- 2 Thermometer





Place the thermometer into its base station, when it is not in use. The base station allows flexible mounting of the thermometer at the point of care. The base station is connected via a cable to the monitor's measurement connector or MIB/RS232 interface. It has storage space for up to 32 probe covers.

Thermometer Display and Controls

The tympanic thermometer has a liquid crystal display. The display shows the patient's temperature in numerics and guides you with symbols through the measurement process.





- 1 Eject key
- 2 Change unit key: °Celsius / °Fahrenheit
- 3 Start measurement key
- 4 Pulse timer key

Functional Keys	Description of Use
	Press the eject key to eject the probe cover. The eject key symbol is shown on the display when a measurement has been taken and transmitted.
	Press the change unit key after a measurement to switch between °C and °F.
	Press the start measurement key when you are ready to take a patient's temperature.
	The pulse timer key can be used to time vital signs you take manually. Press and hold the pulse timer key to enter timer mode. Press the pulse timer key again to start the timer. The thermometer will issue a one beep at 15 seconds, two beeps at 30 seconds, three beeps at 45 seconds, and four beeps at 60 seconds.

Status Screens

The thermometer performs an internal test at every start-up to verify that the system components are functioning properly. It measures the ambient temperature. During start-up and measurement, the thermometer screens communicate the current status.

Images	Description
	Ambient Temperature above specified range
	Ambient Temperature below specified range
System errors	
	<p>System error 12 - there is a problem with the settings. Contact your service personnel to have them check the settings and reset them, if necessary.</p> <p>If the display shows any other system error, then reset the thermometer by picking up a probe cover. If the system error does not clear, contact your service personnel.</p>

Making a Temperature Measurement

WARNING

Inaccurate measurement results can be caused by:

- incorrect application of the thermometer.
- anatomical variations in the ear.
- build up of earwax in the ear.
- excessive patient movement during the measurement.
- absent, defective or soiled probe covers.
- probe covers other than the specified probe covers.



- 1 Ensure that the base station is connected via the appropriate cable to the connector on the monitor.
- 2 Remove the thermometer from the base station.
The thermometer is latched to the base station to avoid an accidental fall when the base station is moved. To pick up the thermometer from the base station move it slightly up and then lift it from the base station to release the latch.
- 3 Press the eject key on the thermometer to discard any probe cover that may have been left on the thermometer from a previous use.
- 4 Pick up a new probe cover from the container on the base station.
- 5 Inspect the probe cover to make sure it is fully seated (no space between cover and tip base) and there are no holes, tears, or wrinkles in the plastic film.
- 6 Check that the correct temperature label for the measurement site or required reference site is displayed: **iTrect**, **iToral**, **iTcore**, or **iTtym**.
- 7 Place the thermometer with the probe cover in the ear canal, sealing the opening with the probe tip. For consistent results, ensure that the probe shaft is aligned with the ear canal.
- 8 Press and release the start measurement key gently.
- 9 Wait until you hear the three beeps.
- 10 Remove the probe from the ear.
The temperature values are displayed both on the thermometer itself and on the connected monitor.



- 11 Press the eject key to eject the probe cover into a suitable waste receptacle.
- 12 Return the thermometer to the base station.

The thermometer switches to stand-by mode after 30 seconds when not used.

Possible INOPs

Images	Description
	Patient temperature above measurement range.
	Patient temperature below measurement range.

WARNING

- Never apply the probe to the patient when the thermometer is not connected to the base station.
- Always use a single-use probe cover with the tympanic thermometer to limit patient cross-contamination.
- Measurement errors or inaccurate readings may result when probe covers other than the specified probe covers are used (see “Tympanic Temperature Accessories” on page 460).
- Insert the probe slowly and carefully to avoid damage to the ear canal and the tympanic membrane.
- Inspect the probe for damage, holes, tears, or sharp edges to avoid injuring the skin.
- Always ensure that the used probe cover is removed from the tympanic thermometer before picking up a new probe cover.

CAUTION

- Do not immerse the probe in fluids, or drop fluids on the probe.
- Do not use a probe that has been dropped or is damaged.
- Do not autoclave. To prevent damage to the base station, probe and accessories, refer to the cleaning procedures in the chapter.

WARNING

If you have dropped the base station or thermometer, or if the unit has been stored below -25°C or above 55°C , have service personnel test the unit for proper functions and calibrate the unit before further use.

Body Reference Sites and Monitor Labels

The tympanic thermometer measures the patient's temperature in the ear. The thermometer can be configured to adjust the result of the measurement to correspond to a different body reference site. The

12 Measuring Tympanic Temperature

measurement label displayed on the monitor corresponds to the body reference site that is configured. The following body reference sites are available:

Body Reference Site	Label on Monitor
Ear temperature (no adjustment)	iT_{tymp}
Oral temperature	iT_{oral}
Core temperature	iT_{core}
Rectal temperature	iT_{rect}

The body reference site can only be configured in the Biomed mode of the tympanic thermometer. Refer to the Service Guide for more information.

Monitoring Invasive Pressure

WARNING

Measurements from **any** Measurement Extension connected to an X2, or from a **previous generation** Measurement Extension connected to an X3, are not available when the X2/X3 is running on its own battery power. They are only available when the X2/X3 is powered by external power: when connected to a host monitor, IntelliVue Dock or to the Battery Extension (865297).

CAUTION

Do not use a monitor with an M1006A pressure module as an additional monitor for your patient. This may cause interference on the respiration or invasive pressure measurements.

You can measure pressure using an X1, X2, X3 or MMX Multi-Measurement Module, one of the Measurement Extensions or the pressure plug-in module (labeled as PRESS in all languages). With the plug-in module you may see a wave channel before the pressure cable is plugged in - with the Multi-Measurement Module this will not be the case.

The pressure measurement in the X3, MMX and the current generation Measurement Extensions is a dual pressure measurement. With one pressure connector, two pressures can be measured. To measure two pressures, you need a dual pressure cable. See the chapter of the X3 Instructions for Use for details. When the current generation Measurement Extensions are connected to an X1 or X2, only one pressure channel is available.

The two arms of the dual pressure cable are marked for identification with one ring and two rings. In the **Measurement Selection** window, the two pressure connectors are shown overlapping. When you select one of the labels, a symbol is displayed showing one bar or two bars, corresponding to the arm of the dual pressure cable that the pressure transducer is connected to.

If you connect a transducer without using a dual pressure cable or adapter, only one pressure can be measured.

If you connect a dual pressure cable to a pressure plug-in module, or to an X1 or X2 Multi-Measurement Module or previous generation extension that does not provide a dual pressure measurement, only one pressure can be measured. The source of that measurement is the pressure transducer connected to the arm of the cable marked with one ring.

The X3, MMX and the current generation Measurement Extensions can be used in companion mode with IntelliVue patient monitors with software revision \geq J.0. However, the dual pressure measurement is only available with host monitors with software revision M.0 or higher.

CAUTION

Do not use dual pressure cables with the X3, MMX or a current generation Measurement Extension if you are planning on using them in companion mode with a host monitor with software revision <M.0. If you use an X3, MMX or a current generation Measurement Extension in companion mode with a host monitor with software revision <M.0, the second dual pressure channel (labeled "II" on the Cable) will be deactivated.

Setting up the Pressure Measurement

- 1 Plug in the pressure cable.
- 2 Prepare the flush solution.
- 3 Flush the system to exhaust all air from the tubing. Ensure that the transducer and stopcocks are free of air bubbles.

WARNING

If air bubbles appear in the tubing system, flush the system with the infusion solution again. Air bubbles may lead to a wrong pressure reading.

- 4 Connect the pressure line to the patient catheter.
- 5 If you are using an infusion pressure cuff with the pressure line, attach the pressure cuff to the fluid to be infused. Inflate it according to your standard hospital procedure, then start the infusion.
- 6 Position the transducer so that it is level with the heart, approximately at the level of the midaxillary line.

WARNING

If measuring intracranial pressure (ICP, IC1 or IC2) with a sitting patient, level the transducer with the top of the patient's ear. Incorrect leveling may give incorrect values.

Selecting a Pressure for Monitoring

Tell the monitor the source of the pressure you want to monitor by selecting an appropriate pressure label. The label is a unique identifier for each type of pressure. When you choose a label, the monitor uses that label's stored settings, for example color, wave scale and alarm settings. The label also determines which algorithm is used to process the pressure signal, so an incorrect label can lead to incorrect pressure values.

- 1 In the **Setup <Press Label>** menu, select **Label**.
- 2 Select the appropriate label from the list.

Label	Description
ABP	Arterial blood pressure
ART	Arterial blood pressure (alternative)
Ao	Aortic pressure
CVP	Central venous pressure
ICP	Intracranial pressure
LAP	Left atrial pressure

Label	Description
P	Non-specific pressure label
PAP	Pulmonary artery pressure
RAP	Right atrial pressure
UAP	Umbilical arterial pressure
UVP	Umbilical venous pressure

Extended Pressure Label Set

The following additional labels are available if **Label Set** is set to **Full**. This setting can only be changed in Configuration Mode.

Note that if your monitor is connected to an Information Center, the additional labels in the extended label set may not be correctly displayed. See the Configuration Guide for your monitor for more information.

Label	Description
BAP	Brachial arterial pressure
FAP	Femoral arterial pressure
IC1, IC2	Alternative intracranial pressures
P1, P2, P3, P4	Alternative non-specific pressure labels
IAP	Intra-abdominal pressure
RFP	Right femoral arterial pressure
LFP	Left femoral arterial pressure
SCP	Spinal cord pressure
UBP	Urinary bladder pressure
Ppr	Pressure pre
Ppo	Pressure post
Pa1, Pa2, Pa3, Pa4	Alternative non-specific arterial pressure labels
Pv1, Pv2, Pv3, Pv4	Alternative non-specific venous pressure labels

Overview of Calibration Procedures

Calibration requirements depend on the situation and the type of transducer used. Recommendations for the different calibration procedures are given in the table below.

Procedure	When to perform	For which transducers?	
		Disposable	Reusable
Zero	<ul style="list-style-type: none"> • Every time you use a new or a different transducer or tubing • Every time you reconnect the transducer to the monitor • If you think the monitor's pressure readings are not correct 	X	X
Calibration	<ul style="list-style-type: none"> • Every time you use a new or a different transducer • According to your hospital policy 		X
Adjust calibration factor	<ul style="list-style-type: none"> • Can be done instead of the calibration procedure when a calibration factor is marked on your reusable transducer 		X

Zeroing the Pressure Transducer

To avoid inaccurate pressure readings, the monitor requires a valid zero. Zero the transducer in accordance with your hospital policy. You must perform a zero:

- when you use a new transducer or tubing
- every time you reconnect the transducer cable to the monitor
- if you think the monitor's pressure readings are not correct.

When using a pressure module, the zero information is stored in the module. When a pressure module, with the transducer connected, is plugged into the monitor, the monitor will use the zero stored in the module.

Zeroing ICP (or IC1/IC2) and SCP

Your hospital guidelines may require you to zero the ICP and SCP transducer less frequently than other transducers, due to the need for aseptic conditions. When you zero an ICP or SCP transducer, the zero values are automatically stored and you will not be prompted to repeat the zero procedure.

If you want to simultaneously zero all pressures except ICP and SCP, disconnect the ICP and SCP transducer from the Multi-Measurement module or pressure module while zeroing. Reconnecting the transducer recalls the stored values.

WARNING

If you select the label ICP (or IC1/IC2) or SCP, the measurement device uses the most recently stored zero. Therefore, make sure you zeroed the transducer correctly in accordance with the transducer manufacturer's instructions and your hospital policy. When you use a transducer that you cannot rezero after placement, ensure that you keep the measuring device with the patient so that you are certain you have the correct zero data for this patient.

Determining a Pressure's Most Recent Zero

The monitor displays a message with the most recent zero. If this has "timed-out" after you have performed a zero, redisplay the information by entering the pressure's setup menu.

Zeroing a Pressure Measurement

WARNING

Invasive pressure alarms (and pulse alarms, if derived from invasive pressure) are temporarily suppressed until 30 seconds after the transducer finishes zeroing.

- 1 Turn off the stopcock to the patient.
- 2 Vent the transducer to atmospheric pressure, to compensate for the static and atmospheric pressure exerted on the transducer.
- 3 In the setup menu for the pressure, select **Zero <Press Label>**.
- 4 When you see the message **<Press Label> zero done at <Date and Time>** on the screen, close the stopcock to atmospheric pressure, and open the stopcock to the patient.

CAUTION

When using high frequency ventilation, ensure that the tubing from the ventilator does not touch the arterial line, or connect with it indirectly, while zeroing the pressure. This could cause small pressure variations which can interfere with the zero procedure.

Using the Zero Hardkey

Pressing the Zero hardkey for two seconds on the M1006B Pressure module starts a zero for the pressure currently measured with the module. Depending on your language, the Zero hardkey on the module may be labeled **→0←**.

Pressing the Zero hardkey for two seconds on the M3001A/M3001AL Multi-Measurement module or the MMX Multi-Measurement Module zeros the pressure being measured by the Multi-Measurement module **and** the pressures from any connected Measurement Extensions.

Zeroing All Pressures Simultaneously

WARNING

Before zeroing all pressures, make sure that **all** pressure transducers are vented to atmospheric pressure.

If you are measuring pressures with more than one measuring device, using the **Zero Press** SmartKey to initiate the zeroing calls up a list of all active pressures. Select the pressure you want to zero or select **All Press** to zero all pressures simultaneously.

Troubleshooting the Zero

The status line lists the probable cause of an unsuccessful zero:

Message	Corrective Action
unable to zero – equipment malfunction	The hardware is faulty. Contact your service personnel.
unable to zero – excessive offset unable to zero – unstable signal	Make sure the transducer is vented to air and try again. If this fails, the hardware may be faulty. Replace the adapter cable and try again. If it fails, replace the transducer and try again. If it still fails, contact your service personnel.

Message	Corrective Action
unable to zero – no transducer	Make sure that the transducer is connected and try again. If this fails, exchange the adapter cable and try again. If this fails, exchange the transducer.
unable to zero – pulsatile pressure	Make sure that the transducer is vented to air, not to the patient, and try again.
unable to zero – timed out	Try pressing the Zero hardkey or Zero <Press Label> key again. If this fails, replace the transducer and adapter cable and contact your service personnel.
Switch <Press Label> on first	Pressure measurement is switched off. To switch it on, in the Setup <Press Label> menu, select the pressure's label.

Calibrating Reusable Transducers

Depending on your monitor's configuration, you may be able to perform a calibration in monitoring mode. Perform a mercury calibration when you use a new transducer, and at regular intervals according to your hospital policy. You require:

- standard sphygmomanometer.
- sterile 10cc syringe with heparinised solution.
- 3-way stopcock.
- approximately 25 cm of tubing.

NOTE

Only reusable transducers must be calibrated.

Making the Pressure Calibration

WARNING

Never perform the invasive pressure calibration while a patient is being monitored.

- 1 Zero the transducer.
- 2 Connect the syringe and manometer.
 - a. Attach the tubing to the manometer.
 - b. Connect the 3-way stopcock to the stopcock that is not connected to the patient catheter when you measure a patient.
 - c. Attach the syringe to one port and the manometer tubing to the other port.

- d. Open the port to the manometer.

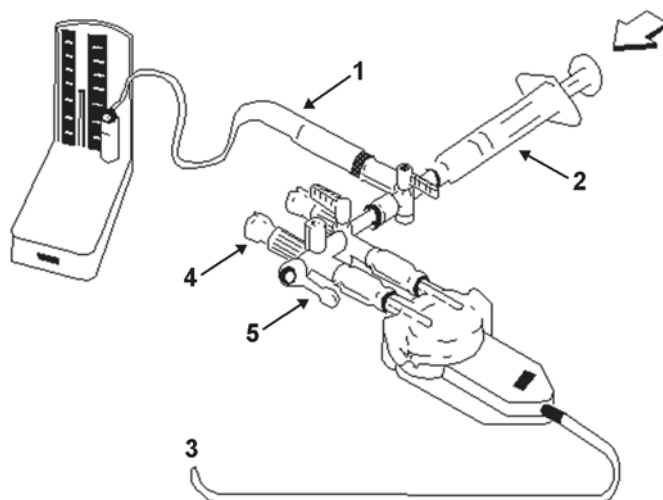

- 1 Tubing to manometer
 2 Syringe with heparinised solution
 3 To pressure connector on monitor
 4 Patient connection stoppered
 5 Off

- 3 Move the syringe plunger in and raise the mercury to 200 mmHg (30 kPa). 200 mmHg is the recommended calibration pressure.
- 4 In the **Setup <Press Label>** menu, select **Cal. Press**.
- 5 Select the calibration pressure from the list, for example 200 mmHg.
- 6 Select **Confirm** to recalculate the calibration factor using the applied pressure.
- 7 When the monitor displays **<Press Label> mercury calibr. done at <Date and Time>**, remove the manometer tubing, syringe and extra stopcock. We recommend you replace the transducer dome and tubing with sterile ones.
- 8 Label the transducer with the calibration factor shown in the **Cal. Factor** field in the pressure's setup menu.
- 9 Reconnect the patient and start measuring again.

Troubleshooting the Pressure Calibration

The status line lists the probable cause of an unsuccessful calibration.

Message	Corrective Action
unable to calibrate – equipment malfunction	Contact your service department. The pressure hardware is faulty.
unable to calibrate – out of range	Make sure that you have selected the value for Cal. Press that you are applying to the transducer, and repeat the calibration.
unable to calibrate – no transducer	Make sure that the transducer is connected and try again.
unable to calibrate – unstable signal	Make sure there are no disturbances to the transducer, and repeat the calibration.
unable to calibrate – perform zero first	No valid zero. Zero the transducer.

Adjusting the Calibration Factor

Each time you use a reusable transducer, compare the calibration factor written on your transducer with the calibration factor shown on the monitor. To ensure accurate measurement, they **must** be the same.

- 1 In the **Setup <Press Label>** menu, select **Cal. Factor**.
If the value here does **not** match that on the transducer, select the corresponding value from the list, in accordance with your hospital's procedure.
- 2 To confirm you want to use the new calibration factor, select the **Confirm** pop-up key.

Displaying a Mean Pressure Value Only

Use this when you want to see only the mean pressure.

In the pressure's setup menu, select **Mean only**. Toggle between **On** to display mean pressure value only, and **Off** to display all pressure values (systolic, diastolic and mean).

Changing the Pressure Wave Scale

- 1 Select the label of the pressure wave whose scale you want to set to enter the **Setup <Press Label>** menu.
- 2 In the **Setup <Press Label>** menu, (for example **ABP**) select **Scale**.
- 3 Select a value from the pop-up list:
 - a positive value sets the top gridline. The bottom gridline is set at zero.
 - a negative value sets the bottom gridline. The middle gridline is set at zero.

Optimizing the Waveform

In the **Setup <Press Label>** menu, select **Optimum Scale** to let the monitor select the best minimum and maximum scales for the current wave.

Using the Wave Cursor

When the pressure wave is selected, you can display a cursor in the wave. It appears as a white horizontal line in the wave. Using the pop-up keys you can move the cursor up or down to the required position and store the corresponding value. The cursor value can be stored

- as a systolic, diastolic or mean pressure value,
- as an IAP (intra-abdominal pressure) value - for the waves P, P1 to P8, if IAP is configured as a measurement which can be manually entered
- as a PAWP value - if the pressure wave is a PAP wave

The stored value appears in the trend database as a manually entered value.

To display and position the cursor,

- 1 Select the pressure wave.
- 2 Select **Activate Cursor**.
- 3 Use the pop-up arrow keys to position the cursor.

Using the pop-up keys you can also change the scale or the speed for the wave, freeze the wave or start a printout or recording.

Non-Physiological Artifact Suppression

Some clinical procedures may affect blood pressure, for example, a flush procedure or a blood sample. Your monitor may be configured to suppress these non-physiological artifacts for a specified duration (**Artifact Suppr.** is configured to **30 sec**, **60 sec**, or **90 sec**). During artifact suppression, the monitor shows the INOP message **<Press Label> Artifact**, and a question mark is shown beside the pressure numerics. Pressure alarms and the **<Press Label> No Pulse** INOP are suppressed during the configured period. The CPP alarms are not suppressed.

Choosing the Pressure Alarm Source

WARNING

Make sure you set alarm limits for the correct label. The alarm limits you set are stored for that particular label only. Changing the label may change the alarm limits.

You can monitor for alarm conditions in systolic, diastolic and mean pressure, either singly or in parallel. Only one alarm is given at a time, in this order of priority: mean, systolic, diastolic.

In the **Setup <Press Label>** menu, select **Alarms from** and choose the source.

Menu option	Pressure value monitored
Sys.	systolic
Dia.	diastolic
Mean	mean
Sys & Dia	systolic and diastolic in parallel
Dia & Mean	diastolic and mean in parallel
Sys & Mean	systolic and mean in parallel
Sys&Dia&Mean	all three pressures in parallel

Select and set the **High Limit** and **Low Limit** for the pressure(s) you have selected.

Extreme Alarm Limits for Pressure

The extreme pressure alarms, Extreme High and Extreme Low, can be made available for your monitor in Configuration Mode and are additional to the standard High and Low limit alarms. They are generated by the active pressure alarm source, and are setup in Configuration Mode by adding a set value (the Δ value) to the high and low alarm limits. This value can be set for each pressure label individually.

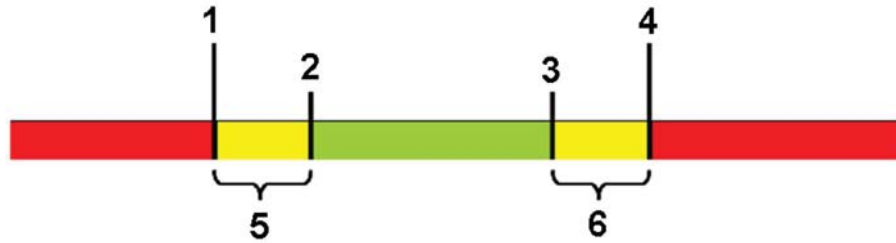

- 1 Extreme Low Limit
- 2 Low Limit
- 3 High Limit
- 4 Extreme High Limit
- 5 Δ Extreme Low
- 6 Δ Extreme High

You need to know which values have been configured for your monitor. Changing the high and low alarm limits automatically changes the extreme alarm limits within the allowed range.

- To see the extreme pressure alarms set for your monitor, in the **Setup <Press Label>** menu, see the menu items **Δ Extreme High** and **Δ Extreme Low**.

The extreme pressure alarms are high priority, red alarms, marked ******* in the alarm message.

Calculating Cerebral Perfusion Pressure

The monitor can calculate the difference between mean arterial pressure and the intracranial pressure. The difference is labeled CPP.

- 1 In the **Main Setup** menu, select **Measurements**.
- 2 Select **CPP**.
- 3 In the **Setup CPP** menu, select which arterial pressure source should be used in the calculation.

Calculating Pulse Pressure Variation

The Pulse Pressure Variation functionality in the X2 Multi-Measurement Module is not available in the USA and other territories relying on FDA market clearance.

Pulse Pressure Variation can be calculated in two different ways on this monitor - directly from the pressure measurement or in conjunction with the CCO measurement. Refer to the Cardiac Output chapter for information on PPV from CCO. Only one PPV can be active at a time.

Pulse Pressure Variation (PPV) is calculated from beat-to-beat arterial pressure values. Pulse pressure is the difference between the systolic and the diastolic pressure values for a single beat. Pulse pressure variation is defined as the maximal pulse pressure less the minimum pulse pressure, divided by the average of the two. The average variation in pulse pressure is calculated over periods of 32 seconds.

WARNING

- This monitor can calculate PPV from beat-to-beat values of any arterial pulsatile pressure. The circumstances under which the calculation of a PPV value is clinically meaningful, appropriate and reliable must be determined by a physician.
- The clinical value of the derived PPV information must be determined by a physician. According to recent scientific literature, the clinical relevance of PPV information is restricted to sedated patients receiving controlled mechanical ventilation and mainly free from cardiac arrhythmia.
- PPV calculation may lead to inaccurate values in the following situations:
 - at respiration rates below 8 rpm
 - during ventilation with tidal volumes lower than 8 ml/kg
 - for patients with acute right ventricular dysfunction ("cor pulmonale").
- The PPV measurement has been validated only for adult patients

To select an arterial pressure as PPV source:

- 1 In the **Main Setup** menu, select **Measurements**.
- 2 In the **Setup PPV** menu, select **ABP, ART, Ao, BAP, P, FAP, RFP, LFP, Ppr, Pa1, Pa2, Pa3** or **Pa4** as the arterial pressure source.

CAUTION

Older Multi-Measurement modules cannot supply a beat-to-beat arterial pressure value. In this case the monitor shows a **No PPV from MMS** or **No PPV from FMS INOP**.

Availability of PPV

As with other measurements, PPV can be switched on and off by selecting **PPV** in its setup menu. When switched off, PPV will no longer be calculated and displayed.

For PPV you have additionally the possibility to disable the PPV measurement by selecting **Measurement** in the PPV setup menu. The two settings are **Enabled** and **Disabled**. When the PPV measurement is disabled, it no longer appears in the **Measurement Selection** window and will not cause conflicts when PPV from CCO is used.

Measuring IAP

There are three methods to store IAP measurement readings in the monitor: continuous IAP measurement, with manual entry or using a pressure waveform.

NOTE

For continuous IAP measurements, manual entry for IAP must be deactivated in Configuration Mode and the continuous IAP must be activated. For the other two methods, to be able to use the label IAP, it must be made available for manual entry in Configuration Mode and the continuous IAP must be deactivated. For more details on manually entered measurements, see [“Entering Measurements Manually”](#) on page 56.

Continuous IAP Measurement

For continuous IAP measurements follow the instructions in [“Setting up the Pressure Measurement”](#) on page 246 and select the IAP label from the extended pressure label set.

Manual Entry

This method uses a reading from an independent IAP measurement device, for example a bladder manometer; the user manually transcribes the IAP reading to the monitor.

To manually enter the measured IAP value:

- 1 Select the IAP numeric on the screen.
- 2 Enter the IAP value and select **Enter** using the numeric keypad.
- 3 If you need to change date and time, select **Date/Time**. The default is always the current date and time. Select **Enter** to confirm.
- 4 Select **Save**.

Using a Pressure Waveform

This method uses an electronic reading from a pressure transducer connected to the monitor. The pressure transducer usually acquires the IAP from a dedicated IAP measurement device.

To enter the IAP using a connected IAP measurement device:

- 1 Assign the pressure label P (or P1...P8) to the pressure channel connected to the IAP transducer.
- 2 Zero the transducer as described in [“Zeroing a Pressure Measurement” on page 249](#).
- 3 Perform the IAP measurement according to the instructions given by the manufacturer of the IAP measurement device.
- 4 On the monitor screen, when the IAP pressure has stabilized, select the pressure waveform and select **Activate Cursor**.
- 5 Use the arrow up/down keys to move the wave cursor to an area of the waveform that reflects the correct pressure. See [“Using the Wave Cursor” on page 252](#) for details.
- 6 Select **Save as IAP**. This will store the IAP pressure value under the cursor in the monitor’s database and display it on the monitor screen.

Measuring Pulmonary Artery Wedge Pressure

Pulmonary Artery Wedge Pressure (PAWP) values, used to assess cardiac function, are affected by:

- Fluid status
- Myocardial contractility
- Valve and pulmonary circulation integrity

Obtain the measurement by introducing a balloon-tipped pulmonary artery flotation catheter into the pulmonary artery. When the catheter is in one of the smaller pulmonary arteries, the inflated balloon occludes the artery allowing the monitor to record changes in the intrathoracic pressures that occur throughout the respiration cycle. The pulmonary wedge pressure is the left ventricular end diastolic pressure (preload).

The most accurate PAWP values are obtained at the end of the respiration cycle when the intrathoracic pressure is fairly constant. You can use the respiration waveform as a reference when assessing the PAWP waveform, to ensure constant measurement timing relative to the respiratory cycle. The monitor displays the PAWP value for up to 24 hours or until you admit a new patient.

WARNING

The **pressure receptor** in the catheter records pressure changes that occur only in front of the occlusion. Even though the catheter tip is in the pulmonary artery, the receptor records pressure changes transmitted back through the pulmonary circulation from the left side of the heart.

While performing the wedge procedure, the monitor switches off the pressure alarms for pulmonary artery pressure (PAP).

Due to a slight measurement delay, you should not use sidestream CO₂ as a direct reference for determining the end expiratory point in the pressure curve.

To start the Wedge procedure,

- 1 In the **Main Setup** menu, select **Wedge** to display the wedge procedure window.
- 2 Prepare and check the pressure line according to your hospital policy.
- 3 Use the **Reference Wave 1** and **Reference Wave 2** pop-up keys to select any ECG or respiratory wave as reference waves.
- 4 Select **Change Speed** if you want to change the speed of the displayed wave. The speed can also be changed in the screen for editing the wedge.
- 5 Select **Change Scale** to change the wave scale of the PAP. The same scale will be used in the screen for editing the wedge. If the setting **Optimum Scale** is used, the wave scale will be optimized when a wedging waveform is recognized and will revert to the previous scale when the wedge procedure window is closed.
- 6 Inflate the balloon when the monitor prompts you: **Ready for balloon inflation**. The waveform changes from the PAP to the PAWP wave. The measurement takes approximately 12 seconds. On completion, the monitor stores the PAWP waveform display and prompts you to deflate the balloon. If the monitor cannot detect a wedging waveform you must use **Store Trace** to store the wedge and two reference waves manually.
- 7 Deflate the balloon when the monitor prompts you: **Ready for balloon deflation** and verify that the waveform returns to pulmonary artery shape.
- 8 If you need to start a new measurement, select **Restart Wedge**.

Editing the Wedge

- 1 Select the **Edit Wedge** pop-up key to see the stored waveforms.
- 2 The monitor displays a cursor in the waveform at the PAWP mean value. It also displays any previously stored value and the time it was stored.
- 3 Select **Change Speed** if you want to change the speed (resolution) of the displayed wave.
- 4 Move the cursors up, down, right and left to set them on the correct wedge position.
- 5 Select **Store Wedge** to store the PAWP value.
- 6 Select **Print Wedge** to print the PAWP waveform and any reference waves or **Record Wedge** to record them. While recording or printing, you cannot perform any more Wedge tasks.

WARNING

Prolonged inflation can cause pulmonary hemorrhage, infarction or both. Inflate the balloon for the minimum time necessary to get an accurate measurement.

If the pulmonary artery flotation catheter drifts into the wedge position without inflation of the balloon, the pulmonary artery pressure waveform assumes a wedged appearance. Take appropriate action, in accordance with standard procedures, to correct the situation.

If the PAWP (mean) is greater than the PAP (systolic), deflate the balloon and report the incident in accordance with hospital policy, because the pulmonary artery could be accidentally ruptured, and the wedge value derived will not reflect the patient's hemodynamic state, but will merely reflect the pressure in the catheter or balloon.

Identifying the Pressure Analog Output Connector



- 1 Analog output (module M1006B, option C01 only)

The analog pressure output signal can be used, for example, with intra-aortic balloon pumps (IABP). Use the output only with external devices that comply with IEC 60601-1.

Monitoring Cardiac Output

The Cardiac Output (C.O.) measurement invasively measures cardiac output and other hemodynamic parameters using a technique called thermodilution. This can be used to determine the flow rate of a system by introducing a cold solution into the system and measuring the resulting drop in temperature at a downstream site. The temperature change is displayed as a curve in the C.O. procedure window, and the monitor calculates the C.O. value from this curve. The C.O. value is inversely proportional to the area under the curve. As cardiac output varies continuously, a series of measurements must be carried out to achieve a reliable C.O. average value. Always use the average of multiple thermodilution measurements for therapy decisions.

The measurements can be carried out using the right heart thermodilution method or the PiCCO method (transpulmonary thermodilution).

- The right heart method is available with
 - C.O. module M1012A standard- labeled as C.O. in all languages, and option #C10 - labeled as CCO/C.O. in all languages.
 - M3012A Hemodynamic Measurement Extension Module, options #C05 and #C10
 - 867039 Hemodynamic Measurement Extension Module, options #B05 and #B10
 - M3014A Capnography Measurement Extension Module, option #C05 and #C10
 - 867040 Capnography Measurement Extension Module, option #B05 and #B10
 - 867041 Microstream Capnography Measurement Extension Module, option #B05 and #B10
- The PiCCO method is available with
 - C.O. module M1012A option #C10 - labeled as CCO/C.O. in all languages
 - M3012A Hemodynamic Measurement Extension Module, option #C10
 - 867039 Hemodynamic Measurement Extension Module, option #B10
 - M3014A Capnography Measurement Extension Module, option #C10
 - 867040 Capnography Measurement Extension Module, option #B10
 - 867041 Microstream Capnography Measurement Extension Module, option #B10

The PiCCO method additionally lets you measure Continuous Cardiac Output (CCO) by performing pulse contour analysis on the blood pressure waveform.

The Cardiac Output Options 867040 #B10 and 867041 #B10 are not available in the USA and other territories relying on FDA market clearance.

Hemodynamic Parameters

This table illustrates the hemodynamic parameters available with each method, whether they are measured continuously, and whether they can be shown on the monitor's main screen or in the **Hemodynamic Calculations** window.

14 Monitoring Cardiac Output

Measured and Calculated Hemodynamic Parameters and Indexes	PiCCO Method (Transpulmonary Thermodilution)			Right Heart Thermodilution		
	Continuous?	Main Screen	HemoCalc Window	Continuous?	Main Screen	HemoCalc Window
Blood Temperature (Tblood)	Yes	Yes	No	Yes	Yes	No
C.O./C.I.: Cardiac Output	No	Yes	Yes	No	Yes	Yes
CCO/CCI: Continuous Cardiac Output	Yes	Yes	Yes (in the C.O. field)	Not available		
CPO/CPI: Cardiac Power Output	Yes	Yes	Yes	Not available		
SVR/SVRI: Systemic Vascular Resistance	Both	Yes	Yes	No	No	Yes
SV/SI: Stroke Volume/SV Index	Both	Yes	Yes	No	No	Yes
SVV: Stroke Volume Variation	Yes	Yes	Yes	Not available		
*dPmax: Left Ventricular Contractility Index	Yes	Yes	Yes	Not available		
CFI: Cardiac Function Index	No	Yes	Yes	Not available		
PPV: Pulse Pressure Variation	Yes	Yes	Yes	Not available		
ITBV/ITBVI: Intrathoracic Blood Volume	No	Yes	Yes	Not available		
EVLW/EVLWI: Extravascular Lung Water	No	Yes	Yes	Not available		
GEDV/GEDVI: Global End-Diastolic Volume	No	Yes	Yes	Not available		
*PVPI: Pulmonary Vascular Permeability Index	No	Yes	Yes	Not available		
*GEF: Global Ejection Fraction	No	Yes	Yes	Not available		
*RLShnt: Right-Left-Shunt Fraction	No	No	No	Not available		
PVR/PVRI: Pulmonary Vascular Resistance	Not available			No	No	Yes
LCW/LCWI: Left Cardiac Work	No	No	Yes	No	No	Yes
RCW/RCWI: Right Cardiac Work	Not available			No	No	Yes
RVSW/RVSWI: Right Ventricular Stroke Work	Not available			No	No	Yes

* currently not available in the U.S.A. and territories relying on FDA market clearance.

NOTE

EVLWI is calculated using Ideal Body Weight (IBW). ITBVI and GEDVI are calculated using Ideal Body Surface Area (IBSA). IBW and IBSA are based on the patient category, gender and height that you have entered for the patient.

Using the C.O. Procedure Window

The procedure window displays up to six trials (measurement curves) with the trial number and the C.O. value under the thermodilution curve. When you open the window, a line of pop-up keys automatically appears to let you carry out C.O.-related tasks. This example shows the procedure window for the transpulmonary (PiCCO) Method. The window may be configured to look slightly different on your monitor.

To open the procedure window,

- Select **Cardiac Output** in the **Setup C.O.** or **Setup CCO** menu, or
- Select the **Cardiac Output** SmartKey on the Screen, if configured, or
- Press a remote start switch, if you are using one.

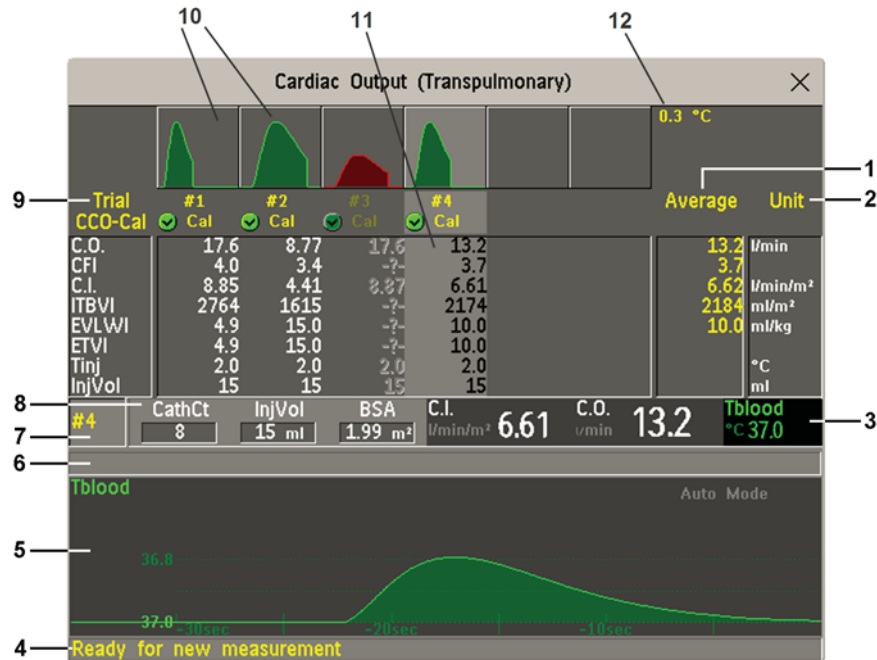

1 **Average** - column of averaged values

2 **Unit** column

3 Continuously measured numeric

4 Prompt message field

5 Thermodilution curve of current trial

6 Curve alert message field

7 Current trial number

8 Setup information

9 **Trial** numbers for the trial curves

10 Trial curves

11 Results table of current trial

12 Trial curve scale

- To change the measurement parameters shown in the results table of the procedure window, select the **Table Contents** pop-up key and choose from the list of available parameters.
- To view the currently-used temperature unit, see the "grayed-out" setting **Temperature Unit** in the **Setup C.O.** menu. This setting can only be changed in Configuration Mode.
- The Cardiac Output screen element may be configured to display permanently on a specially designed Screen. Selecting the screen element opens the cardiac output pop-up keys.

Accessing the Setup C.O. and Setup CCO Menus

C.O. settings can be changed in the **Setup C.O.** menu. To access this menu, select any of the discontinuous C.O. numerics (for example, C.O., C.I.) on the screen.

CCO/CCI settings can be changed in the **Setup CCO** menu. To access this menu, select any of the continuously measured hemodynamic numerics (CCO, CCI.) on the screen.

Entering the HemoCalc Window

From the procedure window, select the pop-up key **Hemo Calc** to open the **Hemo Calculations** window.

Measuring C. O. Using the PiCCO Method

The PiCCO method combines transpulmonary thermodilution and pulse contour analysis on the blood pressure waveform. A fluid with a known volume and temperature is injected into the right atrium through a CVP catheter. The injectate bolus mixes with the blood in the heart and the change in blood temperature is measured with a thermistor at the distal end of an arterial catheter placed in one of the bigger systemic arteries, for example, the femoral or the axillary artery.

The PiCCO Method requires a pressure measurement made using either the M1006B Pressure module, or an M3001A/M3001AL/M3002A/867030/867036 Multi-Measurement Module or a Measurement Extension 867041, 867040, 867039, M3015A/B, M3014A, or M3012A. (A pressure from an external device may not be used.) You will also need a conventional central venous (CVP) line and an arterial catheter from PULSION Medical Systems. You must use the approved catheters and puncture locations.

Measuring Continuous Cardiac Output

Every time C.O. is measured with the PiCCO method, the monitor uses this C.O. value and the result of the pulse contour analysis to calculate a patient-specific calibration factor. The monitor uses this value to compute CCO and the other continuous hemodynamic parameters. CCO values are calculated on a beat-to-beat basis and then averaged over a 12-second time frame. The calculated values are displayed as numerics on the monitor screen.

Measuring Systemic Vascular Resistance

The monitor uses CCO, an arterial pressure, and CVP to calculate a continuous SVR value. If a continuously measured CVP value is not available, the monitor uses a preset, static CVP value to calculate the SVR (you will see the INOP message **SVR Set CVP Used**). If the BSA is available, the monitor uses the CCI to calculate the SVRI. A CCO or CCI from an external device can also be used for the SVR/SVRI calculation.

SVR/SVRI settings can be changed in the corresponding setup menu. To enter the menu, select **Main Setup** then **Measurements** followed by **SVR** or **SVRI**.

To display a **SVR/SVRI** numeric on the Screen, select any numeric, then select **Change Numeric** and select **SVR** or **SVRI** from the list of available numerics.

Measuring Pulse Pressure Variation

The Pulse Pressure Variation functionality in the X2 Multi-Measurement Module is not available in the USA and other territories relying on FDA market clearance.

Pulse Pressure Variation can be calculated in two different ways on this monitor - in conjunction with CCO or directly from the pressure measurement. Refer to the Invasive Pressure chapter for information on PPV from pressure. Only one PPV can be active at a time.

Pulse Pressure Variation (PPV) is calculated from beat-to-beat arterial pressure values. Pulse pressure is the difference between the systolic and the diastolic pressure values for a single beat. Pulse pressure variation is defined as the maximal pressure less the minimum pressure divided by the average of these two pressures.

WARNING

- The monitor calculates PPV from beat-to-beat values of the arterial pressure selected for CCO. The circumstances under which the calculation of a PPV value is clinically meaningful, appropriate and reliable must be determined by a physician.
- The clinical value of the derived PPV information must be determined by a physician. According to recent scientific literature, the clinical relevance of PPV information is restricted to sedated patients receiving controlled mechanical ventilation and mainly free from cardiac arrhythmia.
- PPV calculation may lead to inaccurate values in the following situations:
 - at respiration rates below 8 rpm
 - during ventilation with tidal volumes lower than 8 ml/kg
 - for patients with acute right ventricular dysfunction ("cor pulmonale").
- The PPV measurement has been validated only for adult patients

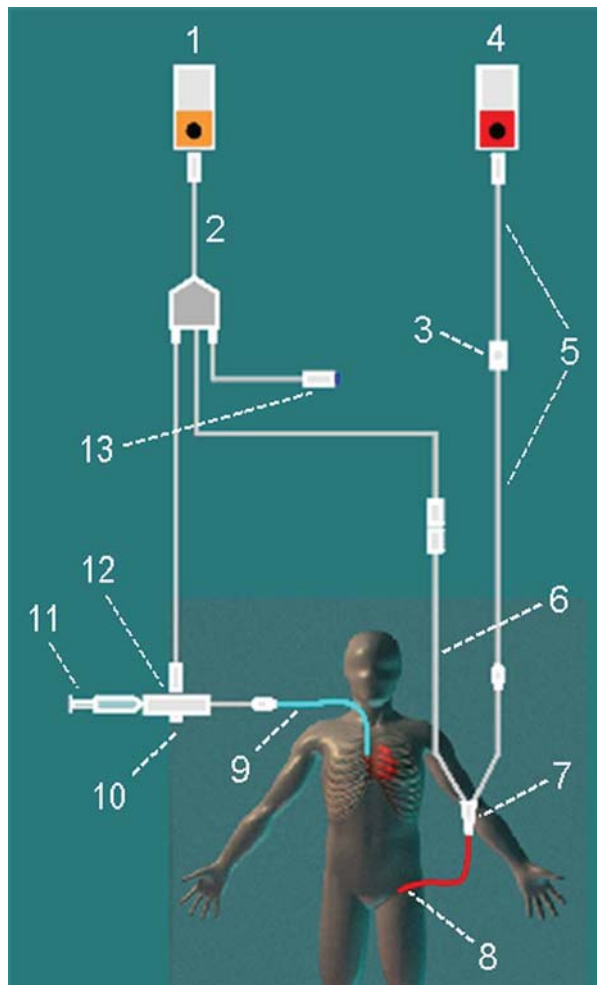
Setting Up the PiCCO C.O. Measurement

- 1 C.O. Measurement
- 2 C.O. Interface Cable
- 3 PULSION Pressure Transducer
- 4 Pressure Measurement
- 5 Pressure Adapter Cable
- 6 Thermistor Connection Cable
- 7 Thermistor Connection
- 8 PULSION Arterial Catheter
- 9 CVP Line
- 10 Injectate Temperature Probe Housing
- 11 Injectate Syringe
- 12 Injectate Temperature Probe
- 13 Remote Switch

14 Monitoring Cardiac Output

- 1 Set up the arterial line using the arterial catheter (transpulmonary catheter) and the transducer kit from PULSION Medical Systems. It must be placed in one of the bigger systemic arteries, for example, the femoral or the axillary artery. You must use the approved catheters and puncture locations.
- 2 Set up the central venous line.
- 3 Connect the injectate temperature probe housing to the venous line.
- 4 Plug the C.O. interface cable into the C.O. measurement extension or module and connect the following devices to the C.O. interface cable:
 - Injectate temperature probe
 - Thermistor connector
 - Remote start switch (if used).

Follow your hospital standards to avoid unintentional extraction of the C.O. catheter. Secure the cable using the mounting clip shipped with each C.O. interface cable. You may also find it helpful to loop the C.O. interface cable, tape the loop, and attach it to the undersheet of the patient's bed using a safety pin.

- 5 If you are measuring CCO, set up the pressure measurement now. The CCO measurement requires a minimally dampened invasive pressure setup. You must ensure that there are no air bubbles in the pressure line or dome and use only specified accessories.
- 6 Check that the correct measurement method is selected.
If a catheter is already connected to the Cardiac Output Interface Cable, the monitor automatically recognizes the method used. If not, in the **Setup C.O.** menu, select **Method** and then select **Transpulmny**.
- 7 Check that you are using the correct probe - the M1646. This is the only probe supported for use; it can be used with room temperature injectate or with cold injectate.
- 8 Check that the correct arterial catheter constant is selected.
If the catheter is recognized by the monitor, the catheter constant is automatically displayed and cannot be changed manually. If it is not recognized, in the procedure window, select **CathCt** and use the pop-up keypad to enter the correct value. The catheter constant is usually written either on the catheter or on the catheter packaging.
- 9 Make sure that the injectate volume setting matches the injectate volume you will use. To change the volume, in the procedure window, select **InjVol** and select the correct injectate volume from the pop-up list.
If there is a problem with the volume or temperature you have chosen, the monitor will issue a curve alert message to inform you of this.
- 10 If you are measuring CCO or CCI, check that the correct pressure source is selected in the **Setup CCO** menu. The pressure label under **CCO from** must match the pressure measured with the arterial catheter. To change the pressure source, select **CCO from** to call up a list of available pressure labels and select the correct label.
- 11 If you are measuring CCO or CCI, verify that the correct alarm source is selected in the menu item **Alarms from**. To change the alarm source, select **Alarms from** and choose either **CCO** or **CCI**.
- 12 Check whether values have been entered for patient category, gender, weight and height by selecting **BSA** in the procedure window. If not, enter the values before making a measurement, as they are used to calculate Ideal Body Weight (IBW) and Ideal Body Surface Area (IBSA). IBW and IBSA are required to calculate Extravascular Lung Water Index and Preload Indexes.

Performing PiCCO C.O. Measurements

Always wait for the monitor to indicate readiness for the next step before proceeding.

If you are measuring CCO, all measurements should be conducted within 15 minutes. Older measurements "expire" for CCO calibration.

- 1 Enter the procedure window.
- 2 When you see the message **Ready for new measurement**, start the measurement by selecting the pop-up key **Start C.O.** or pressing the remote start switch. If the measuring mode is set to **Auto** the **Start C.O.** key will also enable the automatic start of consecutive measurements.
- 3 When you hear the ready tone and see the message **Stable baseline, inject now!**, inject the solution into the CVP catheter.
At the end of the measurement the thermodilution curve, cardiac output, index values, ITBV and EVLW values and any curve alerts are displayed and a message will appear **Wait before starting new measurement** or in **Auto** mode **Prepare for next injection or press Stop**.
- 4 When you see the **Stable baseline, inject now!** message, repeat the procedure until you have completed the measurements you want to perform. You can perform a maximum of 6 measurements before editing. If you perform more than 6 measurements without rejecting any, the oldest will automatically be deleted when a 7th curve is stored.

Editing PiCCO C.O. Measurements

It is important to identify and reject erroneous trials, as the monitor uses all the measurement trial values you do not reject to calculate the averaged cardiac output.

- 1 Review the trials. Irregular trials or trials marked with a "?" should be reviewed carefully. Consider the similarity of the values and the shape of the C.O. curve. A normal C.O. curve has one smooth peak and returns to the temperature baseline level after the peak.
- 2 Reject unsatisfactory trials: use the **Select Trial** pop-up key to move between trials, then select the **Accept Reject** pop-up key to accept or reject trials. If you are using a touch screen you can accept or reject trials directly by tipping on the trial curve. Discard conspicuously different values. The background of rejected trials is red and the background of accepted trials is green. The monitor recalculates the average values after you reject or accept trials.
If all values are different from each other, there may be true hemodynamic instability caused, for example, by severe cardiac arrhythmia.

Saving and Calibrating PiCCO C.O. Measurements

When you have finished editing the trials, you must save the results. This closes the measurement series, sends the average C.O. numeric to be displayed on the main screen, and stores the averaged values in the trends and calculations databases.

Before the monitor can calculate CCO, you must calibrate the measurement. You should also calibrate CCO every eight hours, or if the hemodynamic condition of the patient changes consistently in the same direction over 15 minutes, or if there are large or sudden changes in the patient's condition.

The monitor only uses C.O. measurements from within the last 15 minutes for calibrating CCO.

To save and calibrate,

- In the procedure window, select the pop-up key **SaveC.O. &Cal CCO** to use the averaged C.O. value to calibrate Continuous Cardiac Output (CCO).

Your monitor may be configured to have two separate pop-up keys, **Save C.O.** and **Cal CCO**, instead of the combined **SaveC.O. &Cal CCO**.

WARNING

CCO calibration is patient-specific. When the C.O. measurement extension or module is plugged in after the patient has changed, make sure that the correct CCO calibration is used. When in doubt perform a new CCO calibration first.

CCO Calibration Status Indicators

Each measurement trial is tagged with a calibration status indicator next to its trial number. Reflecting the quality of the pressure signal during the thermodilution measurement, this tag indicates each trial's validity to be used in a CCO calibration.

For a trial to be eligible for calibration, the pressure signal must be continuously available and undisturbed starting 30 seconds before the first C.O. measurement of the series. Do not zero the pressure measurement, change the pressure label, or disturb the pressure signal in any other way during this time.

Cal	A pressure signal for CCO was available during the measurement (valid for calibration)
?Cal	A disturbed pressure signal for CCO was available during the measurement (valid for calibration)
N/A	No adequate pressure signal for CCO was available during the measurement (no valid calibration data)
Exp	This trial is more than 15 minutes older than the most recent trial and has expired for CCO calibration (no valid calibration data)

Measuring C.O. Using the Right Heart Thermodilution Method

In the right heart thermodilution method, a fluid of known volume and temperature is injected into the right atrium through the proximal port of a pulmonary artery (PA) (Swan-Ganz) catheter. The injectate bolus mixes with the blood in the right ventricle and the change in blood temperature is measured with a thermistor at the distal end of the catheter in the pulmonary artery.

Setting up RH C.O. Measurements

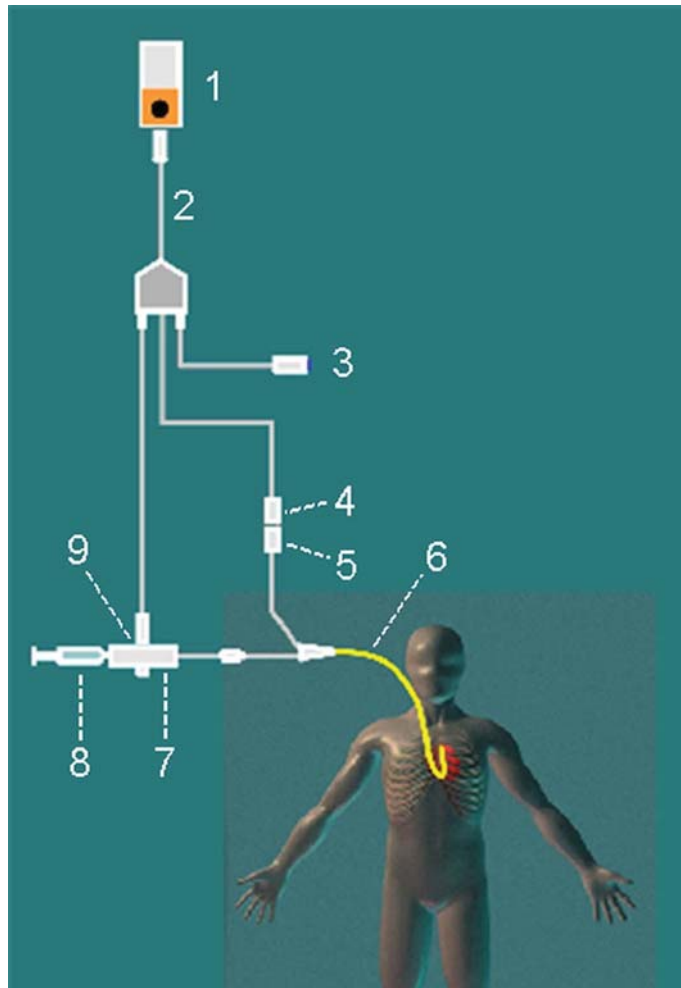

- 1 C.O. Measurement
- 2 C.O. Interface Cable
- 3 Remote Start Switch
- 4 Thermistor Connector
- 5 Thermistor Connection Cable
- 6 PA Catheter
- 7 Injectate Temperature Probe Housing
- 8 Injectate Syringe
- 9 Injectate Temperature Probe

- 1 Set up the PA line using a PA catheter.
- 2 Attach the injectate temperature probe housing to the PA line.
- 3 Plug the C.O. interface cable into the C.O. measurement extension or module and connect the following devices into the C.O. interface cable:
 - injectate temperature probe
 - remote start switch (if used).

Follow your hospital standards to avoid unintentional extraction of the C.O. catheter. Secure the cable using the mounting clip shipped with each C.O. interface cable. You may also find it helpful to loop the C.O. interface cable, tape the loop, and attach it to the undersheet of the patient's bed using a safety pin.

- 4 Plug the thermistor connection cable of the PA catheter into the thermistor connector.
- 5 Connect the injectate temperature probe to the injectate temperature probe housing.
- 6 Check that the correct measurement method is selected.
If a catheter is already connected to the Cardiac Output Interface Cable, the monitor automatically recognizes the method used. If not, in the **Setup C.O.** menu, select **Method** and then select **Right Heart**.

Ice-Bath Setup for RH Thermodilution C.O. Measurements

If you are using the flow-through method illustrated above, the injectate temperature is measured at the time of injection by the temperature probe in the injectate temperature probe housing.

If you are using the ice-bath setup, the injectate temperature probe and the injectate are both placed in an ice-bath and the probe measures the temperature of the contents of the ice bucket.

Setting the Computation Constant

Check that the correct **Computation Constant** is entered in the procedure window. This can be found in the documentation supplied with the catheter and is based on the injectate volume, injectate temperature and catheter type. To change the value, in the procedure window, select **Computation Constant** and use the pop-up keypad to enter the correct value.

Performing RH C.O. Measurements

- 1 Enter the procedure window.
- 2 When you see the message **Ready for new measurement**, select the pop-up key **Start C.O.**. If the measuring mode is set to **Auto** the **Start C.O.** key will also enable the automatic start of consecutive measurements.
- 3 When you hear a ready tone and see the message **Inject now!**, inject the solution into the right atrial port of the Swan-Ganz catheter. The optimal injection rate is 2.5 ml/second.
At the end of the measurement the thermodilution curve, cardiac output, index values and curve alerts (if necessary) are displayed and a message will appear **Wait before starting new measurement** or in **Auto** mode **Prepare for next injection or press Stop**.
- 4 When you see the **Inject now!** message, repeat the procedure until you have completed the measurements you want to perform. You can perform a maximum of six measurements before editing. If you perform more than six measurements without rejecting any, the oldest will automatically be deleted when a seventh curve is stored.

Editing and Saving RH C.O. Measurements

It is important to identify and reject erroneous measurements (called "trials"), as the monitor uses all the measurement trial values you do not reject to calculate the averaged cardiac output.

- 1 Review the trials. Irregular trials or trials marked with a "?" should be reviewed carefully. Consider the similarity of the values and the shape of the C.O. curve. A normal C.O. curve has one smooth peak and returns to the temperature baseline level after the peak.
- 2 Reject unsatisfactory trials: use the **Select Trial** pop-up key to move between trials, then select the **Accept Reject** pop-up key to accept or reject trials. If you are using a touch screen you can accept or reject trials directly by tipping on the trial curve. Discard conspicuously different values. The background of rejected trials is red and the background of accepted trials is green. The monitor recalculates the average values after you reject or accept trials.
If all values are different from each other, there may be true hemodynamic instability caused, for example, by severe cardiac arrhythmia.
- 3 Save average C.O. values. To close a measurement series, you must save the average values by selecting the pop-up key **Save C.O.**. This sends the average C.O. numeric to be displayed on the main screen, and stores the averaged values in the trends and calculations databases.

Documenting C.O. Measurements

You can document C.O. measurements on the default printer or recorder.

- 1 In the procedure window, select the pop-up key **Print/ Record**.
- 2 From the pop-up list, choose:
 - **Print Results** to print the contents of the procedure window
 - **Record Results** to record the contents of the procedure window
 - **Record Trial** to send an individual trial curve to the recorder.

C.O. Injectate Guidelines

The greater the injectate volume and the colder the temperature, the more accurate the measurement. Reduced injectate volume or higher injectate temperature may reduce the specified accuracy.

For adult patients, to ensure the greatest measurement accuracy, use a cold injectate ($< 8^{\circ}\text{C}$) of 10 ml volume, if not contra-indicated by the patient's condition. Your choice of injectate volume should be based on the injectate temperature and the patient's cardiac output.

Guidelines for Right Heart Thermodilution C.O. Injectate

If you are using the right heart thermodilution method, the use of injectate with a temperature less than 8°C lower than the blood temperature may cause incorrect values for the thermodilution.

Guidelines for PiCCO C.O Injectate

If you are using the PiCCO method, the use of injectate with a temperature that is not at least 12°C lower than the blood temperature may cause incorrect values for the thermodilution and CCO calibration.

Injectate Volume, Patient Weight and ETVI Values (PiCCO Only)

When deciding on an injectate volume and temperature, you must consider your patient's Ideal Body Weight (IBW) and extra-vascular thermal volume index (ETVI). IBW is based on the patient category, gender and height that you have entered for the patient. The calculated IBW is displayed in the window that opens when you select the **InjVol** field.

High ETVI

The dilution of injectate is influenced by extravascular tissue and fluid. The accuracy of the PiCCO method may be reduced in patients with high extra-vascular thermal volume index (ETVI) values. Use the table below as a guide in selecting the correct injectate temperature. As shown in the table, if your patient has an $\text{ETVI} > 10$, you must use cold injectate.

Weight

Use the table below as a guide in choosing an injectate volume appropriate for the patient weight.

IBW	Cold Injectate		Room Temperature Injectate	
	ETVI < 10	ETVI ≥ 10	ETVI < 10	ETVI ≥ 10
< 3 kg	2 ml	2 ml	3 ml	Use cold injectate
< 10 kg	2 ml	3 ml	3 ml	
< 25 kg	3 ml	5 ml	5 ml	
< 50 kg	5 ml	10 ml	10 ml	
< 100 kg	10 ml	15 ml	15 ml	
≥ 100 kg	15 ml	20 ml	20 ml	

C.O./CCO Curve Alert Messages

After each measurement trial, the monitor analyzes the thermodilution curve. If the curve appears abnormal, a curve alert message appears in the procedure window. A question mark symbol ("?") may appear next to the cardiac output numeric if any of these messages appear. The curve alert messages are not error messages and do not necessarily mean that the measured values are invalid.

C.O./CCO Curve Alert Messages	Possible Causes
Tinj off scale	The Tinjectate is out of the range -1°C and 30°C. Cool down or heat up the injectate or change the injectate solution and repeat the measurement.
Noisy baseline	A blood temperature baseline drift that could not be compensated was detected during the C.O. measurement. Possible causes are: <ul style="list-style-type: none"> - Interference may be caused by a ventilator. - Interference may be caused by an infusion pump: infusions of significant volume through the central line should be paused at least 30 seconds before the first thermodilution measurement in a series and should not recommence until the measurement series is completed. - Do not administer injections through the central line during a measurement series. - Electrical devices in the vicinity can cause interference: check for infusion pumps connected to the central catheter, cables parallel to the thermodilution cable, electrocautery. Make sure all devices are properly grounded. - Wait until measurement results are displayed before moving the patient or catheter. - Close the stopcock to the injectate syringe after the injection. - Do not rinse the catheter during measurement, to avoid temperature fluctuations.
Temperature baseline drift	May occur if patient is recovering from open heart surgery, or if patient was cooled down for surgery and is in the process of regaining normal body temperature when the measurement is made.

C.O./CCO Curve Alert Messages	Possible Causes
Small signal, more indicator required	The peak of the transpulmonary thermodilution curve was below 0.1°C. Increase injectate volume and/or lower injectate temperature.
Injectate temperature too high	The difference between the blood and injectate temperatures is too small. The calculated value for C.O. may not be accurate.
High ETVI, use cold injectate or greater inj. volume	The ETVI value is too high. The accuracy of the transpulmonary thermodilution measurement may be reduced. Increase injectate volume and/or lower injectate temperature following the guidelines given in the section “Guidelines for PiCCO C.O Injectate” on page 269.
Disturbed injection	The injection should be performed quickly and with a steady pressure. Shaking, unsteady pressure, or injections that take longer than six seconds may cause this message to appear; you should bear this in mind if you are using a large injectate volume (> 10 ml).
Check Injectate Temperature Probe Type	The recorded T_{inj} signal is uncharacteristic for the M1646 injectate temperature probe. An incorrect probe type may have been used.
Unsteady baseline	There is a noisy baseline, and thermal baseline drift.
Multiple peaks	Caused by faulty injection technique.
Abnormal decay time	May be caused by low cardiac output. Calculated value for C.O. may not be accurate.
Very long curve	The decay time of the curve is longer than 15 seconds.
Very short curve	Decay time of the curve is less than 0.5 seconds. If there is a noisy baseline, part of the baseline may have been mistaken for a thermodilution curve. Calculated value for C.O. may not be accurate.
Irregular curve	Any combination of curve alert messages.
Delayed injection	Injection is given more than 15 seconds after Start C.O. is selected. Calculated value for C.O. may not be accurate.

If you have followed all of these guidelines, your measurement values should be valid, even if you still see a curve alert message. Ensure that at least three subsequent measurements within the current series do not differ by more than 15%. If the difference exceeds 15%, use your clinical judgment to determine the appropriate intervention.

C.O./CCO Prompt Messages

Prompt messages appear in the procedure window if a C.O. measurement trial must be terminated.

C.O./CCO Prompt Messages	Possible Causes
Curve below baseline, measurement terminated	May be caused by thermal baseline drift. No C.O. value calculated.
Excessive curve height, measurement terminated	The curve exceeds the upper limit. This may be caused by an injectate that was too cold. No C.O. value calculated.

C.O./CCO Prompt Messages	Possible Causes
Unstable baseline, injection not recommended!	The baseline is unstable. Wait until the baseline is stable before injecting. If this does not occur within a reasonable time, injection is possible but the accuracy of the measured values may be reduced.
Excessive baseline drift, don't inject now!	No measurement is possible. Measured values are incorrect.

C.O./CCO Warning Messages

Warning messages contain important information about the C.O. measurement.

C.O./CCO Warning Messages	Possible Causes
Next measurement erases older curve	Six curves are stored, this is the maximum possible. If another measurement is stored, the oldest thermodilution curve will be erased.
Previous C.O. setup data replaced	A C.O. measurement extension or module has been plugged in with different C.O. setup data from the previous data. The new C.O. setup data is read from the new C.O. device, and replaces the current data. The message disappears when the Start C.O. pop-up key is pressed.
Verify C.O. setup data	A new transpulmonary thermodilution catheter has been connected to the C.O. Interface Cable.
Check arterial pressure, CCO cal currently not possible	Poor or invalid pressure signal, for example if pressure was not zeroed.
Verify the Computation Constant	A new catheter has been plugged in, or the computation constant has been changed and Start C.O. has not been selected.
Previous Comp. Constant replaced	A new C.O. measurement extension or module with a different computation constant from the current one has been connected. The new computation constant is read from the new C.O. device, and replaces the current one. The message disappears when Start C.O. is selected.

C.O./CCO Safety Information

WARNING

Catheter constant - Make sure that the arterial catheter constant for the measurement is appropriate to the catheter used.

Computation Constant - Make sure that the computation constant for the measurement is appropriate to the injectate volume, injectate temperature and catheter type used.

IABP - Do not perform transpulmonary thermodilution measurements on patients undergoing IABP treatment.

CCO accuracy - Accuracy of the CCO measurement and all the derived values may be influenced by patients with valve diseases or artificial valves.

C.O. and MRI - Do not use the Cardiac Output Interface Cable in Magnetic Resonance Imaging (MRI) Applications.

Aortic graft patients - Do not use an arterial catheter in the arteria femoralis when it is contra indicated, for example, with patients who have an aortic graft.

CAUTION

During the cardiac output measurement procedure the blood temperature alarms are inactive. This is indicated by a crossed-out alarm symbol next to the temperature numeric. Making alarms inactive during this procedure prevents false alarms. The alarms are automatically reactivated when you have completed the measurement procedure.

Monitoring Carbon Dioxide

WARNING

Measurements from **any** Measurement Extension connected to an X2, or from a **previous generation** Measurement Extension connected to an X3, are not available when the X2/X3 is running on its own battery power. They are only available when the X2/X3 is powered by external power: when connected to a host monitor, IntelliVue Dock or to the Battery Extension (865297).

Only one CO₂ measurement at a time is supported.

Use the CO₂ measurement to monitor the patient's respiratory status and to control patient ventilation.

There are two methods for measuring carbon dioxide in the patient's airway:

- Mainstream measurement uses a CO₂ sensor attached to an airway adapter directly inserted into the patient's breathing system. This method is available using
 - the 867040 or M3014A Capnography Extension, or
 - the X2/X3 or the MMX Multi-Measurement Module with the optional CO₂ measurement (Respironics CAPNOSTAT technology).
- Sidestream measurement takes a sample of the respiratory gas with a constant sample flow from the patient's airway and analyzes it with a remote CO₂ sensor built into the measurement system. Philips offers the sidestream CO₂ measurement in
 - the 867040 or M3014A Capnography Extension, or
 - the X2/X3 or MMX Multi-Measurement Module with the optional CO₂ measurement (Respironics LoFlo technology).
- The Microstream method of sidestream CO₂ measurement is available using the 867041 or M3015A/B Microstream CO₂ Extension (Medtronic Microstream technology).

NOTE

See your Gas Module Instructions for Use, if you are using a Gas Module to monitor CO₂.

WARNING

Correlation: The etCO_2 readings do not always correlate closely with paCO_2 , especially in neonatal patients and patients with pulmonary disease, pulmonary embolism or inappropriate ventilation.

Pharmaceuticals in aerosols: Do not measure CO_2 in the presence of pharmaceuticals in aerosols.

Explosion Hazard: Do not use in the presence of flammable anesthetics or gases, such as a flammable anesthetic mixture with air, oxygen or nitrous oxide. Use of the devices in such an environment may present an explosion hazard.

Failure of operation: if the measurement or a sensor fails to respond as described, do not use it until the situation has been corrected by qualified personnel.

Low etCO_2 values: Leakages in the breathing system or sampling system may cause the displayed etCO_2 values to be significantly too low. Always connect all components securely and check for leaks according to standard clinical procedures. Displacement of the nasal or combined nasal oral cannulas can cause lower than actual etCO_2 readings. Even with combined nasal oral cannulas, the etCO_2 readings may be slightly lower than actual in patients breathing through the mouth only.

Measurement Principles

For both mainstream and sidestream measurements, the measurement principle is infrared transmission, where the intensity of infrared light passing the respiratory gas is measured with a photo detector. As some of the infrared light is absorbed by the CO_2 molecules, the amount of light passing the gas probe depends on the concentration of the measured CO_2 .

When using a wet ventilator circuit, monitor mainstream CO_2 if available, in preference to sidestream CO_2 .

The partial pressure is calculated from the gas concentration by multiplying the concentration value with the ambient pressure.

The measurement provides:

- a CO_2 waveform.
- an end tidal CO_2 (etCO_2) value: the CO_2 value measured at the end of the expiration phase.
- an inspired minimum CO_2 (imCO_2): the smallest value measured during inspiration.
- an airway respiration rate (awRR): the number of breaths per minute, calculated from the CO_2 waveform.

Medtronic Microstream Technology only

Depending on the **Max Hold** setting configured for your monitor, the etCO_2 numeric shows either the highest CO_2 value measured within the configured time period (**Max Hold** set to **10 sec** or **20 sec**) or the etCO_2 numeric shows breath-to-breath value (**Max Hold** set to **Off**).

The Microstream method also provides an **Integrated Pulmonary Index (IPI)** numeric, which is an indication of the patient's overall ventilatory status based on four measurement parameters: etCO_2 , awRR , pulse rate and SpO_2 . IPI can thus provide an early indication of a change in ventilatory status which may not be shown by the current value of any of these four parameters individually. The IPI is designed to provide additional information regarding patient status, possibly before etCO_2 , awRR , SpO_2 , or pulse rate values reach levels of clinical concern.

The IPI is available for all three groups of pediatric patients (1-3 years, 3-6 years, and 6-12 years), and for adult patients. It is displayed as a single value between 1 and 10.

For the IPI calculation, the SpO₂ and pulse values from the Multi-Measurement Module are used. Availability of these values does not depend on the labels used or the SpO₂ technology in the Multi-Measurement Module. SpO₂ and pulse values from other sources (plug-in SpO₂ module, external devices connected via IntelliBridge) cannot be used for the IPI calculation.

Measuring CO₂ using 867040, M3014A, MMX or X2/X3

The 867040 and M3014A Capnography Extensions or the X2/X3 or MMX Multi-Measurement Module with the CO₂ option measure partial pressure of carbon dioxide in a patient's expired gas using the mainstream method or the sidestream method.

The mainstream CO₂ measurement can be used, with appropriate accessories, with intubated adult, pediatric and neonatal patients. The sidestream CO₂ measurement can be used, with appropriate accessories, with intubated and non-intubated adult, pediatric, infant and neonatal patients. With intubated patients, a sample of the respiratory gas is drawn from the patient's breathing circuit through an airway adapter and a gas sampling tube. With non-intubated patients, the gas sample is drawn through a nasal or oral-nasal cannula.

WARNING

Altitude Setting: The monitor is not equipped with automatic barometric pressure compensation. Before the CO₂ measurement is used for the first time, the altitude must be set to the correct value. An incorrect altitude setting will result in incorrect CO₂ readings. The CO₂ readings will typically deviate 5% for every 1000 m difference.

CAUTION

Use the CO₂ measurement with Philips approved accessories only. Refer to the instructions for use provided with the accessory.

Preparing to Measure Mainstream CO₂

You must perform a zero as described in this procedure each time you use a new airway adapter.

- 1 Attach the sensor connector to the CO₂ connector on the Measurement Extension, or on the MMX, X2 or X3 (when the optional CO₂ measurement is integrated).
- 2 Wait 2 minutes, allowing the sensor to reach its operating temperature and a stable thermal condition.
- 3 Choose the appropriate airway adapter and connect it to the sensor head. The airway adapter clicks into place when seated correctly.

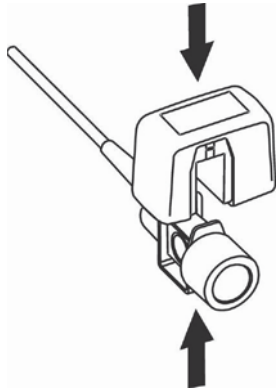

- 4 Zero the sensor:
 - Expose the sensor to room air and keep it away from all sources of CO₂ including the ventilator, the patient's breath and your own.
 - In the setup menu for the CO₂, select **Start Zero Cal.**
 - When you see the message **CO₂ calibration done at <Date and Time>** on the screen, the zero calibration is finished and you can begin monitoring.
- 5 Install the airway adapter at the proximal end of the circuit between the elbow and the ventilator Y-section.

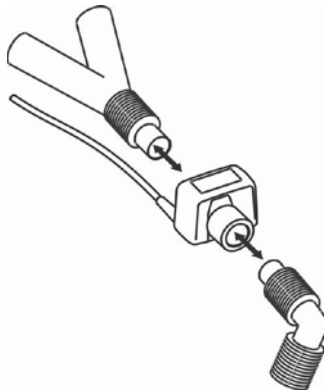

WARNING

To prevent stress on the endotracheal tube, support the sensor and airway adapter.

Position sensor cables and tubing carefully to avoid entanglement or potential strangulation. Do not apply excessive tension to any cable.

Replace the airway adapter, if excessive moisture or secretions are observed in the tubing or if the CO₂ waveform changes unexpectedly without a change in patient status.

To avoid infection, use only sterilized, disinfected or disposable airway adapters.

Inspect the airway adapters prior to use. Do not use if airway adapter appears to have been damaged or broken. Observe airway adapter color coding for patient population.

Preparing to Measure Sidestream CO₂

- 1 Plug the sensor cable into the monitor's CO₂ input connector. Allow the sensor two minutes warm up time

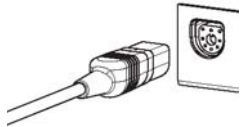

- 2 Connect the cannula, airway adapter, or sample line as appropriate, to the sensor. It will click into place when seated correctly.

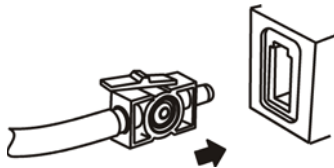

- 3 To zero the sensor:
 - expose the sensor to room air and keep it away from all sources of CO₂ including the ventilator, the patient's breath and your own.
 - in the setup menu for the CO₂, select **Start Zero Cal**.
 - when you see the message **CO₂ calibration done at <Date and Time>** on the screen, the zero calibration is finished and you can begin monitoring.
- 4 *For intubated patients requiring an airway adapter:* Install the airway adapter at the proximal end of the circuit between the elbow and the ventilator Y-section.

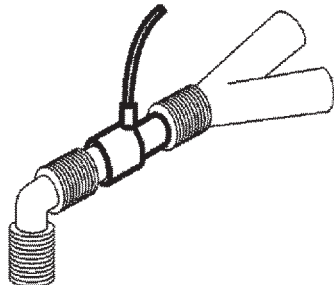

For intubated patients with an integrated airway adapter in the breathing circuit: Connect the male luer connector on the straight sample line to the female port on the airway adapter.

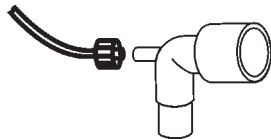

For non-intubated patients: Place the nasal cannula onto the patient.

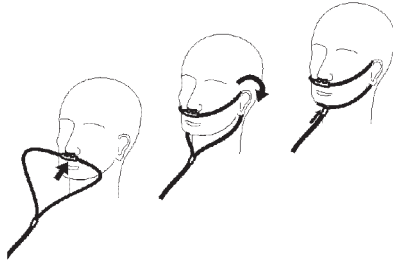

For patients prone to mouth breathing use an oral-nasal cannula.

For nasal or oral-nasal cannulas with oxygen delivery, place the cannula on the patient as shown then attach the oxygen supply tubing to the oxygen delivery system and set the prescribed oxygen flow.

WARNING

Always connect the airway adapter to the sensor before inserting the airway adapter into the breathing circuit. In reverse, always remove the airway adapter from the breathing circuit before removing the sensor.

Make sure that you do not accidentally connect the luer connector of the gas sample line to an infusion link or any other links in the patient vicinity.

CAUTION

Always disconnect the cannula, airway adapter or sample line from the sensor when not in use.

Using the Sidestream Sensor Holder

The holder delivered with the sensor can be used to clamp the sensor onto an IV pole or a shelf.

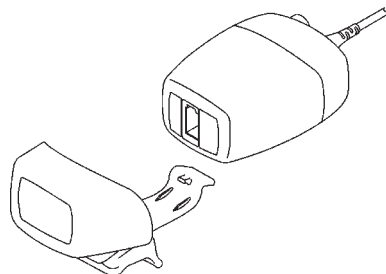

- 1 Push the sensor into the holder until it clicks into position.
- 2 Clamp the holder onto an IV pole, a shelf or another appropriate location.

To remove the sensor from the holder, release the clip and pull the sensor out of the holder.

Removing Exhaust Gases from the System

WARNING

- **Anesthetics:** When using the sidestream CO₂ measurement on patients who are receiving or have recently received anesthetics, connect the outlet to a scavenging system, to avoid exposing medical staff to anesthetics.
- **Patient cross-infection:** Do not return the sampled gas to the breathing system of the patient.
- Make sure that you do not accidentally connect the exhaust tube to an infusion link or any other links in the patient vicinity.
- Ensure that the tubing is positioned to avoid kinking or compression that could cause an occlusion.

Use an exhaust tube to remove the sample gas to a scavenging system. Attach it to the sidestream sensor at the outlet connector.

Measuring Microstream CO₂ using 867041 or M3015A/B

The Microstream CO₂ Extension measures the partial pressure of carbon dioxide in a patient's expired gas using Microstream technology.

The measurement is equipped with an automatic barometric pressure compensation.

WARNING

When using the IPI numeric (available for adult and pediatric patients), always ensure that the patient's date of birth is entered correctly and that the monitor is displaying the current date. These two pieces of information are used to calculate the age of the patient, which affects the algorithm used to provide the IPI numeric.

Preparing to Measure Microstream CO₂

Use appropriate accessories for:

- the patient type (adult, pediatric or neonatal),
- the ventilation situation (including humidification)
- the duration - short term use, (typically OR), or long term use (typically ICU).

All accessories are for single patient use only.

Using Microstream Accessories

The Microstream measurement can be operated with the special Microstream accessories only. Refer to the instructions for use provided with the accessory.

For intubated patients with non-humidified ventilation, you can use a Microstream FilterLine set. For humidified ventilation, use a FilterLine H Set.

For non-intubated patients, the gas sample is taken through a Nasal FilterLine, or a Smart CapnoLine (which is a combined oral-nasal FilterLine). In parallel to the measurement of the CO₂, oxygen (O₂) may be delivered to the patient to support gas exchange. This is done by using an O₂/CO₂ FilterLine, or a Smart CapnoLine O₂ (a combined oral-nasal O₂/CO₂ FilterLine).

Using the FilterLine and Airway Adapter

WARNING

Make sure that you do not accidentally connect the luer connector of the gas sample line to an infusion link or any other links in the patient vicinity.

- 1 Attach the female Luer connector to the CO₂ inlet connector by pushing the socket cover aside and screwing the connector clockwise into the CO₂ inlet until it can no longer be turned.
This will assure that there is no leak of gases at the connection point during measurement and that measurement accuracy is not compromised. Following connection of the CO₂ sampling line, check that CO₂ values appear on the monitor display.
- 2 Check that the FilterLine is not kinked.
- 3 Change the FilterLine if a **CO₂ Occlusion INOP** appears on the monitor or if the readings become extremely erratic.

Disconnect the FilterLine during suctioning and nebulizing therapies or suppress sampling by turning off the pump as described in “[Suppressing Sampling \(not Mainstream CO₂\)](#)” on page 284.

Check the table in the Microstream CO₂ Accessories section of the Accessories chapter for typical usage times for the different Microstream accessories.

CO₂ values for non-intubated patients using Microstream accessories will always tend to be lower than for intubated patients. If values appear extremely low, check whether the patient is breathing through the mouth or whether one nostril is blocked.

Removing Exhaust Gases from the System

WARNING

- **Anesthetics:** When using the Microstream CO₂ measurement on patients who are receiving or have recently received anesthetics, connect the outlet to a scavenging system, or to the anesthesia machine/ventilator, to avoid exposing medical staff to anesthetics.
- **Patient cross-infection:** Do not return the sampled gas to the breathing system of the patient.
- Make sure that you do not accidentally connect the exhaust tube to an infusion link or any other links in the patient vicinity.
- Ensure that the tubing is positioned to avoid kinking or compression that could cause an occlusion.

Use an exhaust tube to remove the sample gas to a scavenging system. Attach it to the Measurement Extension at the outlet connector.

Suppressing Zero Calibration

To prevent an automatic zero calibration from being started in the next five minutes,

- in the **Setup CO₂** menu, select **No Zero for 5min**, or select the **Suppress CO₂ Zero** SmartKey, if configured.

Selecting **No Zero for 5min** or selecting the **Suppress CO₂ Zero** SmartKey again before the timer has timed out resets the timer to five minutes, unless an AutoZero became due during the previous suppression.

Setting up all CO₂ Measurements

These tasks are common to all CO₂ measurements except where otherwise noted.

Adjusting the CO₂ Wave Scale

- 1 In the **CO₂ Wave** menu or the **Setup CO₂** menu, select **Scale**.
- 2 Choose a suitable scale range from the pop-up list.

Setting up CO₂ Corrections

Temperature, water vapor in the patient's breath, barometric pressure, and the proportions of O₂, N₂O and Helium in the mixture all influence CO₂ absorption. If values seem inaccurately high or low, check that the monitor is using the appropriate corrections.

Correction	
Altitude (MMX, X3, 867040 or M3014A only)	Altitude is set during installation. The monitor automatically applies an appropriate correction.
O ₂ (MMX, X3, 867040, M3014A or 867185 only)	In the Setup CO₂ menu, select Oxy. Corr and select a value between 20% and 100%, the default value is 20%.
Humidity (not available for 867185)	At installation, the monitor is configured to automatically apply either Body Temperature Pressure Saturated (BTPS) or Ambient Temperature Pressure Dry (ATPD). To see which, go to the Setup CO₂ menu, and scroll down to look at Hum. Corr or Humidity Corr.
N ₂ O (867041, M3015A/B Microstream or 867185 only)	In the Setup CO₂ menu, select N₂O Corr. and turn on or off. If N ₂ O is present in the ventilation gas mixture, you must turn this on. If the N ₂ O correction is not available in the Setup CO₂ menu, the CO ₂ measurement in your Measurement Extension does not require N ₂ O correction or it is setup with Gas Corr. (see below).
Gas (MMX, X3, 867040 or M3014A only)	In the Setup CO₂ menu, select Gas Corr. and select Helium, N₂O or turn off. If Helium or N ₂ O is present in the ventilation gas mixture, you must make the appropriate selection. If the Gas correction is not available in the Setup CO₂ menu, the CO ₂ measurement in your Measurement Extension does not require N ₂ O or Helium correction or the N ₂ O correction is setup with N₂O Corr. (see above).
Agent (MMX, X3, 867040 or M3014A only)	In the Setup CO₂ menu, select Agt. Corr and select the concentration of the anesthetic agent (between 0.0% and 20.0%). If an anesthetic agent is present in the ventilation gas mixture, you must select the appropriate concentration.

Suppressing Sampling (not Mainstream CO₂)

To temporarily stop sampling, in the **Setup CO₂** menu, select **Pump 15min Off** or use the **CO₂ Pump Off** SmartKey if available.

Selecting **Pump 15min Off** again before fifteen minutes have passed resets the timer to fifteen minutes.

To re-start the pump, in the **Setup CO₂** menu, select **Pump On**.

Changing CO₂ Alarms

This refers to CO₂ specific alarms. See the “Alarms” section for general alarm information.

- 1 In the **Setup CO₂** menu, select **etCO₂ High** or **imCO₂ High** and choose the high alarm limit.
- 2 Select **etCO₂ Low** and choose the low alarm limit.

Changing the Apnea Alarm Delay

This determines the time limit after which the monitor alarms if the patient stops breathing.

- 1 In the **Setup CO₂** menu, select **awRR**.
- 2 In **Setup awRR** menu, select **Apnea Time**.
- 3 Choose the apnea alarm delay time.

WARNING

Safety and effectiveness of the respiration measurement method in the detection of apnea, particularly the apnea of prematurity and apnea of infancy, has not been established.

Prolonged delay: The selected apnea alarm delay may be prolonged by up to 17 seconds, if an apnea occurs during the automatic zero process. This applies to the Microstream (M3015A/B) measurement only.

Deriving Alarms From awRR

- 1 In the **Setup CO₂** menu, select **awRR**.
- 2 In the **Setup awRR** menu, select **Alarms**.
- 3 Choose **On** to derive alarms from the airway respiration signal or **Off** to disable them.

Changing awRR Alarm Limits

- 1 In the **Setup CO₂** menu, select **awRR**.
- 2 Select **High Limit** to set the upper alarm limit.
Select **Low Limit** to set the lower alarm limit.
- 3 Select the appropriate setting.

Changing IPI Alarm Limits

- Medtronic
Microstream
Technology
only**
- 1 In the **Setup CO₂** menu, select **IPI**.
 - 2 Select **Low Limit** to set the low alarm limit.
 - 3 Select a value between 2 and 9.

If you also have monitors with earlier software revisions than J.0, the IPI low alarm will not be generated after a transfer to one of these monitors, or when a monitor/Multi-Measurement Module with the IPI functionality is connected to one of these monitors in companion mode. In this case, do not rely only on the IPI low alarm but leave the individual alarms switched on (etCO₂, awRR, pulse rate and SpO₂) so that these alarms can be generated in such situations.

Understanding the IPI Numeric

- Medtronic
Microstream
Technology
only**
- The index is modeled on normal healthy patients (ASA Physical Status value of 1 according to the ASA Physical Status Classification System). Patients with ASA Physical Status values of 3 or higher are expected to have low IPI values by definition. Therefore, for patients with an ASA Physical Status value of 3 or higher, the index may have no added value.

The value of the Integrated Pulmonary Index given in the IPI numeric is associated with the patient status as follows:

IPI	Patient Status
10	Normal
8-9	Within normal range

IPI	Patient Status
7	Close to normal range; requires attention
5-6	Requires attention and may require intervention
3-4	Requires intervention
1-2	Requires immediate intervention.

NOTE

The interpretation of the patient's IPI score may change in different clinical environments. For example, patients with specific respiratory difficulties (in contrast to normally healthy patients who are being monitored during sedation or pain management) may require a lower IPI Low Alarm threshold to reflect their impaired respiratory capacity.

The IPI is available for all three groups of pediatric patients (1-3 years, 3-6 years, and 6-12 years), and for adult patients.

WARNING

Ensure that the patient category and date of birth are set correctly before monitoring a patient's IPI. An incorrect patient category or date of birth could produce incorrect IPI data.

Measuring Anesthetic and Respiratory Gases

The 866173 IntelliVue G7m Gas Analyzer module hereafter referred to as the “gas analyzer”, measures patients’ anesthetic and respiratory gases. The following table shows the main features for the gas analyzer:

	IntelliVue G7m Gas Analyzer Module
Number of Gases measured	3
Number of Agents measured	5 (2 at a time)
Automatic Agent ID	2 out of 5

The gas analyzer does not allow mixed agent situations with three agents or more. If more than two agents are detected at the same time, the module is not able to measure agent concentration. Agent related measurements are marked as invalid.

The gas analyzer measures the airway respiration rate (awRR) and provides end tidal (et) and inspired (in) values for the following gases:

Respiratory Gases	Anesthetic Agents
Carbon dioxide (CO ₂)	Halothane
Nitrous oxide (N ₂ O)	Isoflurane
Oxygen (O ₂)	Enflurane
	Sevoflurane
	Desflurane

WARNING

If the gas measurement fails, such that the patient can no longer be adequately monitored, use an alternative gas measurement device.

Identifying Gas Analyzer Module Components



- 1 Standby key
- 2 Setup key
- 3 Gas inlet
- 4 Water trap
- 5 Gas outlet
- 6 Standby LED
- 7 RJ45 service port

The standby LED lights up (green) when the gas analyzer is in standby.

Water Trap

The water trap prevents water and other fluids from passing into the gas analyzer and causing contamination and/or internal occlusions. It has a water reservoir in which fluids are collected, two water separation filters, and two shut-off fuses as a backup mechanism for the water separation filters.

The water trap is for multi-patient use. It **must** be replaced after a service life of four weeks at the latest, during this time it can be emptied and reused as often as required. Regularly check the level of fluid in the water trap and empty as required.

WARNING

Risk of gas measurement failure and device failure: After an extended period of use, the hydrophobic membrane in the water trap can become permeable, and water and bacteria can enter the measuring system. Contamination negatively affects the gas measurement and may lead to gas measurement failure.

Risk of inaccurate gas measurement values and gas measurement failure: To avoid influence on the gas measurement and prevent damage to the water trap and measuring system do not spray the O-rings in the water trap housing with silicone spray.

Risk of distorted measurement results: Do not use the water trap with medication nebulizers. Aerosols may damage the membrane and the measuring system. Avoid the use of aerosols in the breathing system.

CAUTION

Never leave the gas analyzer running without the water trap attached. Sucked in dust or cleaning agents may distort measurement results, or irreparably damage the instrument.

The water trap must always be in a vertical position. The module itself can be vertical - in a horizontally mounted Module Rack, or horizontal - in a vertically mounted Module Rack. Always rotate the water trap into the vertical position, as shown below.

The gas analyzer in a horizontally mounted Module Rack.

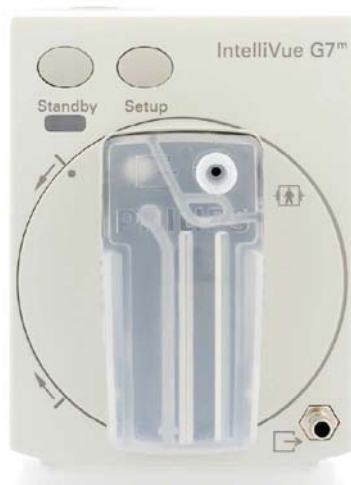

The gas analyzer in a vertically mounted Module Rack.



If the water trap is not vertical (to within $\pm 15^\circ$), an **Align Watertrap** INOP is displayed. Rotate the water trap holder into the vertical position, in the direction of the arrows on the front of the module. When the water trap is vertical, the INOP is cleared and the gas analyzer is operational.

Understanding the Gas Measurement

The IntelliVue G7m gas analyzer module uses a technique called Non-Dispersive Infrared Gas Concentration Measurement (NDIR) to measure the concentration of certain gases.

The gases which can be measured by the gas analyzer absorb infrared (IR) light. Each gas has its own absorption characteristic. The gas is transported into a sample cell, and an optical IR filter selects a specific band of IR light to pass through the gas. For multiple gas measurement, such as in the gas analyzer, there are multiple IR filters. The higher the concentration of gas in a given volume the more IR light is absorbed. This means that higher concentrations of IR absorbing gas cause a lower transmission of IR light. The amount of IR light transmitted after it has been passed through an IR absorbing gas is measured. From the amount of IR light measured, the concentration of gas present can be calculated. This calculation provides the gas measurement value. Oxygen is measured by an additional sensor in the gas analyzer using its paramagnetic properties. The gas is transported into a sample cell. The higher the oxygen concentration, the higher the measured effect. The oxygen concentration can be calculated from the amplitude of the effect.

WARNING

- The presence of organic cleaning solutions or gases containing freon may affect the accuracy of the infrared gas measurement.
- The presence in the gas path of gases, aerosols, etc. other than those specified for the gas analyzer may result in incorrect readings.
- Gas measurement values might be inaccurate at high respiratory rates due to the technical limitations of the gas measurement system. Refer to the measurement specifications.

Making Measurements

The gas analyzer accessories and part numbers are listed in “G7m Gas Analyzer Accessories” on page 463. To avoid condensed water collecting in the gas sample tube, position the gas analyzer at or above the patient level.

- 1 Insert the water trap into the water trap holder. See “Installing the Water Trap” on page 292.
- 2 Connect the gas sample tubing to the gas inlet connector of the water trap.
- 3 Connect the other end of the gas sample tubing to the patient via the airway adapter.
- 4 Connect a gas exhaust return tubing (together with a gas exhaust return filter, if required) to the gas outlet connector.
- 5 Connect the gas exhaust return tubing to the exhaust system.

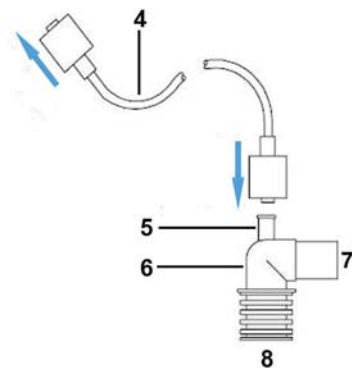

- 1 Gas inlet connector
- 2 Water trap
- 3 Gas outlet connector
- 4 M1658A Gas sample tubing
- 5 Gas sample port
- 6 Airway adapter,
*either 13902A Elbow airway adapter
or M1612A Straight airway adapter*
- 7 Connects to the anesthesia machine
- 8 Connects to the patient

WARNING

Make sure that you do not accidentally connect the gas inlet connector of the gas sample tubing to an infusion link or any other links in the patient vicinity.

Ensure that all of the connections are tight. Any leak in the system can result in erroneous readings due to ambient air mixing with patient gases.

CAUTION

Airway Adapter: Use one of the airway adapters listed in “G7m Gas Analyzer Accessories” on page 463 and position it so that the part connecting to the gas sample tube is pointing upwards. This prevents condensed water from passing into the gas sample tube and causing an occlusion. Philips airway adapters have a built-in port extending from the adapter wall, which reduces the risk of a blockage.

Water trap: To minimize the risk of internal contamination, never leave the gas analyzer running without a water trap attached. If the gas analyzer is run without a water trap, a **Check Watertrap** INOP is displayed after approximately 25 seconds.

Gas Sample Tube: Do not use the gas sample tube if it is kinked, as it may cause an occlusion or leakage.

Room Ventilation: Make sure that the room in which the gas analyzer is used is well-ventilated with fresh air. Gases or fumes that mix with and contaminate the room air may degrade measurement accuracy. Use a gas exhaust return tubing to return gas samples to the breathing circuit or connect a scavenging system to the gas exhaust port and remove the gas sample. A gas exhaust return filter can be used in a "closed-loop" breathing circuit. Note that gas exhaust return filter/tubing may not be available for use in all countries.

Do not use the gas analyzer in a hyperbaric chamber with oxygen enrichment. The ambient air must be free of CO₂ enrichment.

Avoiding Pollution with the Gas Sample

If inhalation anesthetics are used during anesthesia, pollution of the operating room should be prevented by either returning the filtered gas sample to the breathing circuit or by disposing of the gas sample.

Your local regulations or hospital policy may not permit the use of gas return systems.

Returning the Gas Sample

WARNING

There is a risk of patient cross-infection if the sampled gas is returned to the breathing system.

To minimize the risk of patient cross-infection, ensure that single-patient-use accessories are never used on more than one patient.

Use an M1656B gas exhaust return filter and M1655B exhaust return tubing as instructed in the documentation supplied with them, to return the gas sample to the patient's breathing circuit. Make sure the sample gas is routed through the CO₂ absorber before going back to the patient.

Removing the Gas Sample

To remove the gas sample from the breathing circuit, a scavenging system must be connected to the gas exhaust port. Use either:

- a gas exhaust scavenging tube (M1015-40001)
- gas exhaust return tubing (M1655B), without the M1656B exhaust return filter
- a ventilator reservoir, where the suction pressure does not exceed 0.3-0.4 mmHg
- a scavenging interface.

CAUTION

- Make sure to compensate for any possible reduction of tidal volume caused by gas sampling.
- Ensure that the tubing is positioned to avoid kinking or compression that could cause an occlusion.

Understanding the Gas Analyzer Display

The gas analyzer provides waves and numerics for all measured gases for display on the monitor screen. Which waves and numerics are displayed depends on your Screen configuration. The example below shows simulated data from Demonstration Mode.

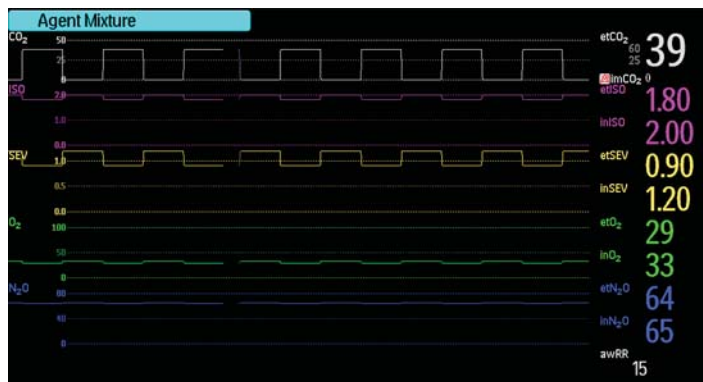

Installing the Water Trap

To install the water trap:

- 1 Remove the new water trap from the packaging.
- 2 Write the current date on the front of the new water trap.

WARNING

When installing the water trap make sure that the three O-rings on the connectors in the water trap holder are in place. If any of the O-rings are missing or damaged, **do not** use the gas analyzer module and contact your service personnel.

- 3 Holding the water trap by the side grips, insert it into the holder until it audibly clicks into place.
- 4 Connect the gas sample tubing to the gas inlet connector on the water trap.



O-rings in the water trap holder



Installing the water trap

Removing the Water Trap

WARNING

If the gas sample tubing remains connected while the water trap is being removed, contaminated liquid may escape from the water trap. Disconnect the gas sample tubing before removing the water trap from the gas analyzer module.

To remove the water trap from the module:

- 1 Place the water trap in the vertical position.
- 2 Disconnect the gas sample tubing from the water trap.
- 3 Squeeze the two side grips (1) together and carefully pull the water trap out of the water trap holder



WARNING

Dispose of the following items as infectious hospital waste:

- water traps which have been taken out of use
- syringes used to empty the water trap
- gas sample tubing
- exhaust return tubing
- exhaust return filters

Follow local waste disposal regulations.

Emptying the Water Trap

Under typical conditions (sample gas temperature 37°C, room temperature 23°C and sample relative humidity 100%) the water trap must be emptied at the latest after 41 hours in use.

WARNING

The water trap is for multi-patient use. It **must** be exchanged every four weeks, during this time it can be emptied and reused as often as required. Regularly check the level of fluid in the water trap and empty as required.

Risk of Infection: Accumulated fluids in the water trap could be contaminated and must be handled and disposed of with care.

Dispose of the syringe used to empty the water trap according to your local regulations and hospital policy. Do not empty the syringe, do not reuse the syringe.

CAUTION

Gas analyzer ports: Do not apply any pressure to the gas analyzer's inlet or outlet ports, for example from a syringe, as this may cause damage to the pneumatic and optical systems.

Never leave the gas analyzer running without the water trap attached. Sucked in dust or cleaning agents may distort measurement results, or irreparably damage the instrument.

- 1 Put the gas analyzer into standby mode.
- 2 Remove the water trap from the module. See [“Removing the Water Trap”](#) on page 293.
- 3 Attach an empty syringe (minimum 20 ml) without a cannula to the black connector on the rear of the water trap (as shown), and carefully extract the fluid from the water trap.



- 4 Remove the fluid-filled syringe from the water trap.
- 5 Clean the water trap.
- 6 Re-install the water trap in the gas analyzer, see [“Installing the Water Trap”](#) on page 292.
- 7 Exit standby mode.

Water Trap Replacement

Replace the water trap:

- When the maximum service life of four weeks has been reached.
- When the water trap is soiled.
- If the self-sealing shut-off fuses in the water trap have turned blue.
- If a **Check Watertrap** or **<Gas Analyzer> Occlusion INOP** appears and emptying the water trap does not clear the INOP.

Changing Settings for the Gas Analyzer

To change general gas analyzer settings, enter the **Setup GM** menu:

- Select one of the gas analyzer numerics on the monitor screen and then select the menu item **Setup GM**, or
- Press the Setup hardkey on the gas analyzer.

To change settings for individual gases, enter the setup menu for the individual gas:

- Select the measurement numeric on the monitor screen, or
- Select the required gas label in the **Setup GM** menu.

Selecting Numerics for Display

For each gas the gas analyzer measures, you can select which numerics are displayed with the waveform on the screen:

- **et** displays the end-tidal numerics.
- **in** displays the inspiratory numerics.
- **et + in** displays both end-tidal and inspiratory numerics.
- **MAC** displays the minimum alveolar concentration of an anesthetic agent at which 50% of anesthetized patients do not respond with movement to a painful stimulus.
- **MACawak** (MAC awake) displays the minimum alveolar concentration of an anesthetic agent at which 50% of anesthetized patients respond to a verbal command.

To change the displayed numeric:

- 1 In the **Setup <Gas Label>** menu, select the label of the gas measured to display a pop-up list of numerics available.
- 2 Select the numeric you want to display.

As the inspired minimum is measured for CO₂, the numeric label is **im** instead of **in**.

Humidity Correction for CO₂

The gas analyzer is configured to correct the CO₂ measurement for either Body Temperature Pressure Saturated (BTPS), to account for humidity in the patient's breath, or Ambient Temperature Pressure Dry (ATPD).

In the **Setup CO₂** menu, check the menu item **Humidity Corr.** to see which correction is being applied. It is either **Wet** for BTPS or **Dry** for ATPD. By default, the **Humidity Corr.** should be set to **Dry**.

Refer to for details on the humidity correction.

Adjusting Wave Scales

- 1 In the wave menu or the setup menu for the gas, select **Scale**.
- 2 Choose a suitable scale range from the pop-up list.

Switching Off Individual Gas Measurements

To switch off a gas measurement:

- 1 In the **Setup <Gas Label>** menu, select the label of the gas.
- 2 In the pop-up list, select **Off**.

No waveforms or numerics will be shown for gases set to **Off**, and no alarms will be generated.

Deriving Limit Alarms from awRR

- 1 In the **Setup CO₂** menu or in the **Setup GM** menu, select **awRR**.
- 2 Select **Alarms**.
- 3 Select **On** to derive alarms from the airway respiration signal or **Off** to disable them.

Changing the Apnea Alarm Delay

WARNING

The gas analyzer is **not** an apnea monitor. The safety and effectiveness of the respiration measurement method in the detection of apnea, particularly the apnea of prematurity and apnea of infancy, has not been established.

The apnea alarm delay time determines the time limit after which the monitor alarms if the patient stops breathing.

- 1 In the **Setup CO₂** menu, select **awRR**.
- 2 In the **Setup awRR** menu, select **Apnea Time**.
- 3 Choose the apnea alarm delay time.

Automatic Alarm Suppression

Your monitor can be set to suppress alarms until it detects that a patient has been connected to the gas analyzer (when breathing is detected). This setting is called **No Al.til Breath** (No alarm until breath) and can be set to **On** or **Off** in the monitor's Configuration Mode.

Agent Identification

All respiratory gases are detected automatically, including automatic dual agent identification – two agents out of five.

As soon as the gas analyzer has detected an agent, a waveform and the numerics for this agent appear on the monitor screen, if they are configured to be displayed. During the process of identification, the generic labels **AGT1** and **AGT2** are shown as placeholders.

For an anesthetic agent to be detected by automatic agent identification, its concentration must exceed the identification threshold.

The single agent identification threshold is 0.15 Vol% typically and 0.3 Vol% at maximum for all anesthetic agents.

Agent mixture situations (more than one agent is present) are detected automatically by the gas analyzer. The agent mixture detection threshold for the second agent is as follows:

Maximum 0.4 Vol% of a second agent, except if a second agent is added to Desflurane. With Desflurane, the concentration of the second agent must exceed 10 Vol% of the current Desflurane concentration.

If more than two agents are detected at the same time, an **Agent Mixture** INOP is displayed, and the agent related measurements are marked invalid (-?-).

WARNING

The presence of other substances in the patient's breathing circuit such as ethanol, acetone, methanol, isopropanol, freon, asthma medication carrier gases and other IR absorbing gases can influence the agent identification and lead to incorrect values and incorrect identification.

Exchanging Agents

If the anesthetic agent administered to the patient changes, a mixture of both gases is detected during the transition. The time needed to complete the exchange depends on the type of anesthesia (low flow or high flow), and the characteristics of the agents administered (pharmacokinetics). During the exchange, you will see the INOP message **Agent Mixture**.

Agent Identification During Emergence from Anesthesia

If during emergence from anesthesia the agent concentration falls below the identification threshold, the gas analyzer will continue to provide a measured value for display on the monitor until a value near zero is reached. Once this value is reached, the agent label will remain on the display and the numeric will be unavailable (blank) until patient breathing is no longer detected. Then the generic label **AGT1/AGT2** will be shown.

MAC Calculation

The MAC (Minimum Alveolar Concentration) value of an anesthetic gas or agent denotes the concentration at which 50% of a population of anesthetized patients do not respond with movement to a painful stimulus (for example, a standardized incision through the skin). The MAC awake represents the concentration at which 50% of a population of anesthetized patients responds to verbal command.

Three configurable methods of MAC calculation are available:

- Uncorrected MAC
- Ambient Pressure Corrected MAC
- Enhanced MAC Correction

The preferred method must be set in Configuration Mode of your patient monitor. The total MAC and MACawak values can then be selected for display on your monitor. The sections below describe how these values are calculated with the different methods.

To switch the MAC and/or the MACawak parameter on, set **MAC** and /or **MACawak** to **On** in the gas analyzer setup menu.

Be aware that:

- The MACawak value can only be displayed if MAC Correction is configured to **Enhanced**.
- Ambient Pressure Corrected MAC and Enhanced MAC Correction are not available in the USA.

Uncorrected MAC

If the MAC Correction is configured to **Off** the uncorrected MAC is calculated. The MAC value is not corrected for ambient pressure, age, temperature or any other individual factors influencing the effect of volatile anesthetic agents.

In order to calculate the MAC value the standard 1.0 MAC concentrations of anesthetic agents and nitrous oxide are required. The following table lists these concentrations (according to the EN ISO 21647:2004 standard). The values are based on the assumptions that the patient is 40 years old (except for Desflurane where 25 years are assumed), the body temperature is 37°C and the atmospheric pressure is 760 mmHg (1 atm):

Agent	1.0 MAC
Halothane	0.77 vol%
Enflurane	1.7 vol%
Isoflurane	1.15 vol%
Desflurane	7.3 vol%
Sevoflurane	2.1 vol%
N ₂ O	105 vol%

For each volatile anesthetic agent detectable by the gas analyzer the MAC value for the specific agent (MAC(AA)) is calculated as follows:

$$\text{MAC(AA)} = \frac{\text{etConc(AA)}}{\text{IMAC(AA)}}$$

where AA = Anesthetic Agent and etConc = end-tidal concentration

In the same way, the MAC value for nitrous oxide (MAC(N₂O)) is derived from the measured value of the nitrous oxide end-tidal concentration (etConc(N₂O)):

$$\text{MAC(N}_2\text{O)} = \frac{\text{etConc(N}_2\text{O)}}{\text{IMAC(N}_2\text{O)}}$$

Finally, the total MAC value of nitrous oxide and the selected anesthetic agent is calculated as follows:

$$\text{MAC} = \text{MAC(N}_2\text{O)} + \text{MAC(AA)}$$

NOTE

Gas components (N₂O and/or anesthetic agent) which are switched off are not included in the total MAC computation.

Ambient Pressure Corrected MAC

If the MAC Correction is configured to **Amb.Pressure**, the MAC is corrected to reflect the effect of a different partial pressure at another altitude.

The total MAC value is calculated in the same way as for the uncorrected MAC and then corrected for ambient pressure according to the following equation:

$$\text{MAC} = \text{uncorrected total MAC} \times \frac{\text{Pamb}}{760\text{mmHg}}$$

Enhanced MAC Correction

If the MAC Correction is configured to **Enhanced**, the MAC value is corrected for age, temperature and ambient pressure.

The basic 1.0 MAC values used for enhanced MAC correction are listed in the table below. These values are taken from the scientific article "Age, minimum alveolar anaesthetic concentration and minimum alveolar anaesthetic concentration-awake" by Edmond I Eger II (Anesth Analg 2001, 93: 947-53) and differ slightly from the standard 1.0 MAC values used for the uncorrected MAC.

NOTE

There is no correction data available for Enflurane, so the standard 1.0 MAC value is used in this case.

For standard conditions as assumed for the uncorrected MAC the values are:

Agent	1.0 MAC
Halothane	0.757 vol%
Enflurane	1.7 vol% (no correction to uncorrected MAC)
Isoflurane	1.19 vol%
Desflurane	6.45 vol%
Sevoflurane	1.88 vol%
N ₂ O	114 vol%

The patient age can either be entered into the IntelliVue patient monitor, or provided by the information system if the monitor is networked. The patient temperature is obtained from a temperature measurement by the monitor. Only the following temperature labels are accepted for correction (listed in order of priority):

- 1 T_{core}
- 2 T_{blood}

Patient Age Range	1 to 100 years
Temperature Range	25 to 45°C

Any age or temperature value outside the supported ranges is restricted to the according lower or upper boundary.

If the patient age is not available, the MAC correction will assume a default age of 40 years. If none of the listed temperatures is measured, a default temperature of 37°C is taken for MAC calculation. In all of these cases the INOP **MAC Correction?** is issued and the MAC numerics are marked questionable.

The 1.0 MAC value for a specific potent inhaled anesthetic agent at age 40 (see table above) is corrected for patient age and temperature effects as follows (T given in degree Celsius and the age given in years):

$$1.0 \text{ MAC}_{\text{corr}}(\text{AA}) = (1 - ((0.05) \times (37 - T))) \times 1.0 \text{ MAC}(\text{AA}) \times 1.32 \times 10^{-(0.00303 \times \text{Age})}$$

With the 1.0 MAC value corrected for age and temperature at a standard pressure of 760 mmHg, the MAC value of an anesthetic agent can be calculated as follows:

$$\text{MAC}(\text{AA}) = \frac{\text{etConc}(\text{AA})}{\text{IMACcorr}(\text{AA})} \quad (\text{for all agents except Enflurane})$$

$$\text{MAC}(\text{ENF}) = \frac{\text{etConc}(\text{ENF})}{\text{IMAC}(\text{ENF})} \quad (\text{for Enflurane})$$

The MAC value of nitrous oxide is obtained from the 1.0 MAC concentration of nitrous oxide at age 40 corrected for the patient's age only (no correction is made for temperature):

$$\text{MAC}(\text{N}_2\text{O}) = \frac{\text{etConc}(\text{N}_2\text{O})}{\text{IMAC}(\text{N}_2\text{O}) \times 1.378 \times 10^{-(0.00347 \times \text{Age})}}$$

The total MAC value for the combination of nitrous oxide plus the selected agent is obtained by adding the MAC value for the agent and the MAC value for nitrous oxide and correcting this sum for ambient pressure:

$$\text{MAC} = [\text{MAC}(\text{N}_2\text{O}) + \text{MAC}(\text{AA}) \text{ or } \text{MAC}(\text{ENF})] \times \frac{\text{Pamb}}{760\text{mmHg}}$$

Gas measurements which are switched off, are not included in the total MAC computation. The calculated MAC values for a 40 year old patient at a temperature of 37°C are similar but not identical to the 1.0 MAC values given in the table for uncorrected MAC configuration.

In addition, the MAC_{awk} values can be determined as follows:

$$\text{MAC}_{\text{awk}}(\text{AA}) = \frac{\text{MAC}(\text{AA})}{0.343} \quad (\text{for all agents except Halothane})$$

$$\text{MAC}_{\text{awk}}(\text{HAL}) = \frac{\text{MAC}(\text{HAL})}{0.551} \quad (\text{for Halothane})$$

$$\text{MAC}_{\text{awk}}(\text{N}_2\text{O}) = \frac{\text{MAC}(\text{N}_2\text{O})}{0.551} \quad (\text{for nitrous oxide})$$

The total MAC_{awk} value is obtained by adding the individual MAC_{awk} values up:

$$\text{MAC}_{\text{awk}} = \text{MAC}_{\text{awk}}(\text{N}_2\text{O}) + \text{MAC}_{\text{awk}}(\text{AA}) \text{ or } \text{MAC}_{\text{awk}}(\text{HAL})$$

Entering Gas Analyzer Standby Mode

During standby, the gas analyzer's gas sample intake pump and other internal components are automatically switched off to increase the lifetime of the device. The message **GM Standby** is shown on the monitor. When you exit standby, the gas analyzer requires up to 30 seconds warmup time before you can resume monitoring.

The gas analyzer enters standby mode automatically when no breath is detected for a configured period of time (if CO₂ goes below the adaptive threshold).

The gas analyzer standby mode is linked to the monitor standby mode:

- If the monitor enters standby mode, the gas analyzer also enters standby mode.
- If the monitor leaves standby mode, the gas analyzer automatically also leaves standby mode.
- If the gas analyzer enters standby mode, this does not affect the monitor.
- If the gas analyzer and monitor are both in standby mode, pressing the Standby or Setup key on the gas module will cause the monitor to leave standby mode.

If the gas analyzer is in a mode where entering or leaving standby is not possible (for example zeroing mode), it will enter or leave standby as soon as possible.

Entering Standby Mode

To enter standby mode manually: in the **Setup GM** menu, select **Set to Standby** or press the Standby hardkey on the gas analyzer.

Exiting Standby Mode

To exit standby mode manually: in the **Setup GM** menu, select **GM Exit Standby** or press the Standby hardkey on the gas analyzer.

Zero Calibration

A zero calibration is always performed automatically and does not require any interaction.

The gas analyzer zero calibration maintains the accuracy of the gas measurements by sampling and analyzing room air. If the sample gas is returned to the breathing system this will result in room air being introduced into the breathing system.

Zero calibration takes about 21 seconds to complete and must not be interrupted. While a zero calibration is running, a **GM Zero Running** INOP is displayed.

Under normal conditions a zero calibration is performed every 24 hours. Additionally a zero calibration is performed:

- approximately 30 minutes after the gas analyzer is plugged in or the monitor is switched on, after the warmup phase.
- after leaving standby mode, depending on the length of time spent in standby.

If a zero calibration fails, one or two further zero calibration attempts may be performed automatically. If all the zero calibration attempts fail, a **<Gas Analyzer> Zero Failed** INOP is displayed. During the zero calibration, the waveform is flat and numerics are not updated.

If necessary, the zero calibration can be suppressed for 5 minutes.

Alarms (During Zero Calibration)

When a zero calibration is in progress, the physiological alarm detection is suspended. When the calibration is finished, the gas analyzer resumes alarm detection. If an alarm condition is present after the zero calibration, the alarm will be activated within the specified alarm delay time.

WARNING

If an apnea occurs during a normal zero calibration, the time delay between the start of apnea and the activation of the apnea alarm could be up to 20 seconds plus the configured apnea delay time.

If a zero calibration is started while an apnea alarm is active, all numerics except awRR are marked invalid (-?- is displayed instead of the numerics). The awRR numeric is still displayed but is marked as unreliable with a ? next to the numeric.

Suppressing Zero Calibration

You can delay the automatic zero calibration for 5 minutes.

To temporarily prevent an automatic zero calibration from being started, in the **Setup GM** menu, select **No Zero for 5min**. A **Gas Analyzer zero cal suppression activated** message is displayed. After 5 minutes the zero calibration will be performed. A further delay is not possible.

Using the Gas Analyzer During a Cardiopulmonary Bypass

CAUTION

During a cardiopulmonary bypass, the anesthesiologist may cease periodic mechanical ventilation. In these cases, be aware that an active gas analyzer will continue to draw gases from the patient-ventilator circuit during that time. This will cause the airway pressure to drop if no active measures are taken to keep the patient-ventilator circuit stable.

To stop the gas analyzer from drawing gases out of the circuit, either activate the gas analyzer standby mode or disconnect the gas sample tubing from the gas analyzer or from the patient-ventilator circuit.

Gas Analyzer Safety Information

WARNING

Warmup Time: Until the gas analyzer has reached its operating temperature the measurement accuracy may be reduced. Allow two and a half minutes warmup to reach specified accuracy. Refer to for further information regarding measurement accuracy.

Cross-Infection: There is a risk of patient cross-infection if the sampled gas is returned to the breathing system.

Detecting leaks: Any leak in the tubing and connections from the patient to the gas analyzer may result in dilution of the gas mixture with ambient air. If this leak exceeds a certain magnitude, the value of gases and anesthetic agents displayed on the monitor may differ significantly from the actual concentration in the patient's breathing circuit. Erroneous values may lead to inappropriate intervention and patient safety may be at risk.

Unexpected values: If an unexpected gas concentration value appears on the monitor, or if the waves appear to be flatter than normal, visually inspect the entire tubing and replace if necessary. If no occlusion or leakage can be found, replace the water trap with a new one and check the values.

With unexpected high CO₂ values, check if the ventilator CO₂ absorber is full.

Be aware of the accumulation of volatile foreign substances inside the circuit during low flow anesthesia. This occurs in part as a consequence of the metabolism of anesthetic agents, and in part as a result of the physiological catabolic cascade. Flushing the circuit with fresh gas at regular intervals may be necessary, especially if a decrease in the O₂ concentration is measured.

CAUTION

Do not store or operate the gas analyzer outside the storage and operating conditions specified.

Do not expose the gas analyzer to excessive heat or sunlight as this could lead to overheating of the instrument and result in injuries.

Avoid any restriction or blockage of air flow as this could cause overheating of the gas analyzer and result in injuries.

Mechanical vibrations or shock may have adverse effects on gas measurement values.

Use both hands when plugging-in/removing the gas analyzer module from the module slots; the module weighs approximately 1 kg (2.2 lbs).

Use Environment

WARNING

Explosion Hazard: Do not use in the presence of flammable anesthetics or gases. Use of the device in such an environment may present an explosion hazard.

Do not place the device into operation if oxygen leakage is suspected in the vicinity. Stop all oxygen supplies and contact service personnel.

Risk of Fire: Do not introduce drugs or other substances based on flammable solvents, such as alcohol, into the device and do not use explosive anesthetic agents such as ether or cyclopropane or spray them into the device. If highly flammable substances are used for disinfection, adequate ventilation is required.

Make sure that the medical device is placed at least 25 cm (10 in) from any ignition sources such as electrosurgery and laser surgery.

Indications for Use

The IntelliVue G7m Gas Analyzer Module in combination with the modular IntelliVue patient monitors is indicated for use by health care professionals whenever there is a need for monitoring the physiological parameters of ventilated or intubated patients (adults, pediatrics, and neonates).

Monitoring Intravascular Oxygen Saturation

Depending on the probe or catheter used and the measurement location, the SO_2 module measures the central venous oxygen saturation or mixed venous oxygen saturation continuously and invasively.

WARNING

Injected dyes, such as methylene blue, or intravascular dyshemoglobin may lead to inaccurate measurements.

Do not monitor oxygen saturation during infusion of I.V. fat emulsion or other turbid substances through the distal lumen of the OptiCath catheter. These liquids might temporarily modify the blood scattering and absorption characteristics at the catheter tip. This interferes with the optical measurement of oxygen saturation. After infusion is complete, you can again monitor oxygen saturation accurately.

During injection of the bolus for thermodilution cardiac output measurements, the SvO_2 measurement might be disturbed.

Explosion Hazard: Do not use in the presence of flammable anesthetics or gases, such as a flammable anesthetic mixture with air, oxygen or nitrous oxide. Use of the devices in such an environment may present an explosion hazard.

Do not use probes/catheters when they, or the packaging, are damaged.

Always select the correct label for the measurement location and the catheter/probe in use. This is especially important when ProtocolWatch is in use, to ensure that the correct limits are used for the criteria applied.

CAUTION

Use the module with Philips approved accessories only. Refer to the instructions for use provided with the accessory.

Selecting a Measurement Label

Always select a measurement label before inserting a catheter/probe.

Use the SvO_2 label when the catheter/probe will be located in the pulmonary artery (measuring mixed venous oxygen saturation). This is the only label which allows the measurement value to be used to calculate oxygen extraction (see “Calculating Oxygen Extraction” on page 308) and in the standard oxygen calculations.

Use the $ScvO_2$ label when the catheter/probe will be located in a central vein (measuring central venous oxygen saturation).

Use the SO_2 label in all other cases.

To select a measurement label:

- 1 Select **Main Setup** then **Measurements** followed by **<SO₂ Label>**
- 2 Select **Label**.
- 3 Select the appropriate label for the catheter/probe location.

Preparing to Monitor with the M1011A SO₂ Module

In addition to the module, you need a Philips SO₂ Optical Module and a compatible fiber optic probe or catheter. Use only the accessories listed as applicable for the intended measurement location in the Accessories section.



Connecting the Optical Module

- 1 Connect the optical module to the SO₂ module. Allow the optical module to warm up before you insert the probe/catheter and perform a calibration.
Although the warmup message disappears from the screen after one minute, it is preferable to let the optical module warm up for 10 minutes for best accuracy.
- 2 Place the optical module on the catheter tray in the space provided and open the lid.
- 3 Insert the SO₂ probe/catheter connector into the socket in the optical module until it snaps into place.
- 4 Close the lid.
- 5 For instructions on the placement of fiber optic catheters/probes, refer to the documentation provided with the accessory.

After Insertion

The SO₂ probe/catheter is thin and flexible, treat it carefully. Avoid kinking, bending or grasping the probe/catheter with forceps or a hemostat. Damage to the fiber results in low intensity light and a sudden decrease in intensity readings. Refer to the documentation provided with the fibre-optic probe/catheter, paying special attention to any precautions, warnings or contraindications.

Secure the optical module directly attached or in close proximity to the patient, to avoid placing excessive tension on the catheter, which would result in movement of the catheter tip from the optimal position in the patient.

Position the optical module to avoid contact with liquids. Fluid entering the catheter-optical module connection will impair measurement performance.

You **must** perform an in-vivo calibration once the probe/catheter is in place.

The probe/catheter should be replaced after it has been in place for 72 hours.

CAUTION

Do not apply excessive tension to any cable or part of the catheter.

Performing In-Vivo Calibration

Perform an in-vivo calibration:

- when you place the catheter in a patient.
- if the catheter was disconnected from the optical module.
- when the catheter has been in the patient for 24 hours.
- if any significant change in light intensity occurs that the monitor cannot correct automatically.

Setting Up the In-Vivo Calibration

Check for:

- proper positioning of the probe/catheter in the patient.
- relatively stable oxygen saturation in patient.
- that the light intensity indicator is indicating a stable medium to high level.

Depending on the probe/catheter in use you may need to enter a catheter correction factor. This can be found printed on the connector of the probe/catheter. The correction factor must only be entered if it is different from the one currently stored. To see the current correction factor:

- 1 In the **Setup <SO₂ Label>** menu, select **Catheter Factor**.
- 2 If the correction factor displayed is different from the one on the connector, note the correction factor from the probe/catheter for entry during calibration.

Making the In-Vivo Calibration

- 1 Be prepared to draw a blood sample from the patient.
- 2 In the **Setup <SO₂ Label>** menu, select **Start In-VivoCal**.
- 3 To clear the distal lumen, draw off and discard at least 2 ml of blood before taking the sample.
- 4 Draw a blood sample from the distal port of the catheter and flush the line according to standard hospital practice.
- 5 Obtain laboratory analysis of the sample using direct measurements.
- 6 Select **CalibrationValue** and select from the list the value received from the lab.
- 7 Select **Hct [%]** (or **Hb [mmol/l]** or **Hb [g/dl]**) depending on the set up) and enter the corresponding value from the laboratory analysis.
To change the setup for entering the Hb/Hct, see “Changing the Lab Value Required for Entry” on page 308 below.
- 8 If you need to enter a new correction factor, select **Catheter Factor**.
- 9 Enter the correction factor.
- 10 Complete the calibration by selecting **Store In-VivoCal** (even if the stored calibration value did not change) and select **Confirm**. This updates the data stored in the optical module.
Selecting **Recall Last Cal** recalls the previously stored calibration value.

If the calibration fails, check that the light intensity indicator is indicating a stable medium to high level. Repeat the calibration.

Changing the Lab Value Required for Entry

You can change the lab value required to be entered: **Hb [g/dl]**, **Hb [mmol/l]** or **Hct [%]**.

- 1 In the **Setup <SO₂ Label>** menu, select **Hb/Hct Entry**.
- 2 Select your preferred lab value and unit.

Checking Suspicious Values

If you have any doubts about the correctness of the measurement value, take a blood sample and have it analyzed using standard laboratory procedures.

Calculating Oxygen Extraction

Oxygen extraction is the difference between the measured SpO₂ and SvO₂ values. If you are monitoring SpO₂ and SvO₂, the monitor can calculate this value and display it as a numeric.

- To switch oxygen extraction calculation on or off, in the **Setup Sp-vO₂** menu, select **Sp-vO₂** and toggle between **On** and **Off**.
- If more than one SpO₂ value is available, you must choose which value is used in the calculation. In the **Setup Sp-vO₂** menu, select **SpO₂ Source** and select the required source.

If one of the calculation sources becomes unavailable, the monitor displays the **INOP Sp-vO₂ Chk Sources** for one minute. After this time, the calculation automatically switches off. If the missing source becomes available again, the calculation automatically switches on again.

Monitoring EEG/aEEG

The M1027B Electroencephalograph (EEG) module monitors the patient's cerebral function by measuring the electrical activity of the brain. It provides the monitor with up to four channels of realtime EEG waves depending on the choice of trunk cables used. The monitor automatically detects whether a two or four channel trunk cable is connected. The EEG/aEEG module provides EEG trend information in the form of Amplitude Integrated EEGs (aEEG), Compressed Spectral Arrays (CSA), and up to nine of the following numerics:

Spectral Edge Frequency (SEF) - The SEF is the frequency below which a defined percentage of the Total Power lies. The percentage is set in Configuration Mode.

Mean Dominant Frequency (MDF) - The MDF is the amplitude-weighted average over the selected frequency band.

Peak Power Frequency (PPF) - The PPF is the frequency with the highest measured amplitude.

Total Power (TP) - The TP numeric indicates the power in the measured frequency band.

Percentage of total power in each frequency band:

- **Alpha** waves (8 to 13 Hz)
- **Beta** waves (13 to 30 Hz)
- **Theta** waves (4 to 8 Hz)
- **Delta** waves (0.5 to 4 Hz).

Burst Suppression Ratio (BSR) - Percentage of 0.512 seconds periods with an amplitude below 10 μ V in a 65.536 seconds (128 periods) window.

EEG/aEEG Monitoring Setup

- 1 Plug the trunk cable into the EEG/aEEG module.
- 2 Prepare the patient's skin prior to placing the electrodes. Good electrode-to-skin contact is important for a good EEG signal, as the skin is a poor conductor of electricity.
 - Shave hair from sites, if necessary.
 - Wash sites thoroughly with soap and water. We do not recommend using ether or pure alcohol, because this dries the skin and increases the resistance.
 - Use a skin preparation paste to remove skin cells and oil before placing the electrodes.
- 3 Select the desired electrode montage in the **Setup EEG** menu or in the **EEG Impedance / Montage** window.
- 4 Attach the reference electrode first.
- 5 Place the electrodes on the patient's head according to the selected montage. Use electrode gel if you are not using pre-gelled electrodes. Remember to select a site where the signal will not be interfered with by muscle artifacts.
- 6 Connect the electrode connector end to the trunk cable.
- 7 Check the electrode-to-skin impedance in the **EEG Impedance / Montage** window.
- 8 For good signal quality, keep all lead wires together and away from other electric devices and metallic bodies.

Using the EEG Impedance/Montage Window

To open the window, in the **Setup EEG** menu, select **Show Montage**, or select the **EEG Montage** SmartKey. The window may be configured to look slightly different on your monitor.

Four Channels

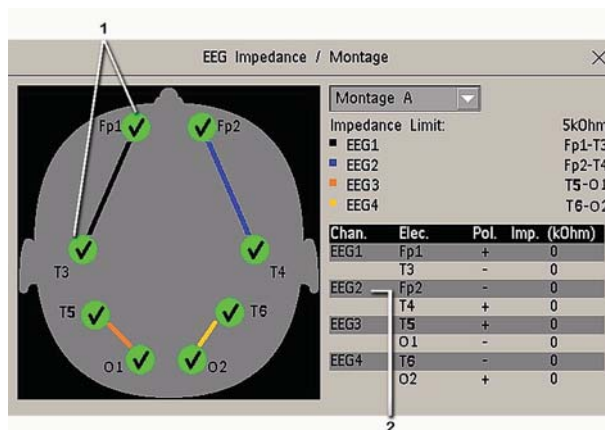

- 1 Electrode locations on the patient's head. The symbols represent the electrode-to-skin impedance.
- 2 Wiring and impedance values for the selected montage.

Choosing an EEG Electrode Montage

- 1 To activate one of the five pre-configured electrode montages, select the arrow beside the label in the **EEG Impedance / Montage** window and choose a montage from the list.
- 2 Attach the electrodes as illustrated in the **EEG Impedance / Montage** window.

The five default electrode montage configurations can be modified and renamed in Configuration Mode.

Electrode	Montage A	Montage B	Montage C	Montage D	Montage E
EEG1+	Fp1	F3	O1	F3	C3
EEG1-	T3	P3	T3	C3	P3
Label1	Fp1-T3	F3-P3	O1-T3	F3-C3	C3-P3
EEG2+	Fp2	F4	O2	F4	C4
EEG2-	T4	P4	T4	C4	P4
Label2	Fp2-T4	F4-P4	O2-T4	F4-C4	C4-P4
EEG3+	T5	P3	O1	F3	C3
EEG3-	O1	P4	T3	C3	P3
Label3	T5-O1	P3-P4	O1-T3	F3-C3	C3-P3
EEG4+	T6	P3	O2	F4	C4
EEG4-	O2	P4	T4	C4	P4
Label4	T6-O2	P3-P4	O2-T4	F4-C4	C4-P4

The electrode locations are labeled according to the international 10-20 electrode placement system.

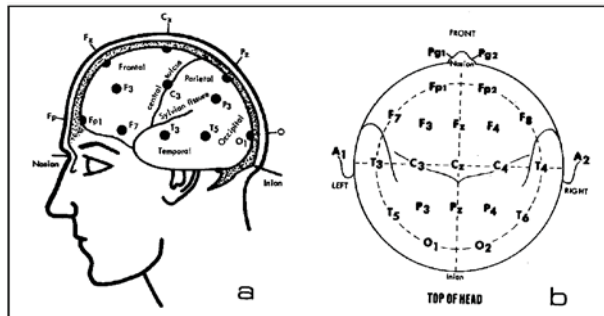

Changing the Impedance Limit

The impedance limit can be set for all electrodes simultaneously in the **Setup EEG** menu, or in the **EEG Impedance / Montage** window using the pop-up keys. If the limit is exceeded during monitoring, an INOP will appear and the graphic impedance indicator will change.

To change the impedance limit, either

- use the pop-up keys that appear with the **EEG Impedance / Montage** window, or
- in the **Setup EEG** menu, select **Impedance Limit** to call up a list of selections between 0 and 30 kOhm, then select the required limit from this list.

About Electrode-to-Skin Impedance

Electrode-to-skin impedance is the main quality indicator for the measured EEG signal. During normal EEG monitoring, electrode-to-skin impedance is measured continuously and disconnected electrodes are detected. The impedance value for each single, independent signal electrode is displayed in the **EEG Impedance / Montage** window. If the measured electrode-to-skin impedance of one or more electrodes is above the limit, an INOP will be issued.

For impedance measurement at least two electrodes, plus the reference electrode, must be connected.

Impedance Indicators

Electrode/Skin Impedance	Symbol	Color	Displayed Impedance Value	Action
Electrode not connected	✘	red	no value	connect electrode
Noisy signal	?	gray	60 k Ω (fixed)	check electrode-to-skin connections
Electrode connected, impedance above limit	⬆	yellow	measured value (e.g. 15 k Ω)	check limit, check electrode-to-skin contact
Electrode connected, impedance at or below limit	✔	green	measured value (e.g. 3 k Ω)	no action necessary

About Compressed Spectral Arrays (CSA)

There are CSA presentations optimized for two and four channels.

The continuous EEG signal is sampled periodically and this value is stored in a frame. Each frame is processed using Fast Fourier Transformation (FFT) to provide a frequency spectrum displayed as a compressed spectral array (CSA).

The CSA window provides an overview of the patient's EEG values over time. It may be configured to look slightly different on your monitor.

- To view the CSA window permanently embedded on a Screen, select a Screen configured to display the CSA window.
- To view the CSA window over the current screen, select the **EEG CSA** SmartKey, if configured, or select **Setup EEG** or **Main Setup** then **Show CSA**.

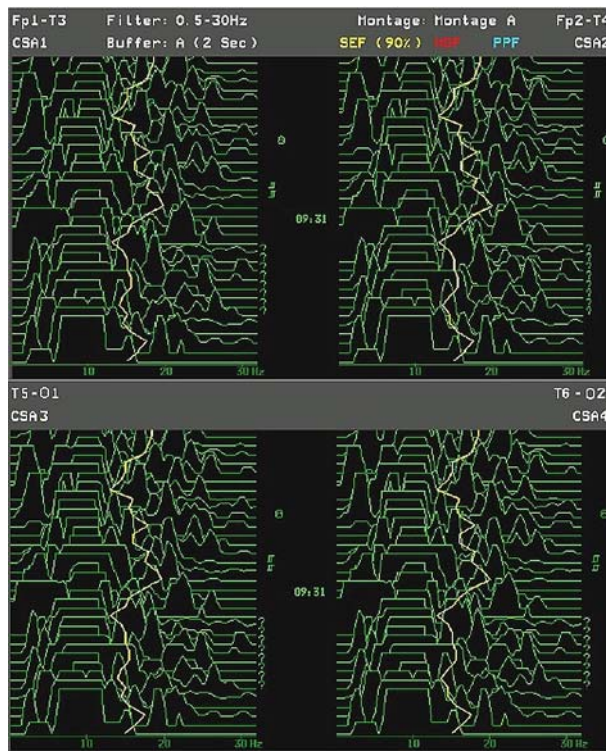

The CSA contains the following information		
Status line	Lead label	for example, Fp1-T3, Fp2-T4
	CSA label	CSA1 to CSA4 according to EEG channel
	Montage label	for example, Montage A
	Filter settings	for example, 0.5-30 Hz
	Buffer label and time	the buffer and interval between spectral lines on the CSA
	Current SEF Threshold	can only be changed in Configuration Mode
Spectral lines	The energy at each frequency is computed and displayed as a spectral line.	
Trendlines	EEG values are sampled at configured time intervals and displayed as color-coded trendlines. Trendlines are available for the three frequency numerics (SEF, PPF, MDF).	
Annotations	?	INOP marker
	⏏	Filter change marker
	Ⓐ	Montage change marker

Changing CSA Settings

When CSAs are shown embedded on the Main Screen, select the CSA to show the pop-up keys. When the CSA is shown in a window over the current screen, the pop-up keys are always displayed.

Setup CSA Window	This menu entry lets you
Buffer	Choose one of the two pre-configured buffers. A buffer defines the interval between the spectral lines displayed in the CSA.
On/Off SEF On/Off MDF On/Off PPF	Switch the trendline of the specific numeric on or off.

Changing EEG Settings

Be aware that any changes made to EEG settings apply to all EEG channels.

Switching EEG Numerics On and Off

Each EEG numeric can be individually switched on or off in the **Setup EEG** menu.

- 1 In the **Setup EEG** menu, select the numeric label.
- 2 Select **On** or **Off** to switch between the settings.

Changing the Scale of the EEG Waves for Display

This only changes the visual appearance of the wave. It does not affect the signal analyzed by the monitor or printed in reports or recordings.

- 1 In the **Setup EEG** menu, select **Wave Scale** to call up a list of wave scales.
- 2 Select the required scale from this list.

Scaling information is displayed with each EEG wave.

- If **Show Gridlines** is set to **On** in Configuration Mode, gridlines and the current wave scale values are shown with the EEG wave.
- If **Show Gridlines** is set to **Off** in Configuration Mode, the current wave scale is indicated by a size bar beside the EEG wave.

Changing Filter Frequencies

The low and high pass filters screen out undesirable interference from the raw EEG wave display. The current EEG filter frequency settings are shown in the header of the CSA. Changing filter settings affects the EEG wave and all the EEG numerics. Whenever the filter setting is changed, a filter change marker appears next to the spectral lines.

To change the filter settings:

- 1 In the **Setup EEG** menu, select **Low Filter** or **High Filter** to call up a list of available frequencies.
- 2 Select the required frequency from this list.

Changing the Speed of the EEG Wave

The EEG measurement has its own speed control and is not affected by the wave speed settings of the other measurements.

In the **User Interface** menu, select **EEG Speed**. Choose the required speed from the pop-up list. This defines the speed at which the wave is drawn across the screen in millimeters per second (mm/s).

About aEEG

The aEEG presentation is a trend display of the amplitude-integrated EEG (aEEG). It uses amplitude compression, i.e. the vertical scale is linear from 0 to 10 μ V and logarithmic above 10 μ V. It is written at 6 cm/hour (horizontal scale). The vertical ranges are 0 to 100 μ V, 0 to 200 μ V and 0 to 400 μ V. The aEEG presentation is optimized for two and four channels.

A trend of the sum of the electrode impedances of the respective lead is shown below the aEEG presentation as a quality indicator that supports interpretation of the aEEG. The vertical range is 0 to 20 kOhm.

The monitor stores up to 24 hours of aEEG and electrode impedances for all 4 channels. These data can be navigated with the arrow pop-up keys when the aEEG is displayed.

- To view the aEEG window permanently embedded on a screen, select a screen configured to display the aEEG window.
- To view the aEEG window over the current screen, select the **aEEG** SmartKey, if configured, or select **Setup EEG** or **Main Setup** then **Show aEEG**.

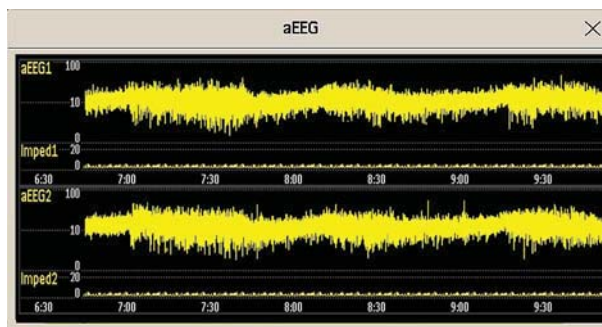

Changing the Scale of the aEEG

Be aware that any changes made to aEEG settings apply to all EEG channels.

- 1 In the **Setup EEG** menu, select **aEEG Scale** to call up a list of scales.
- 2 Select the required scale from this list.

Scaling information is displayed with each aEEG.

Using Two or Four Channels

If you always use two channels, have the default Montage configured to one with two channels, to optimize the display of the data.

If you switch between four channels and two channels, you will still see all four channels displayed until no more four-channel data is in the database. Depending on the size of the database configured, this may take up to 24 hours.

EEG Reports

The content of EEG Reports is always the same and does not need to be configured.

To print an EEG Report, in the **Setup EEG** menu, select **Print Report**.

Alternatively, you can select the CSA and use the **Print Report** pop-up key to start the report.

To modify the buffer and trendline settings on the CSA Report, in the **Reports** menu, select **CSA on EEG Rep.** If you do not change these settings, the monitor will use the default settings with the trendlines for the SEF numeric on and the buffer time from Buffer B.

CSA on EEG Rep.	This menu entry lets you
Buffer	Choose one of the two pre-configured buffer times.
Trend SEF Trend MDF Trend PPF	Switch the trendline of the specific numeric on or off.

EEG Safety Information

WARNING

Do not touch the patient, or table, or instruments during defibrillation.

When connecting electrodes and/or patient cables, ensure that the EEG leads and connectors do not come into contact with other conductive parts or earth.

High-frequency Surgery - To reduce the hazard of burns, the EEG electrodes should not be located between the surgical site and the electrosurgical unit return electrode.

EEG and Electrical Interference

CAUTION

Implanted devices (e.g. cardiac pacemakers), other patient-connected equipment, and other equipment near the patient (e.g. high-frequency surgical units) can cause interference on the waveform, numerics, and the CSA and aEEG presentations.

Interference from ECG can be eliminated by adjusting the low filter settings.

Monitoring BIS

Bispectral Index monitoring helps to monitor the level of consciousness of a patient under general anesthesia or sedation in the OR and ICU. The BIS sensor is placed on the patient's forehead to capture electroencephalographic (EEG) signals from which several numerics are derived, including a single BIS value representing the level of consciousness. If you are using the 4-channel BIS device and the respective BIS sensor, you can make bilateral BIS measurements. See the “Specifications” chapter for the BIS intended use statement.

The BIS Module provides the monitor with an EEG wave and the following numerics:

Bispectral Index (BIS). The **BIS** numeric reflects the patient’s level of consciousness. It ranges from 100 (fully awake) to 0 (suppression; no electrical brain activity).

Signal Quality Index (SQI). The **SQI** numeric reflects signal quality and provides information about the reliability of the BIS, SEF, TP, SR, and Bursts numerics during the last minute.

It ranges from 0 to 100%:

SQI < 15%: the numerics cannot be derived

SQI 15% to 50%: the numerics cannot be reliably derived

SQI 50% to 100%: the numerics are reliable.

Electromyographic Activity (EMG). The **EMG** numeric reflects the electrical power of muscle activity and high frequency artifacts.

EMG < 55 dB: this is an acceptable EMG

EMG ≤ 30 dB: this is an optimal EMG

(note that the minimum possible EMG is approximately 25 dB).

Suppression Ratio (SR). The **SR** is the percentage of time over the last 63-second period during which the EEG is considered to be in a suppressed state.

Spectral Edge Frequency (SEF). The **SEF** is the frequency below which 95% of the Total Power is measured.

Total Power (TP). The **TP** numeric indicates the power in the frequency band 0.5 to 30 Hz. The typical range is 30 - 100 dB.

Bursts (with the Extend sensor only). The **Bursts** numeric helps you quantify suppression by measuring the number of EEG bursts per minute, where an EEG burst is defined as a period of activity followed and preceded by inactivity (at least 0.5 second).

Asymmetry (Asym) (bilateral systems only). The **Asym** numeric indicates an asymmetry between the activity of the left and right hemispheres of the brain.

NOTE

In bilateral BIS measurements values either from the left or the right hemisphere of the brain are displayed, depending on the selected hemisphere. This is indicated by an "L" or an "R" next to the numeric label (e.g. BIS L or BIS R). Asymmetry is always displayed in relation to the hemisphere selected and is therefore always marked with an "L" or an "R".

BIS Monitoring Setup



- 1 BIS module
- 2 BIS device
- 3 Patient interface cable
- 4 BIS sensor

- 1 Connect the BIS device to the BIS module
- 2 Use the clip on the rear of the BIS device to affix it in a position convenient for your patient, not above the patient's head.
- 3 Attach the BIS sensor to the patient following the instructions supplied with the sensor. Make sure that the patient's skin is dry. Be aware that a wet sensor or a salt bridge may cause erroneous BIS and impedance values. A variety of sensors are available for use in the OR and ICU environments.

CAUTION

Ensure that the BIS device does not come into prolonged contact with your patient's skin, as it may generate heat and cause discomfort.

The BIS device may remain connected to a patient during defibrillation as long as the sensor is not located between the defibrillator pads.

- 4 Attach the patient interface cable to the BIS device.
- 5 Connect the BIS sensor to the patient interface cable.

As soon as a valid sensor is detected, the impedances of all electrodes are measured automatically and the results are shown in the BIS window.

Manufacturer's Information

The BIS device, the patient interface cable and the BIS sensors are manufactured by Covidien llc.

BIS Signal Quality Indicator and EMG Indicator

The BIS numeric is displayed together with a signal quality indicator and EMG indicator (if enough space is available). The signal quality indicator gives an indication of the reliability of the displayed values. The level to which the triangle is filled shows the quality of the signal; the indicator below shows a high signal quality, the signal quality is at a maximum when the triangle is completely filled.

The EMG indicator is a bar graph which gives a graphical representation of the electromyographic activity. The lower end of the graph corresponds to 25 dB and the upper end to 55 dB. The horizontal line corresponds to 30 dB - below this line is the optimal range.



BIS Continuous Impedance Check

This checks:

- the combined impedance of the signal electrodes plus the reference electrode.

This is done continuously and does not affect the EEG wave. As long as the impedances are within the valid range, there is no notification of this check or its results.

- the impedance of the ground electrode.

This is done every ten minutes and takes approximately 4 seconds. It causes an artifact in the EEG wave, and the message **Ground Check** is shown on the monitor screen during the check. If the ground electrode does not pass this check, another check is started. This continues until the ground electrode passes the check.

If the Continuous Impedance Check interferes with other measurements, it can be switched off. To do this:

- 1 In the **Setup BIS** menu, select **Cont. Imp. Check**.
- 2 Select **On** or **Off** as required.

CAUTION

Switching the continuous impedance check off will disable automatic notification to the user of impedance value changes, which may lead to incorrect BIS values. Therefore, this should only be done if the check interferes with or disturbs other measurements.

BIS Sensor Check

This measures the exact impedance of each individual electrode. It causes a disturbed EEG wave, and the INOP **BIS Sensor Check** is shown on the monitor screen during the check.

Starting a Sensor Check

The sensor check is automatically started when a sensor is connected. To manually start a sensor check:

- select **Sensor Check** in the **Setup BIS** menu to switch between **On** and **Off**, or
- select **Start Sensor Chk** in the BIS window.

Stopping a Sensor Check

The sensor check stops automatically if the impedances of all electrodes are within the valid range. To manually stop a sensor check:

- select **Sensor Check** in the **Setup BIS** menu to switch between **On** and **Off**, or
- select **Stop Sensor Chk** in the window.

If you stop a sensor check before the ground electrode has passed, a ground electrode impedance check will be started automatically. This cannot be switched off.

BIS Window

To open the BIS window, in the **Setup BIS** menu, select **Show Sensor**.

The window may look slightly different on your monitor. The graphic in the BIS Window automatically adapts to show the type of sensor you are using, showing the number of electrodes as required. Each symbol in the graphic represents an electrode and illustrates the most recently-measured impedance status of the electrodes. Although BIS may still be measured when the electrode status is red or yellow, for best performance, all electrodes should be green.

In addition, if the measured electrode-to-skin impedance of any electrode or electrode combination is above the limit, or if disconnected electrodes are detected, an INOP will be issued, either **BIS High Impedance** or **BIS Lead Off**.

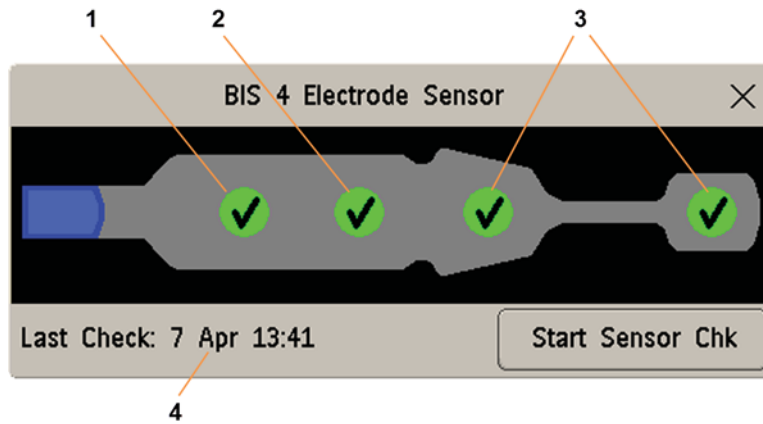

- 1 Reference Electrode
- 2 Ground Electrode
- 3 Signal Electrode(s)
- 4 Time of the most recent sensor check

BIS Impedance Indicators

Electrode-to-Skin Impedance	Symbol	Color	Action
Electrode has no skin contact	✘	red	Reconnect electrode, or check the sensor-to-skin contact. If necessary, clean and dry skin.
Too much signal noise, impedance cannot be measured	?	gray	Check sensor-to-skin contact. Press sensor more firmly to skin. If necessary, clean and dry skin.
Impedance above limit	⚠	yellow	Check sensor-to-skin contact. Press sensor more firmly to skin. If necessary, clean and dry skin.
Impedance within valid range	✓	green	No action necessary

Depending on your configuration, in addition to the symbols, the impedance value in kOhm may be displayed.

Bilateral BIS Measurements

If you are using the 4-channel BIS device and the respective BIS sensor, you can make bilateral BIS measurements. To select the hemisphere of the brain of which you want the values displayed on the monitor, in the **Setup BIS** menu, select **Values from** then choose either **Left** or **Right**.

NOTE

TP and SEF are always available for both hemispheres during bilateral measurements.

Changing the BIS Smoothing Rate

The smoothing rate defines how the monitor averages the BIS value.

To change the smoothing rate, in the **Setup BIS** menu, select **Smoothing Rate** then choose either:

- 10 sec
- 15 sec
- 30 sec

A lower smoothing rate provides increased responsiveness to changes in the patient's state. A higher smoothing rate provides a smoother BIS trend with decreased variability and sensitivity to artifacts.

Switching BIS and Individual Numerics On and Off

To switch the BIS measurement on or off:

- In the **Setup BIS** menu, select **BIS** and then **On** or **Off** as required.

To switch individual numerics provided by the BIS Module on or off:

- In the **Setup BIS** menu, select **SQI**, **TP**, **SEF**, **SR**, **EMG**, **Bursts**, or **Asym** and then **On** or **Off** as required.

Changing the Scale of the EEG Wave

Changing the scale only changes the visual appearance of the wave. It does not affect the signal analyzed by the monitor or printed in reports or recordings.

The scale information shown depends on whether gridlines are switched on or off for display. This setting can only be changed in Configuration Mode.

- 1 In the **Setup BIS** menu, select **Scale** to call up a list of wave scales.
- 2 Select the required scale from this list.
 - When gridlines are switched off, you can choose from the available scale values: 50 μ V, 100 μ V, 200 μ V, and 500 μ V. Scaling information is displayed as a vertical bar on the EEG wave together with its height equivalent in μ V.
 - When gridlines are switched on, scales are defined as a range, either ± 25 μ V, ± 50 μ V, ± 100 μ V, or ± 250 μ V. Scaling information is shown in the form of gridlines.

Switching BIS Filters On or Off

The low and high pass filters screen out undesirable interference from the raw EEG wave display. The notch filter removes line frequency interference. Filter settings affect the EEG wave and the SEF and TP values, but they do not affect the BIS, EMG, SR, and SQI values.

The filter settings are set in Configuration Mode. You can switch all the filters on or off together in Monitoring Mode.

- 1 In the **Setup BIS** menu, select **Filters**.
- 2 Select **On** or **Off** as required.

BIS Safety Information

For information on the use of BIS monitoring in specific monitoring situations and on pharmacological responses to the anesthetic agents Nitrous Oxide (when used as the sole anesthetic agent), Ketamine, and Etomidate, contact Medtronic to request a copy of their publication "A Clinician's Guide to the Bispectral Index".

Considerations for Use

Due to limited clinical experience in the following applications, BIS values should be interpreted cautiously in patients with known neurological disorders, those taking psychoactive medications, and in children below the age of 1.

WARNING

Conductive Parts: The conductive parts of sensors and connectors should not contact other conductive parts, including earth.

High-frequency Surgery: To reduce the hazard of burns in the high-frequency surgical neutral electrode connection, the BIS sensor should not be located between the surgical site and the electrosurgical unit return electrode.

Defibrillation: The BIS sensor must not be located between defibrillator pads when a defibrillator is used on a patient connected to the patient monitor.

Securing Cables: To minimize the risk of patient strangulation, the patient interface cable must be carefully placed and secured.

CAUTION

Revisions: The system will only function if all component revisions are compatible. Otherwise, an incompatibility INOP is displayed.

Impedance Checks: Impedance checks may influence data acquisition of other electroencephalographic devices.

Monitoring NMT

Neuro Muscular Transmission (NMT) and its measurement enables the evaluation of muscle relaxation of patients under Neuromuscular Block by measuring the strength of muscle reaction after electrically stimulating the dedicated motor nerve. The NMT Monitor electrodes are placed on the patients skin over the ulnar nerve, a controllable current source delivers stimulation pulses to two skin surface electrodes for the nerve stimulation, the muscle response is measured with an acceleration sensor.

WARNING

The NMT measurement may not be used for neonatal patients and is therefore not supported in the neonatal mode.

NMT stimulation current pulses may interfere with other sensitive equipment, for example, implanted cardiac pacemakers. Do not use the NMT measurement on patients with implanted medical devices unless so directed by a medical specialist.

Simultaneous use of the NMT with high frequency electrosurgical equipment may in unusual circumstances result in burns at the stimulation site and can also adversely affect measurement accuracy.

Do not use the NMT in close proximity to shortwave or microtherapy devices, there is a risk of adversely affecting the NMT measurement.

Explosion Hazard: Do not use in the presence of flammable anesthetics or gases, such as a flammable anesthetic mixture with air, oxygen or nitrous oxide. Use of the device in such an environment may present an explosion hazard.

Never apply the electrodes trans-thoracically (across the chest) or transcerebrally (across the head), there is a risk of seriously injuring the patient. Apply the stimulation electrodes close together as described in the Instructions for Use.

Never apply electrodes to patients in areas where inflammation or injury is evident.

When you are connecting the electrodes or the patient cable, make sure that the connectors **do not, and cannot,** come into contact with other conductive parts, or with earth.

Never touch the electrodes unless the stimulation has been stopped.

Patients with nerve damage or other neuromuscular problems may not respond properly to stimulation. The NMT measurement may show unusual patterns when monitoring muscle paralysis in these patients.

After repositioning the patient, check that the sensor is still applied and can move freely.

CAUTION

NMT monitoring is intended as an adjunct in patient assessment and must be used in conjunction with observation of clinical signs and symptoms.

NMT stimulation can be painful to a non-sedated patient. It is recommended not to stimulate before the patient is adequately sedated.

Use only electrodes suitable for nerve stimulation deemed appropriate by the attending physician. Pay special attention to current densities exceeding 2 mA r.m.s./cm² for any electrodes.

Stimulation Modes

The NMT module provides four stimulation modes:

- Train-Of-Four (**TOF**)
- Single Twitch (**Twitch**)
- Post-Tetanic Count (**PTC**)
- Double-Burst Stimulation (**DBS**)

Train-Of-Four (TOF)

In this mode four stimuli are applied every 500 milliseconds (2 Hz). Each stimulation of the train causes the muscle to contract. The fade in the individual response to each single stimulation provides a basis for evaluation. The NMT Module then calculates a TOF ratio (**TOFrat**) value in % using the ratio between the fourth and the first twitch. When fewer than four twitches are detected, the monitor displays a TOF count (**TOFcnt**) value instead, this represents the number of responses to the four TOF stimulation pulses.

Post-Tetanic Count (PTC)

The Post-Tetanic Count stimulation pattern starts with a sequence of four current pulses, delivered every 500 milliseconds (2 Hz). If a muscle response is detected, the PTC sequence is stopped and the responses are reported as TOF measurement. If there is no muscle response, the sequence continues with a five seconds long tetanic stimulation of current pulses delivered at 50 Hz, followed by a pause of 3 seconds, followed by 20 single current pulses delivered every second (1 Hz). Muscle response detection is active only during the first 4 single pulses and the last 20 single pulses. During the last 20 pulses, the **PTC** value is incremented with each detected muscle response.

Single Twitch (Twitch)

If this mode is configured the NMT Module measures the response to single electrical stimuli applied to peripheral motor nerves. The module sends a single pulse and measures the strength of the resulting twitch, the module then calculates a Twitch Ratio (**Twitch**) value in %. If the displayed numeric is 80, the strength of the measured twitch was 80% of that of the reference twitch, see [“Calibrating the NMT Measurement” on page 326](#).

Double-Burst Stimulation (DBS)

The Double-Burst stimulation pattern consists of a sequence of 3 current pulses delivered every 20 milliseconds (50 Hz), followed by a pause of 750 milliseconds, followed by another sequence of 3 current pulses delivered every 20 milliseconds (50 Hz). With each detected muscle response the DBS Count (**DBScnt**) value is incremented.

Preparing to Measure NMT

The IntelliVue NMT Module is intended to be used only with adult and pediatric patients.

Skin Preparation for Electrode Placement

Good electrode-to-skin contact is important for a good stimulation pulse. Insufficient cleaning of the skin can cause high skin resistance which could cause the stimulation to stop.

- 1 Select sites with intact skin, without impairment of any kind.
- 2 Clip or shave hair from sites as necessary.
- 3 Wash sites thoroughly with soap and water, leaving no soap residue.
Do not use ether or pure alcohol as this dries the skin and increases the resistance.
- 4 Dry the skin thoroughly.

Placing the NMT Electrodes and Transducer

Stimulation of the ulnar nerve in the wrist is preferred for routine monitoring.

CAUTION

To avoid unintentional electrical shocks always make sure that the NMT stimulation has been stopped before touching the electrodes.

NOTE

Ensure that the thumb can move freely before applying the NMT sensor.

Place the electrodes on the prepared site over the ulnar nerve on the palmar side of the wrist; refer to the figure below.

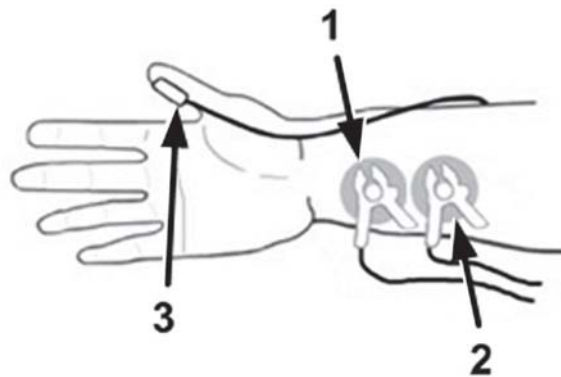

- 1 Black cable clamp
- 2 Red cable clamp
- 3 Transducer

- 1 Place the distal electrode near the wrist.
- 2 Place the proximal electrode 2 to 3 cm proximal to the distal electrode.
- 3 Attach the Black cable clamp to the distal electrode, (see figure above).
- 4 Attach the Red cable clamp to the proximal electrode, (see figure above).
- 5 Secure both cables on the arm so that no tension is applied to the clamps. Tension could increase the electrode resistance and place strain on the cables.
- 6 Place and affix the transducer with a large flat side against the palmar side of the thumb. Secure the cable so that it does not 'pull' at the transducer and that movement of the thumb is not obstructed. The more distal the transducer is placed on the thumb, the stronger the acceleration signal.

CAUTION

Make sure that the lead wires cannot come into contact with external pacemaker or catheter wires.

Arm Position

The arm used for the NMT measurement, should be kept immobile during the whole procedure.

Taking NMT Measurements**NOTE**

Both the NMT calibration and NMT measurement cannot be started:

- When the parameter (NMT) is switched off
- During the recovery phase after a measurement.
- During an ongoing automatic measurement cycle.
- During an ongoing calibration
- When error conditions have been detected.
- When no patient cable is connected.

Calibrating the NMT Measurement

With the NMT calibration the supramaximal stimulation current is determined and the reference twitch is set to 100%. The reference twitch is the twitch at the supramaximal stimulation current when the patient is not paralyzed. This must be done prior to administration of Neuromuscular Blocking Agents (NMBA).

If the NMT Module is unable to establish a reference twitch, it uses an internal reference value for single-twitch measurements.

NOTE

It is recommended that the patient be anesthetized before setting up the calibration twitch as nerve stimulation can be painful.

Starting Calibration

For three seconds before starting the calibration, and during the calibration, the hand with the sensor must be kept still.

- 1 Either press the NMT key on the module, or select the numeric on the screen to enter the **Setup NMT** window.
- 2 Select **Start Cal.**
- 3 Select **Confirm.**

This automatically determines the supramaximal stimulation current and takes the reference twitch (100%) at this current. If the NMT Module is unable to establish a reference twitch, it uses an internal reference value for single-mode measurements.

Clearing a Reference Twitch

Clearing the Reference Twitch resets the supramaximal stimulation current and reference twitch to default values. To clear the stored references:

In the **Setup NMT** window:

- 1 Select **Clear Reference**.
- 2 Select the **Confirm** key to reset the stored supramaximal stimulation current and reference twitch to the default values.

NOTE

- This function is not available if a calibration is in progress or no calibration data is stored.
- The reference twitch and supramaximal stimulation current are not cleared automatically with **Discharge Patient** or **End Case**.

CAUTION

Changing the stimulation current or pulse width also clears stored references.

Starting/Stopping NMT Measurements

To Start NMT measurements, in the **Setup NMT** window select the start key for the mode used, (for example, **Start TOF**).

If you need to change the NMT settings after startup, stop the measurements, change the settings, then restart the measurements.

To Stop NMT measurements, in the **Setup NMT** window select **Stop**, the measurement is immediately interrupted.

If Automatic Start is configured and Auto Mode is selected, the automatic measurement cycle will start immediately after a successful calibration. See your Configuration Guide for details.

NOTE

To stop NMT stimulation in an emergency, disconnect the NMT patient cable from the NMT Module.

During an automatic measurement cycle the yellow Start/Stop LED on the NMT Module is lit. If the automatic cycle is stopped, or the measurement mode is set to manual the LED is off.

The LED flashes (in both modes) when a stimulation pulse is given.

CAUTION

To avoid unwanted electrical shocks **DO NOT** touch the electrodes when the yellow Start/Stop LED is flashing on the NMT module.

NOTE

Take care when removing the transducer from the patient. Do not pull on the cable.

Changing the NMT Measurement Settings

Selecting the NMT Stimulation Mode

In the **Setup NMT** window:

- 1 Select **Stimulation** to enter the Stimulation window.
- 2 Choose the Stimulation mode required:
 - **TOF**
 - **PTC**
 - **Twitch** (if configured)
 - **DBS** (if configured)

Measurement Mode

Allows the choice between manual and automatic NMT measurements.

In the **Setup NMT** window:

- 1 Select **Mode** to open the Mode window.
- 2 Select **Auto** or **Manual** mode.

NOTE

Auto mode is not available if the **PTC** or **DBS** stimulation mode is selected.

Selecting the Repeat Time (only available in Auto mode)

Repeat Time allows you to select the time intervals between automatic NMT measurements.

NOTE

This function is not available in the **PTC** and **DBS** mode.

In the **Setup NMT** window:

- 1 Select **Repeat Time** to open the Repeat Time window.
- 2 Select the required setting.

Selecting the Stimulation Current

To set the stimulation current, in the **Setup NMT** window:

- 1 Select **Current** to open the Current window.
- 2 Select the required setting.
- 3 If you are modifying a previously calibrated current, select **Confirm**.

CAUTION

Changing the stimulation current after calibration invalidates the stored reference data.

Selecting the Pulse Width

Setting a Pulse Width sets the duration of the stimulation pulse.

In the **Setup NMT** window:

- 1 Click on **Pulse Width** to open the Pulse Width window.
- 2 Select the required setting.
- 3 Select **Confirm** if you wish to modify a previously calibrated pulse width.

CAUTION

Changing the stimulation pulse after calibration invalidates the stored reference data.

Value Lifetime

Displays the time after which an NMT numeric value disappears from the resting display.

The **Value Lifetime** setting is visible (grayed out) in the **Setup NMT** window. The setting can only be changed in the Configuration Mode.

NMT Tone Volume

Enters a list of selections to adjust the audio volume of the NMT stimulation tone. If not zero, each NMT stimulation pulse is indicated by a short beep.

You can change the **NMT Tone Volume** in the **Setup NMT** window.

Alarms

TOFcnt High Limit Alarm

In the **Setup NMT** window:

- 1 Select the **TOFcnt High Lim.**
- 2 Select limit: 0, 1, 2, 3.

NMT Alarm Suppress

Depending upon your configuration, the **TOFcnt** high alarm maybe suppressed until the **TOFcnt** value has reached 0 for the first time. This setting can only be changed in the Configuration Mode.

Understanding NMT Numerics

Numerics

TOF ratio (**TOFrat**), TOF count (**TOFcnt**), Twitch ratio (**Twitch**) and DBS Count (**DBScnt**) numerics show the result of an NMT measurement. Together with these numerics either the time the measurement was taken or the time until the next measurement is shown. The extended numeric representation shown will only be available when using a screen designed to show it. The relative strength of individual muscle responses, as measured by the acceleration sensor are displayed as a bar graph.

Dependent upon the selected stimulation mode the following information is provided:

Stimulation Mode	Numeric Label	Unit	Trend	Number of Bars
Single-Twitch	Twitch	%	None	1
Train-Of-Four	TOFrat	%	Yes ¹	4
	TOFcnt		Yes ¹	4
Post-Tetanic-Count	PTC		Yes	1...20
Double-Burst	DBScnt		None	2

¹ In Auto mode, a maximum of one value per minute is stored in the trend.

Auto Mode

The figure below shows the NMT measurement in **Auto** mode.

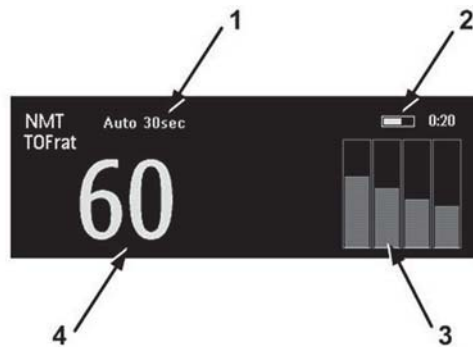

- 1 NMT: **Auto** mode, **Repeat Time** 30 sec.
- 2 Time until next measurement or the time the measurement was taken.
- 3 Bar graph showing relative strength of each twitch. If a calibration has been made, the strength of the calibration reference twitch is shown as a white line.
- 4 **TOFrat** expressed as %.

Manual Mode

The figure below shows the NMT measurement in **Manual** mode.



- 1 NMT: **Manual** mode, (there is no **Repeat Time**).
- 2 Time the measurement was taken (**Timestamp**).

Recovery Time

Most NMT stimulation modes require a minimum neurophysiological recovery time and during this recovery phase no new stimulation can be started. Also, you cannot start a measurement or calibration.

Guardian Early Warning Scoring

With a monitor with the appropriate option, you can use Guardian Early Warning Scoring to get an early warning score based on vital signs and clinical observations collected at intervals.

The goal of an early warning score is to help you recognize the early signs of deterioration in patients. Depending on the score calculated, recommended responses are displayed. There are no dedicated alarms associated with an early warning score (EWS).

WARNING

When using Guardian Early Warning Scoring, request a printout of the EWS scoring table and the recommended response lists from your configuration expert. Use them to verify that the configuration of the scoring functionality matches your hospital's requirements.

The Information Center can pass the entered data and the early warning scores on to other connected systems. The presentation and handling of the information at the Information Center depends on its software version and configuration. Refer to your PIC iX Instructions for Use for details.

Understanding Guardian Early Warning Scoring

An early warning score is an assessment aid used to help recognize the early signs of deterioration in medical patients and trigger an appropriate response. When the score reaches a predefined threshold, this triggers the recommendation of responses ranging from making more frequent assessments to calling a rapid response team. There are various types of scoring systems in use in healthcare institutions. A basic scoring system will often have variations that have been modified to reflect the needs of specific patient groups.

There are two basic types of scoring:

Single parameter scoring (e.g. SPS) - A score is given for each of the vitals or clinical observations based on the value measured or entered. Depending on the risk level associated with the score, a response may be recommended. If several parameters have scores requiring a response, all the responses will be listed.

Multiparameter scoring (e.g. MEWS, PEWS) - A subscore is given for each of the vitals or clinical observations based on the value measured or entered. When all the required vital signs and clinical observations have been entered or measured, the subscores are added together to give the total score. This type of scoring system is called an aggregated scoring system. Sometimes the parameters are grouped together (e.g. Respiratory, Cardiovascular) and the maximum subscore from the group contributes to the total score. Each subscore can have a color coding, to indicate the level of risk associated with it. The total score can also have color coding and a risk level, that determines the response that is recommended.

EWS on the Monitor



For early warning scoring on the monitor, a very flexible configuration program can be used to recreate electronically an existing paper-based assessment method. When your system was set up, one or more scoring protocols were configured. For each of these protocols many configuration decisions were made, including:

- Which vital signs, clinical observations, lab data and demographic data (age, weight, etc.) are needed for scoring
- Which responses are recommended for specific scores or risk bands
- How the data is displayed in the entry window
- How scores are displayed on the monitor
- How long measured or entered data remains valid
- How subscores are combined in multi-parameter scoring models

Due to this flexibility it is not possible to show a system here that corresponds exactly to the one you are using. Where necessary, typical examples are used when showing how to interact with the system.

Performing the Scoring Procedure

- 1 To run Guardian Early Warning Scoring (EWS) you need to switch to a Screen with an embedded EWS window.
 - a. Select the current Screen name in the monitor info line.
 - b. Select your EWS Screen from the list.
 Or select the **EWS/SpotChk** SmartKey, if configured.
- 2 Check that the correct scoring protocol for this patient is shown at the top left of the EWS window. If not, change the protocol:
 - a. Select the protocol name on the screen.
 - b. Select the correct scoring protocol from the list.
- 3 Start collecting vital signs and entering observations. If the patient is continuously monitored, any relevant vitals currently being measured will appear automatically in the EWS window. Similarly any required lab data or demographic data that is available on the monitor will be entered automatically. Other vitals may be measured on request by the monitor, or may need to be entered manually. All boxes with a light gray background require action from you:

- All vital signs or clinical observations **without** a keypad symbol  have only one way to enter data. Select the box to either start a measurement or open an entry window. If an entry window opens, select an observation from the list or enter the required data with the keypad and select **Enter**.
- Any vital signs **with** a keypad symbol  have two alternative ways to enter data. Select the box itself to start a measurement or select the keypad symbol to enter data manually.

All data boxes with a light gray background are **required**; they must all be filled for a complete SpotCheck record. All other data boxes are for optional data. When you have entered or measured data, the light gray background changes to dark gray.



- One complete set of vitals and observations, together with the calculated score(s), is referred to as a SpotCheck record. Once all the required vitals and observations have been entered or measured, the SpotCheck record will be automatically stored after the configured procedure time (unless configured not to save). Until the end of the procedure time, the background of the window is light gray, to indicate that the data has not yet been stored.

If you want to store values manually before the end of the procedure time, you can select **Store VS**, to store the values and close data collection. The **Store VS** key can also be used to store an incomplete set of vitals at any time.

Depending on your configuration, the EWS trend data may be automatically displayed after a record has been stored.

If you want to break off the Early Warning Scoring procedure without storing the SpotCheck record, use the **Clear VS** key.

- To leave the EWS procedure and return to your standard monitoring screen, select the appropriate screen from the screen list, or select the **Previous Screen** SmartKey (if configured).

WARNING

Alarms: There will be no alarm indications for measurements in the EWS window.

Values: The values shown in the EWS window do not have the same annotation as the measurement values on other monitor screens. There is no special indication when a value has been manually entered and no timestamp showing when the value was measured/entered. Be aware that values will remain visible until the procedure time is at an end, even when the measurement itself is no longer providing current values.

Triggering Scoring Automatically

During continuous monitoring, early warning score data can be generated automatically, triggered by one or more of the following:

- a specific intermittent measurement (SpO₂, NBP, or cmRR)
- a patient alarm
- a schedule

During a one-minute interval after the trigger, the monitor collects all available measurements that are required for the current protocol. Depending on the protocol in use, the measurements and observations are assigned a score or a subscore and the record is saved.

Note that observations and measurements from a previous manual procedure may also be included. This is the case if they are still valid according to the configured measurement lifetime.

Setting Up Automatic Scoring

To set up automatically triggered scoring, select **Main Setup**, then **SpotCheck**, followed by **Automatic VS**.

- 1 Select **Interval** to enable the scheduled generation of scoring data.
- 2 Select **Interval time** to specify the interval for the schedule trigger.
- 3 Select **Patient Alarm** to enable triggering on patient alarms.
- 4 Select **SpO₂** to enable triggering on an SpO₂ measurement (using the CL SpO₂ Pod).
- 5 Select **NBP** to enable triggering on an NBP measurement.
- 6 Select **cmRR** to enable triggering on a cmRR measurement.

Viewing EWS Trend Data

Stored SpotCheck records are presented as a trend in the monitor. The database for the SpotCheck trend is separate from the one for the standard monitor trends.





To view trend data, select the **SpotChk Trend** SmartKey. A tabular trend will be shown, with all measured and entered data and any calculated scores and subscores. The data columns are arranged according to the level of importance. You can use the up arrow and down arrow keys to scroll through the list of SpotCheck records.

Date	Time	EWS	HR/Pis	SpO ₂	BP	Temp
-	-	∇	● 60	● 95	-/- (-)	-
9 Dec	16:34	10	● 60	● 95	● 222/111 (148)	● 41.0
9 Dec	16:33	◇	● 60	● 95	-/- (-)	-
9 Dec	16:33	5	● 60	● 95	● 165/110 (128)	● 38.3
9 Dec	16:32	7	● 60	● 95	● 155/99 (118)	● 38.3

- 1 This symbol indicates that more information is available than can be shown on the Screen. Use the paging keys << and >> to page back and forwards in the available data.

Symbols Used in the Trend Views

The following symbols can appear in the trend views:

Symbol	Indicates
	SPS SpotCheck record - color depends on the risk level
	EWS score - color depends on the risk level
	Manual SpotCheck record
	Automatic SpotCheck record
	Record triggered by a patient alarm

Making Recordings

The trend data can be sent to a recorder using the recording pop-up keys.

	In single patient views	In multiple patient views
Record Selected	Makes a recording for the selected SpotCheck record.	Makes a recording for the selected SpotCheck record.
Record 8 h	Makes a recording of the last 8 hours of data for this patient.	Makes a recording of the most recent SpotCheck record for all patients within the last 8 hours.
Record All	Makes a recording of all available SpotCheck records for this patient.	Makes a recording of the most recent SpotCheck record for all patients.

At the beginning of the recording, the title, the type of recording and the time will be printed. If available, the patient's name, date of birth, ID and the type of scoring (protocol name) currently active will also be printed. The data from the SpotCheck record is printed in columns.

As the SpotCheck trends are in a separate database, you can only print data via the recording keys described above and not via the standard monitor trend or patient report functions.

Using a Telemetry Device and a Monitor (PIIC only)

It is possible to assign a monitor and a telemetry device to the same patient, resulting in the information from both devices being combined in one sector at the Information Center. This is called "pairing" and when a telemetry device and a monitor are paired, the measurement data from the telemetry device will be displayed on the monitor screen.

A telemetry device can be:

- any Philips telemetry device (only for indirect connections, see below).
- a TRx/TRx+ IntelliVue Telemetry system transceiver.
- an X2 or X3 Multi measurement module with a telemetry interface, declared as a telemetry device and with a telemetry equipment label.

For complete user information, including accessory listings and specifications, for the M4841A/M4851A TRx/TRx+ IntelliVue Telemetry Transceiver, refer to the Instructions for Use provided with the device.

How Can You Combine Devices?

- With an **indirect** connection, using standard telemetry transmission: The data are sent to the monitor via the Information Center and arrive with a delay of several seconds at the monitor.
- With a **direct** connection to the monitor,
 - an X2/X3 is connected via MSL cable to the monitor, **or**
 - a telemetry transceiver with a short range radio adapter is assigned to an X2 which is connected (Companion Mode) to an MX750/MX850 host monitor,
 the data arrive with a minimal delay on the monitor screen.

Indirect Connection - Manual Pairing

The telemetry device can be paired with the monitor at the Information Center or at the monitor. For detailed information regarding pairing and configuration at the Information Center, see the Information Center Instructions for Use.

To pair the monitor with a telemetry device at the monitor:

- 1 Select **Main Setup** then **Measurements**
- 2 Select **Telemetry**
The **Setup Telemetry** menu will appear with only one entry **Paired Equipment**.
- 3 Enter here the equipment label of the telemetry device to be paired.

Pairing at the monitor is only possible when the monitor already has a connection to the Information Center and the Information Center software version allows pairing at the monitor.

Own Patient Overview Window

The measurements from the telemetry device are shown in the own patient overview window on the monitor. See .

Direct Connection - Automatic Pairing

The following direct connections are possible:

- an X2 or X3, declared as a telemetry device, and connected with an MSL cable to a monitor.

WARNING

- When ECG is being measured with a telemetry device directly connected to the monitor, there will be no ECG signal available at the ECG analog output or ECG Sync Pulse output and no synchronization marks on the ECG wave. A **No ECG Out** message will appear in the ECG wave channel.
 - When a telemetry device is connected to the monitor, arrhythmia relearning is initiated, and again when the telemetry device is disconnected.
 - Controls on the Telemetry Device (e.g. nurse call) will be inactive when the device is directly connected to the monitor except in the case when the monitor has no network connection and data are transferred via the telemetry device.
-

Pairing an X2/X3 With a Telemetry Interface to a Host Monitor

An X2 or X3 Multi-Measurement module using an IntelliVue Instrument Telemetry interface will be automatically paired when it is connected to a host monitor and it has been declared as a "telemetry device" at the Information Center.

When the X2/X3 is disconnected from the host monitor it will remain paired and the measurement data will appear at the host monitor in the Telemetry Data window. After the X2/X3 is disconnected from the monitor it may take over 15 seconds until their data is displayed at the Information Center.

Pairing of a host monitor and a telemetry device, with all the related functionality, is only possible when the **host monitor** is using a wired LAN connection or a wireless LAN interface (but not using the IntelliVue Instrument Telemetry interface).

The X2/X3 can also be manually paired to a host monitor without a direct connection, as described in [“Indirect Connection - Manual Pairing”](#) on page 337.

Refer also to [“Use Models With Telemetry”](#) on page 339 for further related use modes.

Unpairing the Monitor and Telemetry Device

If the patient will no longer be monitored with the telemetry device, or only with the telemetry device and no longer with the monitor, you need to end the device pairing. After unpairing, the Information Center will receive data exclusively from the monitor or from the telemetry device:

- select the **Unpair To Mon.** SmartKey to end pairing and have the Information Center receive the measurement data from the monitor



- select the **Unpair To Tele** SmartKey to end pairing and have the Information Center receive the measurement data from the telemetry device



or use the Unpair function at the Information Center.

NOTE

The SmartKeys and pop-up keys for unpairing appear only on the monitor which is directly involved in pairing.

Use Models With Telemetry

The standard use model combining a monitor and a telemetry device involves pairing the two devices so that the data measured by the telemetry device appears on the monitor screen - and at the Information Center in the same patient sector as the monitor data. The following variations are possible:

- 1 The monitor is paired with a telemetry transceiver - indirect connection
 - telemetry data appear on the monitor
- 2 An X2 or X3 is declared as a telemetry device and paired with an MX750/MX850 monitor - direct or indirect connection
 - X2/X3 measurement data appear on the monitor it is paired with
 - a telemetry transceiver cannot be used with the X2/X3
- 3 A telemetry transceiver directly connected via SRR to an X2, that is connected (via Companion Mode) to an MX750/MX850 monitor - direct connection
 - telemetry data appear on the **host monitor**
 - telemetry transceiver is paired with the host monitor but is assigned to the X2
 - **the X2 must have no equipment label**

The different variations require different configuration settings; refer to the Configuration Guide for details.

Trends

Trends are patient data collected over time and displayed in graphic, tabular or histogram form to give you a picture of how your patient's condition is developing. Trend information is stored in the trends database for continuously-monitored measurements, such as ECG, as well as for aperiodically-measured parameters, such as noninvasive blood pressure.

Viewing Trends

Trend information can be viewed embedded as a screen element on specially-designed Screens, or you can open a trend window over the current Screen.

- To view trends embedded as a screen element, enter the **Change Screen** window, then select a Screen designed to show an embedded trend window.
- To open the tabular trends window over the current Screen, select **Main Setup, Trends**, then **Vitals**

Trend, or select the **Vitals Trend** SmartKey



- To open the graphic trends window over the current Screen, select the **Graph Trend** SmartKey



- To open the histogram trend window over the current screen, select **Main Setup, Trends**, then **Histogram**, or select the **Histo-gram** SmartKey.



The trend windows open displaying the most recent data and are updated as new data is stored. A timescale along the bottom or the top of the screen shows you where you are in the trends database. The preview column on the right-hand side shows the latest available measurement value. The preview column is updated every five minutes or whenever an NBP or other aperiodic measurement is completed.

A question mark (?) beside a value means that the data may not be reliable, due perhaps to an INOP condition in the measurement.

Your monitor screen may look slightly different to the examples shown in this chapter.

Trends Pop-Up Keys

When you open the graphic, tabular or histogram trends window, a selection of pop-up keys appears to let you navigate through the stored trend data and carry out trends-related tasks.

Pop-Up Keys	Selecting this pop-up key lets you....
Select Group	see a pop-up list of trend groups and select a group for viewing.
Select Interval	see a pop-up list of available data resolution settings and select the level of detail shown in the trend view.
Print/ Record	print a tabular trends report or make a tabular trend recording of the data in the current window. The report will use the current trend interval settings.
Print	print a graphic trends report or histogram report of the data in the current window. The report will use the current trend interval settings.
◀▶	move the cursor one step to the left or right to navigate through the trends database timeline.
◀▶▶	move the cursor one page to the left or right to navigate through the trends database timeline.
◀▶▶▶	jump to the beginning or the end of the trends database to see the most recent or oldest trend information stored.
▲▼	scroll up and down the screen to see measurement trends that do not fit in the current view.
Vital Signs	open the current trend view in tabular form. The displayed time period and resolution stay the same.
Graph Trend	open the current trend view in graphic form. The displayed time period and resolution stay the same.
Data Source	select a realtime SpO ₂ or realtime system pulse or trended data for display in the histogram.
Period	select a time period for the histogram.
Select Range	define the range of values to be displayed in the histogram by selecting an upper and a lower limit.
Column	select a column width for the histogram. For each width selection the resulting number of columns is shown.
Curve On/Off	switch the display of the cumulative value columns in the histogram on or off.
Adjust Cursor	open a new set of pop-up keys for switching on cursors and setting their positions.

Viewing Graphic Trends

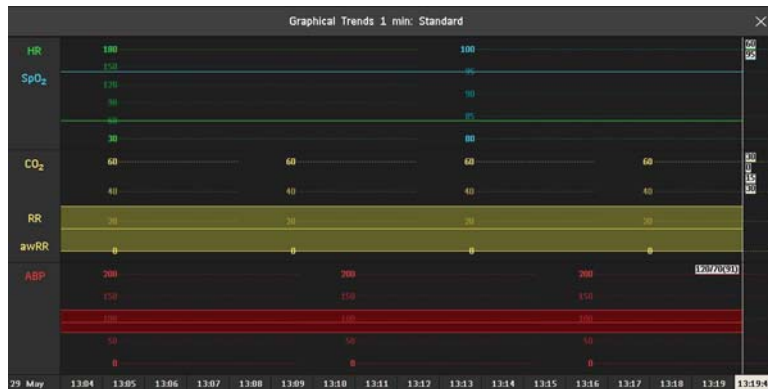

A cursor spanning all measurements in the trend group helps you to navigate through the trends database and shows you your current position in the database. When the cursor is moved across the time line, the values measured at the cursor time are shown in the right hand column.

In graphical trends, aperiodic measurement trends are shown as an asterisk, NBP has a special symbol.

To use the trend cursor to navigate in time through the trends database,

- 1 Select the graphical trend or the arrow pop-up keys to activate the cursor.
- 2 Use the arrow pop-up keys to move the trend cursor backwards and forwards in time, or
- 3 Place the cursor at a specific time by touching the graph.

Viewing Vital Signs Trends

Vital Signs 1 min: Standard										
HR	60	60	60	60	60	60	60	60	60	60
SpO ₂	95	95	95	95	95	95	95	95	95	95
NBP _s	---	---	---	---	---	---	---	---	---	120
NBP _d	---	---	---	---	---	---	---	---	---	80
NBP _m	---	---	---	---	---	---	---	---	---	90
										15:37
etCO ₂	30	30	30	30	30	30	30	30	30	30
ImCO ₂	0	0	0	0	0	0	0	0	0	0
RR	---	---	---	---	---	---	---	---	---	15
awRR	30	30	30	30	30	30	30	30	30	30
ABP _s	120	120	120	120	120	120	120	120	120	120
ABP _d	70	70	70	70	70	70	70	70	70	70
ABP _m	91	91	91	91	91	91	91	91	91	91
PAP _s	28	28	28	28	28	28	28	28	28	28
PAP _d	15	15	15	15	15	15	15	15	15	15
PAP _m	21	21	21	21	21	21	21	21	21	21
16 Apr	15:29	15:30	15:31	15:32	15:33	15:34	15:35	15:36	15:37	15:38

- 1 Aperiodic values are shown with a timestamp

The currently-selected column is highlighted. The values can be configured to display in the same colors as the waves and numerics on the realtime display.

Any values available for display before the next scheduled update are shown in the right hand column, with a timestamp in brackets.

If more than one value is available for an aperiodic trend for a certain trend period, all measured values are stored in the database and the value closest to the timestamp is shown in the Vital Signs display marked with an arrow.

To view the Vital Signs trend with one column for each NBP measurement (see “[Defining the Column Interval Using the NBP Measurement](#)” on page 347):

- 1 With the Vital Signs trend open, select **Interval**.
- 2 Select **NBP** from the pop-up list.

Viewing Histogram Trends

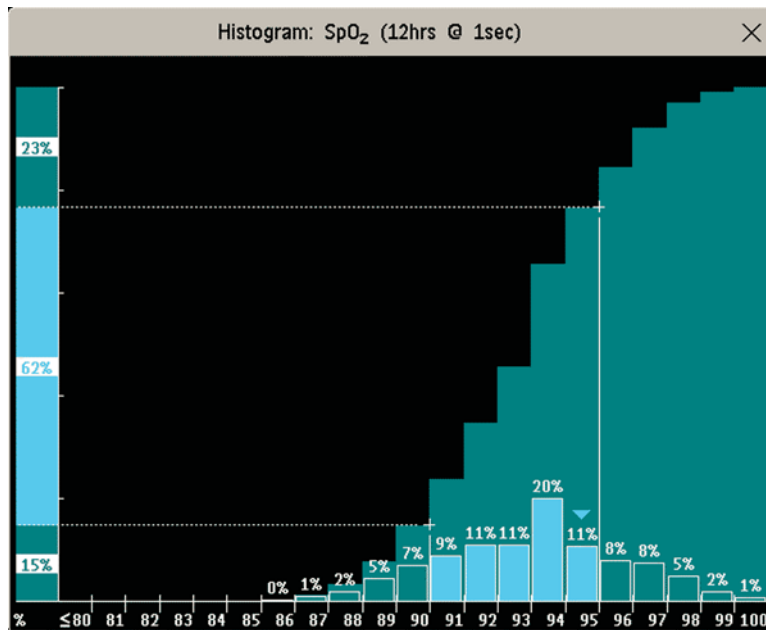

The title line of the window shows the label of the trended measurement and the resolution of the data; in the SpO₂ histogram above, 1 second realtime samples.

The horizontal axis shows the range and unit of the displayed measurement. The vertical axis shows the percentage of time.

The columns in the foreground show how much of the time the measured values fell into this range on the scale. For example, in the histogram above, the SpO₂ value was between 93 and 94% during 20% of the last 12 hours. The display of the percentage value above each column, can be switched on or off by selecting the histogram. The arrow mark over a column shows that the currently measured value is also in this range. The columns are displayed in the same color as the measurement data.

The columns in the background show the cumulative percentage value: each of the foreground columns is added to the sum of those columns to the left of it. The cumulative columns can be switched off using the **Curve On/Off** pop-up key.

A question mark is displayed if less than two-thirds of the data are valid samples.

The pop-up keys in the window can be used to change the measurement, the time period and the range. You can also print out a histogram report.

The SpO₂ and System Pulse histograms can use trended data or realtime data with 1 second samples.

Using Cursors

You can set two cursors that span a "corridor", for example to divide a histogram into in-range and out-of-range areas. Or you can set both cursors to the same value and use them as one cursor to divide the histogram into an upper and a lower segment. The cursors are represented by a vertical line from the x-axis and a dotted horizontal line from the y-axis. When two cursors are used, they can be locked using **Lock/Unlock**, so that the distance between them is fixed. Moving a cursor will then move both together. Select **Lock/Unlock** again to separate the cursors and move them independently again.

A summary column on the y-axis shows the lower, middle and upper ranges as determined by the cursor positions. When only one cursor is used there will be a lower and an upper range. Color shading is used to differentiate the ranges in the cumulative column and to highlight the columns between the cursors.

Setting Up Trends

Trends are set up in Configuration Mode. You can make temporary changes to trends settings such as trend groups, priorities, or scales in Monitoring Mode. The general settings for all Trends are under **Main Setup, Trends**.

Settings for a single segment in graphical trends or for the corresponding trend group can be made more easily in that segment menu.

Making Segment Settings

The **Graphical Trends** window is divided into measurement segments, each of which has its own settings.

To enter the segment menu,

- select the left hand column of the segment, where the measurement label is displayed.

Expanded View

To expand the segment to fill the **Graphical Trends** window,

- in the **Segment** menu, select **Expand** to have that segment enlarged to fill the window.

In the expanded view, you can also highlight a measurement to make it more easily visible (for example when multiple ST trends are in one segment). To highlight a measurement,

- in the **Segment** menu, select **Highlight** repeatedly until the highlight is on the required measurement.

To return the segment to its original size,

- in the **Segment** menu, select **Expand** again.

Trend Scales for Segment Measurements

To change the trend scales for a measurement in the current segment:

- 1 In the **Segment** menu, select the measurement label.
- 2 Select **Upper** to change the upper limit of the scale or **Lower** to change the lower limit of the scale.

Optimum Scale

To have the monitor automatically select an optimum scale for viewing, based on current values,

- in the **Segment** menu, select **Optimum Scale**.

This scale change is temporary. When the graphical trend window is closed the scale reverts back to the setting in **Parameter Scales**.

To switch off automatic optimum scaling,

- in the **Segment** menu, select **Optimum Scale** again.

Trend Group

To add or remove measurements for this trend group or change the order of the existing measurements:

- 1 In the **Segment** menu, select **Change Group**.
- 2 Use the **Add, Change, Sort Up** and **Sort Down** pop-up keys to change or re-order the group as required.

Number of Segments

In an embedded graphical trend window, you can select the number of segments to be displayed in the **Segment** menu:

- In the **Segment** menu, select **No. of Segments**.

Trend Groups

The measurements grouped in trend groups define the trends displayed together in the **Vital Signs** or **Graphical Trends** windows and printed in trends reports and recordings. The sequence of the measurements in the group defines the order in which they are displayed. Measurements listed between dotted line separators are displayed overlapping. The trend group **All** contains all available measurements, you cannot change the order or selection of this group.

To change the selection of measurements in a trend group, either use the **Change Group** setting in the **Segment** menu or:

- 1 Select **Main Setup, Trends**, then **Trend Groups**.
- 2 Select the Trend Group you want to change and use the pop-up keys to **Add, Change, or Delete** the selection of measurements trended.

To temporarily change the order in which the measurements are displayed in a group,

- 1 Select **Main Setup, Trends**, then **Trend Groups**.
- 2 Select the Trend Group and then the measurement you want to move and use the **Sort Up/Sort Down** pop-up keys.

Trend Interval

The trend interval defines the resolution of trend data shown on the Screen. High-resolution data is especially suited for neonatal applications, where the clinical situation may change very quickly. In adult monitoring, where the patient's status typically changes more gradually, a longer trend may be more informative.

To set the trend resolution, in the **Vital Signs** or **Graphical Trends** window,

- Select the **Select Interval** pop-up key and then select the required interval from the list.

Trend Priority

The monitor stores trend information for all monitored measurements, if configured to do so. (Data from IntelliBridge modules cannot be included in trends when the label is a free-text label.) If your configuration restricts the number of measurements trended, you must choose which measurements will be included. A priority list is used to select the trended measurements.

To see the measurement priority list for trending,

- 1 In the **Main Setup** menu, select **Trends**.
- 2 Select **Trend Priority**.

To add measurements to the priority list,

- 1 Select the pop-up key **Add** and choose from the pop-up list of available measurements.
- 2 Use the **Sort Up** and **Sort Down** pop-up keys to change the priority order.

Trend Parameter Scales

Parameter scales define how the trend waveform will appear on the screen and in trend reports. Separate scales can be set for adult, pediatric, and neonatal patient trends.

To change the trend parameter scales settings, either use the **Scale** setting in the **Segment** menu or:

- 1 In the **Main Setup** menu, select **Trends**.
- 2 Select **Parameter Scales**.
- 3 Select the measurement or parameter you want to change from the list.
- 4 Select the pop-up key **Change** to call up the **Scale** menu.
- 5 In the **Scale** menu, select the parameter label you want to define settings for. Select **Adult, Pedi, and Neo** and use the pop-up keypad to enter new upper and lower scale definitions.

Graphical Trend Presentation

Graphical trends and screen trends for measurements with compound values (for example ABP or CO₂) can be viewed in line or band form.

To change the presentation style,

- 1 Select **Main Setup** then select **Trends**.
- 2 Select **Global Style** and choose
 - **Line** to display the trends as a continuous line
 - **Band** to fill the area between the trend lines, for example, between the systolic and diastolic pressures, with color.

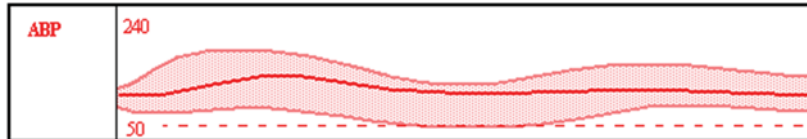

This sample ABP trend shows the continuously-measured values for the systolic, diastolic and mean pressures displayed in band form.

Defining the Column Interval Using the NBP Measurement

You can have the NBP measurement determine the interval between the columns on the Vital Signs trend. Each NBP measurement will generate a column in the trend table. The values for the other measurements are added to the column to provide a complete vital signs set for the NBP measurement time.

To use the NBP measurement to determine the column interval:

- 1 Select **Main Setup** then **Trends**.
- 2 In the **Trends** menu, select **Setup VitalSigns**.
- 3 In the **Vital Signs** menu, select **Column** and then **NBP** from the pop-up menu.

Making Settings for Histograms

To make settings for histograms, first display the **Trends** window by selecting **Main Setup** then **Trends**.

Setting the Default Measurement

To set the default for the measurement data to be used in the histogram, in the **Trends** window,

- 1 Select **Setup Histogram**.
- 2 Select **Data Source**.
- 3 Select either
 - **Realtime Data**, and then a realtime SpO₂ or Pulse, or
 - **Trended Data** and then select the required measurement from the trended data list.

Setting the Default Period

To set the default period for the histogram, in the **Trends** window,

- 1 Select **Setup Histogram**.
- 2 Select **Select Period** and select the required time period from the list.

Setting the Unit for the Data Source

To set the unit for the selected measurement data source, in the **Trends** window,

- 1 Select **Setup Histogram**.
- 2 Select **Unit** and select a unit from the list.

Switching Cumulative Value Columns On and Off

To switch the display of the cumulative value columns on or off, in the **Trends** window,

- 1 Select **Setup Histogram**.
- 2 Select **Curve On/Off**.

Setting the Range for the Measurement

To set the range to be displayed on the x-axis, in the **Trends** window,

- 1 Select **Setup Histogram**.
- 2 Select **Range**, then enter a value for the lower end of the range and the upper end of the range.

Displaying Percentages on Columns

To switch the display of the percentage values above the columns on or off, in the **Trends** window,

- 1 Select **Setup Histogram**.
- 2 Select **Column Value**.

Switching the Cursor On and Off

To switch the cursor and the summary column on or off, in the **Trends** window,

- 1 Select **Setup Histogram**.
- 2 Select **Cursor**.

Setting Initial Cursor Positions

To set the positions of the cursors, in the **Trends** window,

- 1 Select **Setup Histogram**
- 2 Select **Cursor Range** then enter a value for the upper and lower cursors. If both have the same value only one cursor will be shown.

When viewing a histogram, the data source, the period, the range, the column width, the display of the cumulative value columns and the cursor positions can be changed using the pop-up keys.

Documenting Trends

To print a Vital Signs or Graphical Trends report,

- in the **Vital Signs** or **Graphical Trends** window, select the pop-up key **Print** to print a report for the trend group currently on the monitor screen.

Reports include the most recent information in the trends database and extend backwards in time according to the selected trend interval and your monitor's configuration. Trends reports can be printed on central or local printers.

To make a Vital Signs recording,

- in the **Vital Signs** window, select the **Print/ Record** pop-up key, then select the **Record Vitals** pop-up key.

Vital Signs recordings print the trend data for the current group and trend period shown in the **Vital Signs** window.

Trends Databases

Depending on the purchased options and the monitor's configuration, the trend databases store information for up to 100 measurements for up to 96 hours. See "Monitor Performance Specifications" on page 481 for trend database specifications.

The values in the trends database are stored as measured by the monitor, they are not averaged values. The trend resolution defines how often a value is stored. In general, if more than one value is available for storage in the trends database, the most recent value is used. Some values in the trends are marked with arrows. This indicates that for this time period, more values were available and the most recent one is shown.

Example database configuration

In this example, we see that the monitor stores the most recent data at the highest resolution, older data are stored at a lower resolution.

"4 hours @ 12 second resolution" means that the monitor stores trend data every 12 seconds, for the most recent four hours.



Aperiodic Trends Database

Aperiodic trends do not count toward the maximum number of trends allowed by the trend configuration. Trend data for aperiodic measurements is stored in a separate database and timestamped with the measurement time.

Trending Multiple-Value Measurements

Some measurements generate multiple values, for example invasive pressure measurements can provide systolic, diastolic, and mean values. These values are trended as separate measurements.

Screen Trends

Trends configured to display permanently on special monitor Screens are called Screen Trends. The selection and number of measurement waves in the Screen Trend segment depends on your monitor configuration. Screen Trends are color-coded to match the measurement wave and numerics, and they can be viewed in graphical, tabular, histogram or horizon format.

If you do not see Screen Trends on the monitor Screen, select a different Screen, one that is configured to show Screen Trends. Screen Trends are only available on specially designed Screens.

Screen Trend information is taken from the Trends database. If you do not see a Screen Trend for a particular measurement on the Screen, check the trend priority list to ensure that this measurement is being trended.

Setting the Screen Trend Time

To set the **ScreenTrend Time** for all graphical, histogram and horizon screen trends ("global" trend time),

- 1 Select a screen trend then select **Setup Trend**, or select **Main Setup** then select **Trends**.
- 2 Select **ScreenTrend Time** and select the required time: 30 minutes, one, two, four, eight, or twelve hours. This is now the Global screen trend time and defines the period of trend information shown for all screen trends.

To set a different **ScreenTrend Time** for a screen trend or a group of aligned screen trends,

- 1 Select a screen trend.
- 2 Select **Change TrendTime**.
- 3 Select the required trend time.
Selecting **Global** leaves the trend time set to the global screen trend time.

Changing the Selection of Screen Trends Displayed

- 1 Select the screen trend.
- 2 Select **Change Trend** and select the required trend from the list of available trends.
Select **Blank** to remove the selected trend from the Screen.
If you do not see **Change Trend** in the screen trend menu, the trend is aligned to display with the measurement wave. Changing the wave automatically changes the trend.

To display two or more screen trends overlapping,

- 1 Select the screen trend to open the screen trend menu,
- 2 Select **Change Trend** followed by **Add Trend** and select a screen trend from the pop-up list.

Activating the Cursor for Screen Trends

To activate the cursor for Screen Trends:

- 1 Select the screen trend.
- 2 Select **Activate Cursor**.

You can now use the arrow keys to move the cursor across the time line. The values measured at the cursor time are shown next to the cursor.

To de-activate the cursor,

- Select **Main Screen**.

Changing the Screen Trend View

To switch between tabular, graphic, histogram and horizon views, select the screen trend then select **Change View** and select the required view.

Tabular View

Aperiodic measurements such as NBP, C.O., C.I., and Wedge can be viewed as a screen trend in tabular form. The measured values and their timestamps are shown, with the measurement label.

The trend time for tabular screen trends depends on the space available on the Screen. Up to 30 measurements or 12 hours information can be shown.

Histogram View

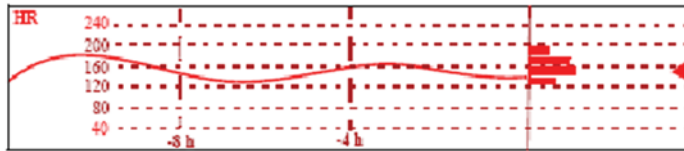

The histogram view presents a combination of graphical trend and histogram. The histogram is on the right hand side in a horizontal presentation with vertical gridlines representing 25%, 50%, 75% and 100%. Each column shows the percentage of time that the measurement values were in a specific range. This range is represented by the column's position in the graphical trend gridlines. The arrow mark next to a column shows that the currently measured value is in the range covered by that column.

If less than two-thirds of the samples are valid, a question mark will be displayed with the histogram, except when the histogram consists of intermittently measured data.

Horizon View

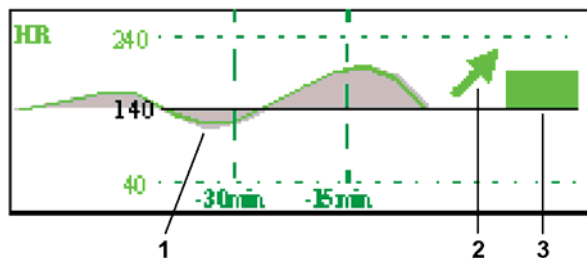

The horizon view presents trend information superimposed over a defined baseline or base range. This helps you visualize changes in your patient's condition since the baseline was set.

The horizon view is made up of:

- a horizon, drawn in white, as a reference point or baseline to help you visualize changes in your patient's condition. The horizon can be set to represent your patient's current condition, or a target condition and can be a single value or a range.
- a graphical trend, displaying patient data for the set trend time (1).
- a trend indicator arrow, indicating how the patient trend has developed in the set time period (10 minutes, 5 minutes or 2 minutes) (2).
- a deviation bar, showing how the currently measured value deviates from the set horizon (3). The height of the deviation bar is an indication of the extent of the change in your patient's condition relative to the (horizon) baseline.

Your monitor may not be configured to show all elements of the screen trend horizon view.

Setting the Horizon

The horizon is the reference value to which deviations in the measurements are compared.

To set the horizon:

- 1 Select the horizon trend.
- 2 Select
 - **Set High Horizon** to select the upper horizon value. If the high and low horizon values are the same, the horizon is a baseline - if the values are different the horizon is a range.
 - **Set Low Horizon** to select the lower horizon value.
 - **Auto Horizon** to set the horizon for the selected horizon trend to the currently-measured value.
 - **Auto All** to reset the horizon for all horizon screen trends to the currently-measured values.
 - **Set Horizon** to set the horizon to a specific value from a pop-up list.

Setting the Horizon Trend Scale

The horizon trend scale is defined with respect to the horizon. If your horizon is set to 100 and you select 20 as the horizon scale delta, the upper limit of the horizon scale will be 120 and lower limit 80.

To set the horizon trend scale delta,

- 1 Select the horizon trend.
- 2 Select **Set Scale Delta** and select a value to define the distance between the horizon and the upper and lower scale limits.

Be aware that changing the horizon trend scale can change the angle of the trend indicator, without the patient's condition having changed.

If a measurement exceeds the outer limits of the scale, the wave will be clipped and you must either reset the horizon or the horizon trend scale to display the values outside the scale limits.

Setting the Time Period for the Trend Indicator Arrow

The time period for which the trend indicator arrow is displayed can be set in the **Trends** window.

- 1 Select **Main Setup** then select **Trends**.
- 2 Select **HorizonArrowTime**.
- 3 Select 10, 5 or 2 minutes.

Calculations

Calculations are patient data that is not directly measured but calculated by the monitor when you provide it with the appropriate information.

Your monitor can perform the following hemodynamic, oxygenation, and ventilation calculations.

Hemodynamic	Oxygenation	Ventilation
Cardiac Index (C.I.)	Arterial Oxygen Content (CaO_2)	Minute Volume (MINVOL)
Stroke Volume (SV)	Venous Oxygen Content (CvO_2)	Compliance (COMP)
Stroke Index (SI)	Arteriovenous Oxygen Content ($CavO_2$)	Dead Space (V_d)
Systemic Vascular Resistance (SVR)	Oxygen Availability Index (DO_2I)	Dead Space/Tidal Volume Ratio (V_d/V_t)
Systemic Vascular Resistance Index (SVRI)	Oxygen Consumption (VO_2)	Alveolar Ventilation (ALVENT)
Pulmonary Vascular Resistance (PVR)	Oxygen Consumption Index (VO_2I)	
Pulmonary Vascular Resistance Index (PVRI)	Oxygen Extraction Ratio (O_2ER)	
Left Cardiac Work (LCW)	Alveolar-Arterial Oxygen Difference ($AaDO_2$)	
Left Cardiac Work Index (LCWI)	Percent Arteriovenous Shunt (Q_s/Q_t)	
Left Ventricular Stroke Work (LVSWS)		
Left Ventricular Stroke Work Index (LVSWSI)		
Right Cardiac Work (RCW)		
Right Cardiac Work Index (RCWI)		
Right Ventricular Stroke Work (RVSW)		
Right Ventricular Stroke Work Index (RVSWI)		
Extra Vascular Lung Water Index (EVLWI)		
Intrathoracic Blood Volume Index (ITBVI)		
Global End Diastolic Volume Index (GEDVI)		

The hemodynamic calculations available depend on the Cardiac Output measurement method being used and the regulatory standards that apply for your hospital: see the “[Monitoring Cardiac Output](#)” chapter for availability details.

Performing Calculations

You must check that all input values are appropriate for your patient before performing calculations.

- 1 Select the **Calcs** SmartKey to open the **Calculations** window.
- 2 Check the calculation time in the **Calc Time** field.

When you enter the calculation window, this field will show either the current time or the time of the most recent available C.O. measurement, depending on your monitor configuration.

 - To choose a different calculation time, select the **Calc Time** field. This calls up a list showing the timestamps of calculations performed earlier. Select a time from this list, or select **Select Time** to enter a time of your choice. The values from the Vital Signs database from the 30 minute period before the selected time will be used.
 - To enter the current time, select the **Resample Vitals** pop-up key. If you choose the current time, the monitor will resample all the required values that are monitored.
- 3 Enter any values that must be entered or edited manually. Select the value field and then use the pop-up keypad to enter the required values. Select **Enter** to confirm each entered value. Manually-entered values are marked with an asterisk (*). See “[Entering Values for Calculations](#)” on page 354 for more details.
- 4 When all values are available or entered on screen, select the **Perform Calc** key to start the calculation.

Entering Values for Calculations

The monitor automatically enters any available values for calculations. For aperiodically-measured values such as C.O., the monitor will re-use the most recent value in the calculation database until a new value becomes available. If the calculation time is the last C.O. time, values will be used from up to and including 30 minutes before the C.O. time, except for height and weight where the last available value will be used.

- To enter calculations values manually or edit automatically-entered values, select the value field to open the on-screen keyboard and use this to enter the correct value. Values edited manually are marked with an asterisk (*).

If you enter a value that has more decimal places than allowed for a particular input, the value you enter will be rounded off after you select **Enter**. If you enter a value which cannot be stored, the message **Value out of range** will appear. Enter a new value.

In hemodynamic calculations, if the systolic and diastolic pressures are manually entered, the mean pressure is calculated and marked with an asterisk (*). The formula used to estimate the mean pressure is:

$$[\text{systolic} + (\text{diastolic} \times 2)] / 3.$$

Automatic Value Substitution

If the monitor cannot find a value required for calculation, it automatically tries to find an equivalent source for this value. For example, if C.O. is required but unavailable, the monitor automatically looks for CCO as an alternative source of C.O. values, or an alternative Pressure label may be used instead of ABP. The label of the value in the **Calculations** window does not change. Substituted values are marked with an asterisk (*).

If a PAWP value is not available, PAWP will be set to zero in the formulas where it is used.

Automatic Unit Conversion

The monitor needs consistent units for performing calculations. It automatically converts units where necessary before it performs the calculation, for example, pressures sourced in kPa, cmH₂O, or mbar are automatically converted to mmHg, or to cmH₂O for ventilation calculations.

Manual Unit Conversion

If you need to convert units for other purposes you can use the **Unit Conversion** window:

- 1 Select **Main Setup** then select **Calculations**.
- 2 Select **Unit Conversion**.
- 3 Select the field under the unit you know and use the on-screen keypad to enter the known value. The converted value automatically appears in the adjacent field.

BSA Formula

Your monitor provides both the Boyd and Dubois formulas for the calculation of body surface area (BSA). For calculations, the monitor uses the setting defined in the **Patient Demographics** menu. All calculation results that use BSA are indexed to the selected formula.

- To check the current setting, select the patient name to enter the **Patient Demographics** menu. **BSA(B)** indicates that the Boyd formula is used; **BSA(D)** indicates that the Dubois formula is used.

Viewing Calculations



- Select the **Calcs** SmartKey to open the **Calculations** window.
- Select the **Calc Type** field and select the required calculation type for display.

Calculations Windows

This example calculations window shows the **Hemodynamic Calculations** window. The ventilation and oxygenation windows are similar.

Hemodynamic Calculations						×
Height	75 in				Calculation Time	
Weight	125.0 lb	BSA	1.80 m ²	19 Apr 13:56		
C.O.	8.00 l/min			C.I.	4.44 l/min/m ²	
HR	80 bpm	SV	100.0 ml	SI	55.6 ml/m ²	
ABPs	86 mmHg	SVR	510 DS/cm ⁵	SVRI	918 DSm ² /cm ⁵	
ABPd	54 mmHg	PVR	80 DS/cm ⁵	PVRI	144 DSm ² /cm ⁵	
ABPm	65 mmHg	LCW	4.7 kg-m	LCWI	2.6 kg-m/m ²	
PAPs	38 mmHg	LVS _W	58.5 g-m	LVS _W I	32.5 g-m/m ²	
PAPd	26 mmHg	RCW	1.74 kg-m	RCW _I	0.97 kg-m/m ²	
PAPm	30 mmHg	RVS _W	21.76 g-m	RVS _W I	12.09 g-m/m ²	
PAWP	22 mmHg					
CVPm	14 mmHg					

- 1 **Height** used for the calculations
- 2 **Weight** used for the calculations
- 3 **Calculation Time**
- 4 Calculations input values
- 5 Output values
- 6 Indexed calculation values

Calculations Pop-Up Keys

Depending on the calculations group you choose, a selection of pop-up keys will appear to let you navigate through the stored events and carry out calculations-related tasks.

Pop-Up Keys	Selecting this pop-up key lets you....
Resample Vitals	use the most recent monitored values. Resampling sets the calculation time to the current time, and displays the corresponding values for the previous second.
Perform Calc	perform the displayed calculation using the currently-input values and store the calculation in the calculations database
Print/Record	print or record the displayed calculation.
On/Off DateTime	toggle between showing the date and time or the units for the calculation input values.
On/Off Ranges	toggle between showing the normal ranges or the units for the calculation output values.
Cardiac Output	access the C.O. procedure window.
Hemo Review	open the hemodynamic calculations review window.
Vent Review	open the ventilation calculations review window.
Oxygen Review	open the oxygenation calculations review window.

Reviewing Calculations

To enter the calculations review window, select the **Oxygen Review**, **Vent Review**, or **Hemo Review** pop-up key as required.

The review window lists all the input and output values for each measurement in the calculations group. The timeline in the review window lists the times the calculations were performed.

To review individual calculations, select the calculation in the review window and then select the **Original Calc** pop-up key.

The storage time for calculations is the same as the trend database storage time configured for the monitor. So if trends are stored for 48 hours, the calculations will also be stored for 48 hours.

Documenting Calculations

To send a Calculations recording to a connected recorder, in the **Calculations** window, select the **Print/Record** pop-up key, then select the **Record Calc** pop-up key.

Calculations recordings print the patient demographic information and the content of the current **Calculations** window on the recorder strip.

To print a report for the calculation group currently on the monitor screen, select the pop-up key **Print Calc**. To print the review window, select the pop-up key **Print** in the review window. All the calculations in the current group will be printed in the report.

Calculation reports can be printed on central or local printers.

This example report shows the oxygen calculation group. Ventilation and hemodynamic calculation reports are similar.

1	Bob Jones		123456						
2	Oxygen Calculations								
Calculation Time 4 Apr 02 12:24									
	Time	Units	Range	Units	Range	Units			
	C.O.	3.61 12:24	l/min	16.2	17.20	ml/dl			
	FIO2	*0.85 12:24		20.8	22.24	ml/dl			
	PaO2	*50 12:24	mmHg	5.5	4.2-5.0	ml/dl			
	PaCO2	*55 12:24	mmHg	308	350.1150	ml/min			
	SpO2	*80 12:24	%	198		ml/min			
	PvO2	*35 12:24	mmHg	0.24	0.28				
	SvO2	*53 12:24	%	50.7	10.15	mmHg			
	Hb	*15.0 12:24	g/dl	50.5	3.5	%			
	EB	*760 12:24	mmHg						
	Height	185 12:24	cm						
	Weight	85.0 12:24	kg	2.09	m2				
						DO2I	380	550.650	ml/min/m2
						VO2I	29.5	115.165	ml/min/m2
3									
PHILIPS					General Hospital		Page 1 (last)		

- 1 Patient information
- 2 Calculation group
- 3 Three columns of calculations input and output values, with times, units and ranges, where appropriate

High Resolution Trend Waves

High resolution (hi-res) trend waves provide information for fast-changing parameters at a glance. They can help you to recognize trend patterns and to find interrelationships between measurements, by comparing changes in your patient's condition across different hi-res trend waves.

The amount of data you can show on a screen depends on the display size and resolution: for example, on an eight inch (20 cm) wave trace on your monitor screen, you can view approximately six minutes of hi-res trend wave trace. The hi-res waves are drawn at a speed of 3 cm/minute.

The availability of hi-res trend waves depends on your monitor configuration and on the options purchased for your monitor.

Changing the Hi-Res Trend Waves Displayed

To change the selection of hi-res trend waves on the Screen:

- 1 Select a displayed hi-res trend wave.
- 2 Select the required hi-res trend wave from the pop-up list.

If there are no hi-res trend waves on the Screen, you must change to a Screen with hi-res trend waves.

Hi-Res Trend Wave Scales

Hi-res trend waves are either compressed realtime waves or fast numeric trends.

- Hi-res trend waves from compressed realtime waves include: Resp, CO₂, ABP, PAP, CVP, ICP, AWP, anesthetic agents.
- Hi-res trend waves from fast numeric trends include: btbHR, SpO₂, tcpO₂, tcpCO₂, Pulse, Perf, CPP, BIS, CCO, inO₂, Delta SpO₂.

Hi-res trend waves from realtime waves use the wave scale as their display scale. Changing the wave scale changes the hi-res trend wave scale.

Hi-res trend waves from numerics use a pre-defined display scale dependent on the patient category.

Hi-Res Trend Waves and OxyCRG

OxyCRG is a combination of three hi-res trend waves, btbHR, SpO₂, and Resp, mainly used in neonatal monitoring.

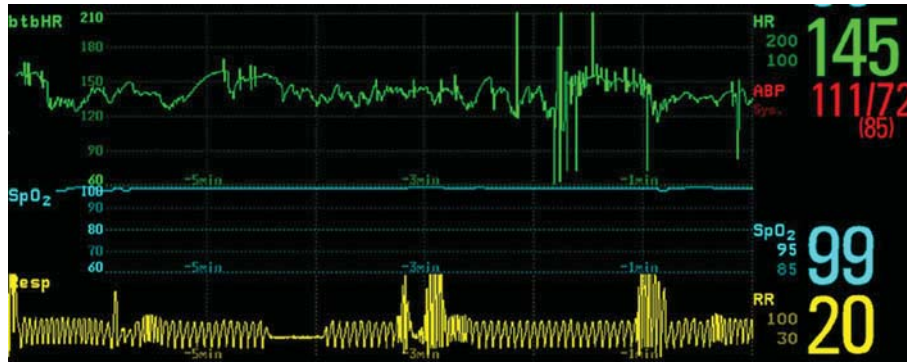

Printing Hi-Res Trend Wave Reports

To print hi-res trend waves on reports, you can choose to print either

- all **VisibleWaves** - prints all waves and hi-res trend waves currently displayed
- **All Waves** - prints realtime waves and hi-res trend waves for all currently-monitored measurements
- **HiRes Waves** - prints hi-res trend waves for the currently-monitored measurements
- **OxyCRG Waves** - prints hi-res trend waves for btbHR, SpO₂, and Resp.

For each hi-res trend wave, a maximum of six minutes of measurement data will be printed.

See the “[Generating Patient Reports](#)” chapter for more information on setting up reports.

Hi-Res Trend Wave Recordings

The selection of waves in hi-res trend wave recordings and the recording speed are defined by the pre-configured HiResTrd recording template. See for more information.

To start a hi-res trend waves recording,

- 1 select the **Recor- dings** SmartKey, if configured, or select **Main Setup** then select **Recordings**.
- 2 select the **HiRes Recordng** pop-up key.

Event Surveillance

Events are electronic records of episodes in your patient's condition. You can trigger them manually, or set them to trigger automatically during pre-defined clinical situations.

Depending on the level of event surveillance available on your monitor, the information stored for each event episode can include:

- the event trigger
- waveforms for up to four measurements of your choice (depending on episode type, see “Event Episodes” on page 363 for more details)
- numeric vital signs for up to 30 measurements
- any alarm conditions active when the event episode was triggered
- any annotations connected with the event.

You can navigate through the event database to view events retrospectively, and you can document events on a recording or report marked with the patient name, bed label, and the data and time.

Levels of Event Surveillance

The appearance of the Events windows and menus and the settings you can select for events depends on the event surveillance option purchased for your monitor: basic event surveillance, advanced event surveillance, or neonatal event review (NER). This table lists the differences between the options.

To determine which level of event surveillance your monitor has, select **Main Setup** then **Event Surveill.** followed by **Setup Events** and select the trigger group to see the available event groups.

- If the only event groups listed are **NER** or **CAR**, your monitor has the Neonatal Event Review option.
- If only one event group can be activated and it is not **NER** or **CAR**, your monitor has the Basic Event Surveillance option.
- If six event groups can be activated, your monitor has the Advanced Event Surveillance option.

Event Functionality	Basic Event Surveillance Option C06	Advanced Event Surveillance Option C07	Neonatal Event Review (NER) Option C04
Event groups	10 (One can be activated. NER and CAR are not available.)	10 (Six can be activated. One group can be configured to CAR.)	10 (One can be activated. One group can be configured to CAR.)
Measurements per group	3	4	3 (plus 1 for episode recording)
Triggers per measurement	1	2	1
Trigger types	Alarm User-defined thresholds On occurrence	Alarm User-defined thresholds On occurrence Deviation triggers	Alarm User-defined thresholds On occurrence

Event Functionality	Basic Event Surveillance Option C06	Advanced Event Surveillance Option C07	Neonatal Event Review (NER) Option C04
Trigger condition	Simple ("at least one")	Combined ("e.g. at least two")	Simple ("at least one")
Annotation	no	yes	yes
Types of event episode	Average trend Snapshot events	Average trend High resolution trend Snapshot events	High Resolution Trend
Event Notification	no	yes	no
Pop-up	no	configurable (no/yes)	no

Event Groups

The event group

- monitors the patient's signals to detect events
- defines which waveforms are recorded in the event data.

In Basic Event Surveillance and Neonatal Event Review only one event group can be active at a time, with Advanced Event Surveillance all six groups can be active simultaneously. Active event groups monitor for event triggers.

Event groups are defined in Configuration Mode or in the Event Surveillance Editor using the IntelliVue Support Tool. In monitoring mode the groups can be adapted to current conditions, for example episode types and threshold levels can be changed.

Activating Event Groups

To activate an event group:

- 1 Select **Main Setup** then **Event Surveill.** followed by the group you would like to activate.
- 2 Activate the group by selecting a group type. Select **Off** to deactivate the group.

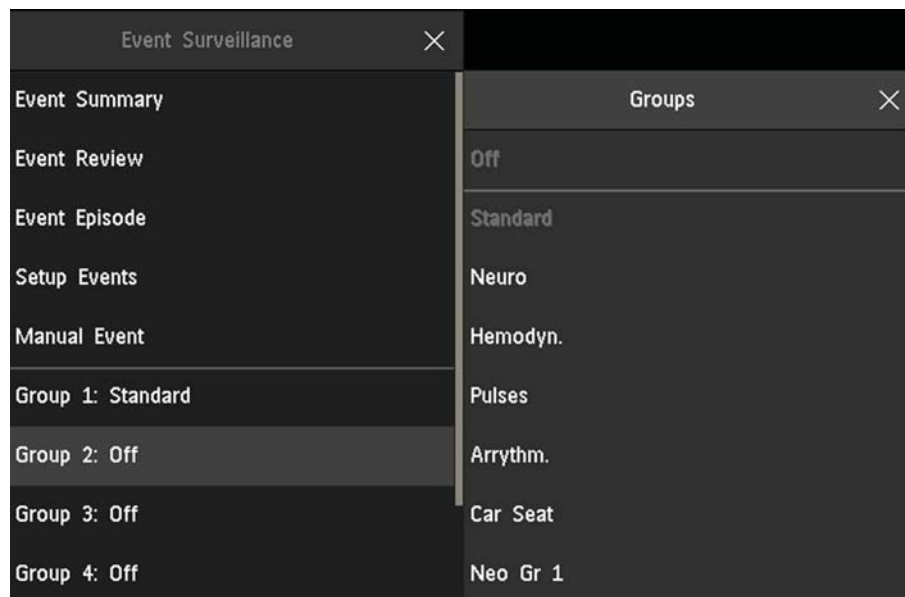

Event Episodes

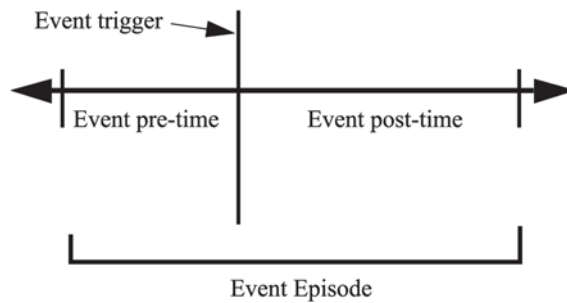

When an event occurs, information for a predefined duration is stored. This is the event episode. It includes information from a defined period before the trigger, called the event pre-time. The episode time after the event is called the event post-time. If a further event occurs during the event post-time it changes a single event to a combined event (combi-event).



Manually-triggered event episodes document patient information from the time leading up to the event trigger; they do not have a post-time.

The episode type defines the level of detail captured in an event episode. The higher the data resolution, the shorter the period that the monitor can store in its memory. High-resolution data is suited for neonatal applications, where the clinical situation may change very quickly. In adult monitoring, where the patient's status typically changes more gradually, a longer trend may be more informative.

Event Episode Types	Pre-time	Post-time
Average trend 20 minutes, five samples per minute	2 minutes	18 minutes
	4 minutes	16 minutes
	6 minutes	14 minutes
	8 minutes	12 minutes
	10 minutes	10 minutes
	12 minutes	8 minutes
	14 minutes	6 minutes
	16 minutes	4 minutes
HiResTrend Four minutes, four samples per second.	1 minute	3 minutes
	2 minutes	2 minutes
	3 minutes	1 minute
Realtime Wave Snapshot 15 seconds	5 seconds	10 seconds
	10 seconds	5 seconds

Events Pop-Up Keys

Depending on the events view you choose, a selection of the events pop-up keys let you navigate through the stored events and carry out events-related tasks.

Pop-Up Keys		Selecting this pop-up key lets you....	
Event Setup		open the Event Setup menu.	
Show Episode		open the Event Episode window to review the selected event in detail.	
Show Review		open the Event Review window.	
Review Group		choose a different event group for reviewing in the Event Review window (Advanced Event Surveillance only).	
Show Summary		open the Event Summary window.	
Manual Event		start a manually-triggered event capture.	
Start CAR	Stop CAR	open the Start CAR window to start a Car seat Assessment Record (CAR) period or stop a currently running CAR.	
CAR Histogram		open the window showing the CAR SpO ₂ histogram	
		move the cursor left or right to the next event to navigate through the events database. Placing the cursor over an event highlights it and shows the event values for the selected event.	
		jump to the first or last event in the event database.	
Vitals View	Graphic View	toggle between a tabular and graphic version of the Event Episode window currently viewed.	
Table Review	Graphic Review	CAR Review	toggle between a tabular and graphic version of the Event Review window currently viewed.
Delete Event		delete the currently-selected event from the database. The monitor asks you to confirm this deletion. You cannot retrieve deleted events.	
Select Annotatn		access the list of available annotations to add a nursing note for the current event episode (Advanced Event Surveillance only).	
Print/ Record		access the printing and recording pop-up keys to document events.	

Event Triggers

You can trigger event capture manually, for example, if you want to record a patient's condition before a procedure. You can also set events to trigger automatically, when the patient's values cross a predefined threshold value, or when a particular measurement or procedure is carried out.

If more than one trigger is available for the measurements in the active event group, the trigger condition may be **At least one Param.**, **At least two Param.**, **At least three Par.**, or **All four Parameter**. If the trigger is **At least one Param.** (this is short for "at least one measurement parameter"), the monitor starts an event capture if a trigger occurs in any of this event group's measurements. If the trigger is **At least three Par.**, the monitor captures events when three or more trigger thresholds from this event group's measurements are violated. With **Enhanced Condition** you can not only select a minimum number of triggers to trigger an event but define which specific measurement triggers these must be. For example, **At least two Param.** will cause an event to be captured if a trigger occurs in any two of this event group's measurements - with **Enhanced Condition** you can select that only when triggers are in HR and SpO₂ an event will be captured.

	Single	Pair	Triple	All
ΔQTc	<input type="radio"/>	<input checked="" type="radio"/>	<input type="radio"/>	<input type="radio"/>
ΔSpO ₂	<input type="radio"/>	<input checked="" type="radio"/>	<input type="radio"/>	<input type="radio"/>
ABP	<input type="radio"/>	<input checked="" type="radio"/>	<input type="radio"/>	<input type="radio"/>
Active	<input type="radio"/>	<input type="radio"/>	<input checked="" type="radio"/>	<input type="radio"/>

At least one Param. At least two Param. At least three Par. All four Parameter

The trigger condition for event groups is set in the monitor's Configuration Mode.

Parameter keys - let you define how many measurements must have a trigger before an event capture is started.

At least one Param.

At least two Param.

At least three Par.

All four Parameter

Enhanced Condition boxes - let you limit the triggers to specific measurements or measurement combinations

Single - select one measurement

Pair - select combination of two measurements

Triple - select combination of three measurements

All - all measurements

If You Use Alarm Limits As Event Triggers

The event capture is triggered automatically when your patient's values violate set alarm limits, or when a specified alarm condition, such as apnea, occurs. No events of this kind are triggered if alarms are switched off. Changing alarm limits changes the event trigger definitions.

The asterisk symbols beside the trigger tell you about the alarm triggers:

*** indicates a high priority (red) alarm

** indicates a lower priority (yellow) alarm. This category includes short yellow arrhythmia alarms, which may be configured to be shown as one star alarms (*) on your monitor.

Triggers without asterisk symbols are user-defined triggers.

If You Set User-defined Threshold Triggers

You can define event triggers that are independent of alarm limits. You must set a threshold value and a threshold time for the trigger. If you set the trigger threshold time to e.g. 12 seconds, the monitor triggers an event if the threshold is violated for more than 12 seconds.

If You Set "On Measurement" Triggers

You can set aperiodic measurements (such as NBP) or procedures (such as Cardiac Output) to trigger an event whenever they start.

If You Set User-defined Deviation Triggers

You can define event triggers that are independent of specific limits and based instead on deviations from the current values. You must set a deviation and a period of time in which the deviation occurs. There are three types of deviation available: **Any Deviation**, **Up Deviation** where only changes in a positive direction are detected and **Down Deviation** where only changes in a negative direction are detected. The deviation can be defined either in relative terms as a percentage, for example 10%, or as an absolute value, such as 10 bpm.

Event Retriggering

If a condition that triggered an event persists and the values remain beyond the trigger threshold, a new event will not be triggered.

For a new event to be triggered by the same condition, the measured values for at least one of the triggers must cross back into the normal range and then recross the trigger threshold.

Event Notification

Advanced Event Surveillance Only

You can be notified when an event is detected. For each event group you can define a type of notification depending on the severity of the event conditions. The notification can be a status message with a prompt tone or a standard *, **, or *** alarm notification. These event alarms are handled exactly like measurement alarms; they can be acknowledged and are also suspended when all alarms are suspended. You should only use alarm notification for events which are comparable in severity to standard measurement alarms to avoid potential confusion due to too many alarms. Selecting **None** switches event notification off.

Setting the type of notification, or switching notification off, is done in Configuration Mode.

Setting Triggers for NER and Basic Event Surveillance

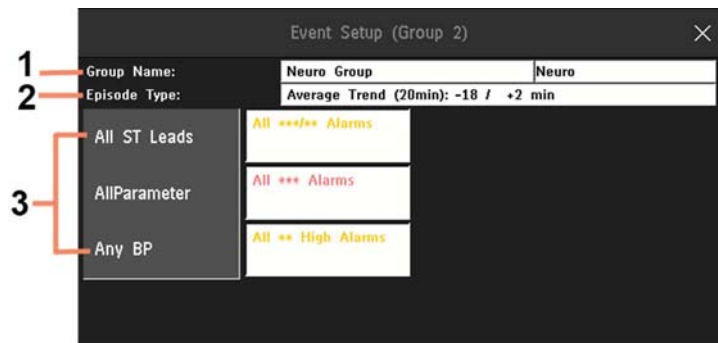

- 1 **Group Name** can be up to 20 characters long. The second field is limited to 8 characters. This shorter name is used if there is not enough room in the window or the report to display the full group name.
- 2 The **Episode Type** determines the pre and post time.
- 3 Measurements used as event triggers.

- 1 Select **Main Setup** then **Event Surveill.** followed by **Setup Events** to enter the **Event Setup** window.
- 2 Select the name of the current episode type to set the episode pre/post time.
- 3 Set the event trigger for each measurement. Select each trigger name and select, if available, either an alarm trigger, or a user-defined trigger from the pop-up trigger list. If you select a user-defined trigger, set the required threshold level and delay time.
- 4 Select **Confirm** to confirm your changes.

Setting Triggers and Notification for Advanced Event Surveillance

Measurement	Trigger	Value	Unit	Delay	Unit
ΔQTc	All *** High Alarms				
	** High				
ΔSpO ₂	Any Deviation	13	% (dev)	within	50 sec
	High	38	%	for	900 sec
ABP	All *** Alarms				
	All ** Low Alarms				
Pat.Activity	Up Deviation	5	% (dev)	within	22 sec
	Low	3	%	for	77 sec

- Group Name** can be up to 20 characters long. The second field is limited to 8 characters. This shorter name is used if there is not enough room in the window or the report to display the full group name.
- Group Type** shows the currently configured type for this group.
- Notification Type** shows the currently configured notification
- Episode Type** determines the pre and post time
- Trigger Condition** shows the currently configured trigger requirements
- Measurements used as event triggers

- Select the group name to enter the setup window for that group.
- Set the episode type.
Select the name of the current episode type and select an episode type from the pop-up list. The pre/post episode time for the selected episode type is displayed.
- Set the trigger for each measurement. Select each trigger name and select either an alarm trigger or a user-defined trigger from the pop-up trigger list. If you select a user-defined trigger, set the required threshold level and delay time. If a deviation trigger is configured, set the deviation and duration.
- Select **Confirm** to confirm your changes.

Triggering Events Manually

To manually trigger an event, select the SmartKey **Manual Event** and (for Advanced Event Surveillance) select the group in which the event will be triggered.

For manually-triggered events, patient information for the time leading up to the trigger moment is stored using the settings of the assigned event group.

Running a Car Seat Assessment Record

In the **CAR** group you can run a Car Seat Assessment Record (CAR). This is a special period of event surveillance using the current setup of the CAR group.

To start a CAR period:

- Select the **Start CAR** pop-up key or SmartKey.
- Select the required time period for the assessment.
- Select **Confirm** to start the CAR.

If the **CAR** group was not active it will be activated automatically.

NOTE

Once a new CAR period is started, the previous CAR period is deleted and overwritten.

During the CAR period an SpO₂ histogram is also generated with 1 second samples. For general information about the presentation of data in a histogram, see “[Viewing Histogram Trends](#)” on page 344. The CAR SpO₂ histogram is unique: it can only be accessed from the events function. It is generated from the beginning of the CAR period (contrary to the non-SpO₂ histograms which are generated from trended data retrospectively at the end of a time period). Settings are fixed for this histogram and cannot be changed when viewing it.

The Events Database

The maximum number of events that can be stored in the event database depends on the database configuration. The event database is set up in the monitor's Configuration Mode. Events are stored in the monitor's event database for the configured lifetime, either 8 hours or 24 hours or 7 days. Deleted events cannot be retrieved. Events are automatically deleted when:

- their configured lifetime is over
- the storage capacity of the database is exceeded (storing a further event deletes the oldest event in the memory)
- a patient is discharged.

As the event database is cleared when you discharge a patient, you should ensure that you have documented any events you require for the patient records including completed CAR periods before you confirm the discharge.

Viewing Events

- To see a summary of all the events in every group in the event database, use the **Event Summary** window.
- To review all the events in a particular event group, use the **Event Review** window.
- To review individual event episodes in detail, use the **Event Episode** window.

To start viewing events, either:

- in the **Main Setup** menu, select **Event Surveill.** and then select the event view you require from the list, or
- select the **Event Surveill** SmartKey

and then select the event view you require from the list.

Event Summary and Event Counter







Vertical bars mark events in the **Event Summary** window. The timeline shows the position of the stored events in the event database. Selecting this view activates a cursor that lets you navigate across the timeline. Use the **Show Episode** pop-up key to select individual events for review in the **Event Episode** window. It also calls up the events pop-up keys.

The event counter counts the total number of events in the database. If more than one event group was set to trigger events within the event history, the event counter also counts the event group totals.

Event Summary Window

The **Event Summary** window shows the number of stored events in each event group and the total number of events in the database. Vertical bars mark events on a timeline showing the position of the stored events in the event database. The symbol next to the group name indicates the activation and notification status:

symbol	meaning
	group activated, notification set to ***alarm
	group activated, notification set to **alarm
	group activated, notification set to *alarm
	group activated, notification set to screen prompt
	group is activated, notification is switched off
no symbol	group not activated

Selecting the **Event Summary** window calls up the events pop-up keys.

Parts of the **Event Summary** window can also be embedded in Screens so that they are always visible, for example the **Total** row showing the total number of events with the bars on the timeline or the column showing all the groups with the activation and notification status.

Event Review Window

To enter the **Event Review** window, select the graphic event summary, if available, or select the events pop-up key **Show Review**.

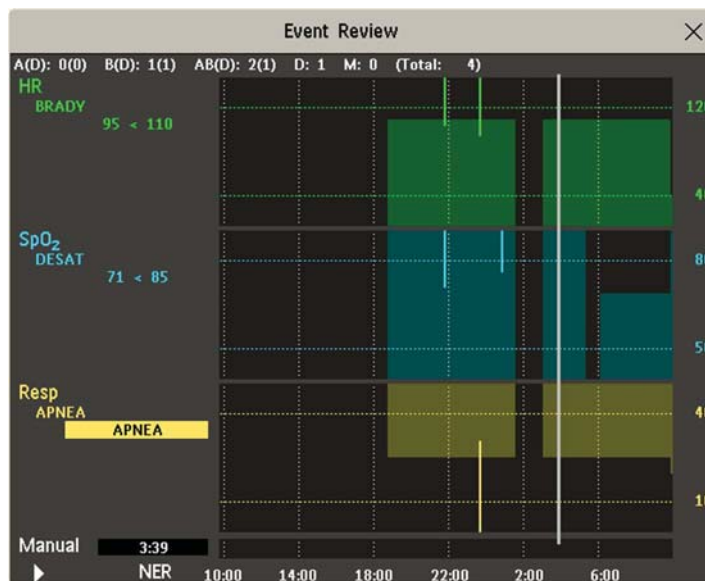

When you open the **Event Review** window, it automatically shows the event group with the most recent event.

- To view other event groups, select the pop-up key **Review Group** and select the group from the list.

Counting Combi-Events

If one or more events occur during the same Episode Time, the monitor combines them and displays them as distinct events in one event episode, called a combi-event. The first event is the trigger event, and the others are follow-up events. For example, if an apnea event is followed 40 seconds later by a brady event, the brady event is not counted as a single event but as part of the apnea event.

Counting Neonatal Event Review (NER) and CAR Events

For neonatal events (NER, formerly "OxyCRG") and CAR events, apnea events (A), bradycardia events (B), and combinations of these events are counted and classified by the event counter in the **Event Summary**. If they are associated with a Desaturation (D), this is also marked. Manual events (M) are counted separately. For example, A(D):2(1) indicates that two apnea events occurred and one of them was associated with a desaturation.

Event Episode Window

To enter the **Event Episode** window, select the pop-up key **Show Episode**.

Depending on the event group settings, the **Event Episode** window shows either 20 minutes of average trend event information, four minutes of high-resolution event information, or 15 seconds of realtime wave information.

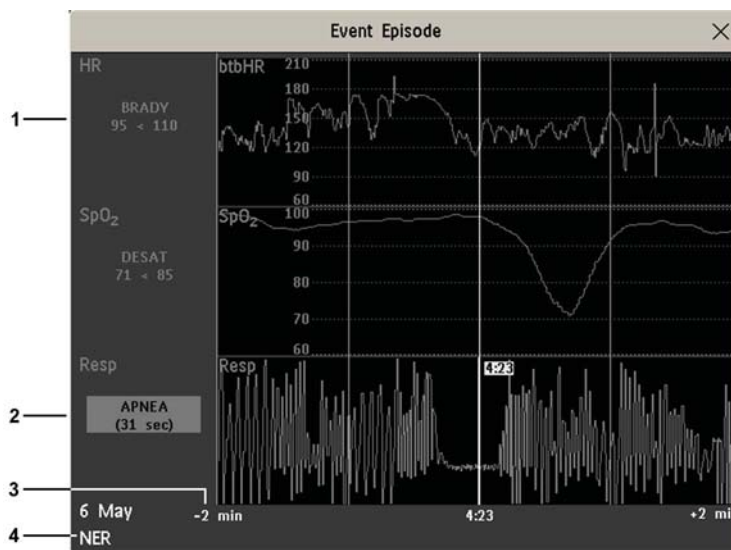

- 1 Follow-on event values
- 2 Trigger event values, highlighted
- 3 Timeline, showing episode Pre/Post-time
- 4 Active event group

The event values to the left of the measurement channels show the trigger threshold set and the maximum amount by which this limit was exceeded. In this example, Desat 71<85 tells you that 71 was the lowest SpO₂ value measured during the event time and that the Desat trigger threshold was set to 85 when the event was triggered. If the event was manually triggered, the event value boxes display "manual".

Vital Signs View

With Advanced Event Surveillance and Neonatal Event Review, you can change the graphical event episode view to a vitals view by selecting the **Vitals View** pop-up key. Displaying the vitals of an episode allows the clinician to view all vital signs measured at the time of the event as well as the alarms and inoperative conditions present.

Event Episode		Alarms / INOPs	
HR	142 bpm		
SpO ₂	97 %		
RR	0 rpm	*** Apnea	
NBP	85/50 (62) mmHg (13 Aug 14 6:40)		
ABP	-?-/-?- (-?-) mmHg	ABP	Check Cal
Perf	3.7		
Temp	37 °C		
NER			

Annotating Events

- 1 To annotate an event, in the **Event Episode** window, select the pop-up key **Select Annotatn.**
- 2 Select the required annotation from the pop-up list of available annotations for the currently active event group.

Up to 20 annotations can be configured to let you add commonly-used clinical notes to event episodes for documentation purposes. To see the complete list of available annotations, in the **Event Setup** menu, select **Event Annotation.**

Documenting Events

You can print a report or make a recording of the events history stored in the database or of individual event episodes or a Car Seat Assessment Record.

Documenting Event Review

- 1 In the **Event Review** window, select the pop-up key **Print/ Record.** This calls up the event documentation pop-up keys.
- 2 For a graphic Event Review recording, select the **Record Summary** pop-up key.
For a tabular Event Review recording, select the **Record Tabular** pop-up key.
For a CAR review report, select the **Print CAR** pop-up key
To print an Event Report, select the **Print Review** pop-up key.
To print an event summary report, select the **Print Summary** pop-up key.

Documenting an Event Episode

- 1 In the **Event Episode** window, select the pop-up key **Print/ Record.** This calls up the event documentation pop-up keys.
- 2 To make an Event Episode recording, select the **Record** pop-up key.
To print an Event Episode, select the **Print Episode** pop-up key.

Event Recordings

Event recordings can be sent to a locally-connected M1116B/C recorder module.

Event Review Recordings

Each event review recording strip begins with a summary of the events stored in the event database. Recording strip annotation is explained in the Recording chapter.

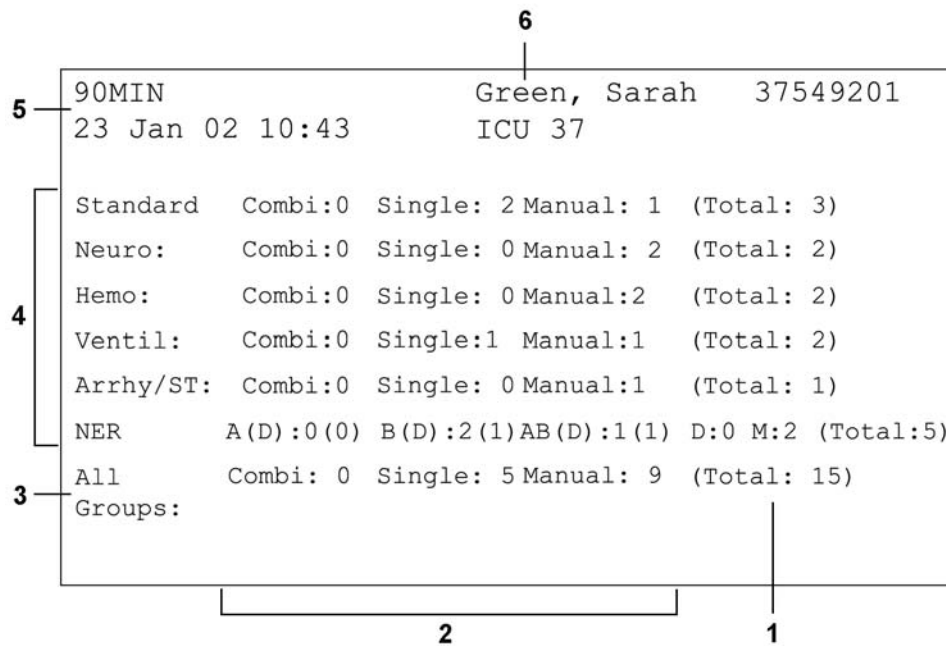

- 1 Event total per event group
- 2 Event types
- 3 Total events in database
- 4 Event groups
- 5 Recording strip code
- 6 Patient information and medical record no.

In graphic event review recordings, events are represented by bars, and each event group is printed on a separate channel.

The timeline reflects the period stored in the database, either 24 hours (divided into 4 hour sections) or 8 hours (divided into one-hour sections).

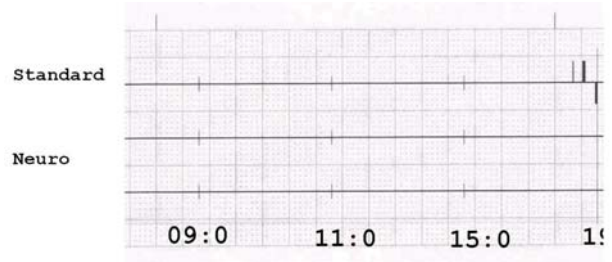

#	Time	Group	Parameter 1	Parameter 2
1	23 Jan 02 07:56	Neuro	Resp	BIS LOW 51<60
2	23 Jan 02 07:59	Standard	HR(Pulse) TACHY 201>180	ST-II
3	23 Jan 02 08:02	NeuroResp	HIGH 76>60	BIS
4	23 Jan 02 08:12	Standard	HR(Pulse)	ST-II Manual
5	23 Jan 02 08:32	Standard	HR(Pulse)	ST-II
...				

In tabular event review recordings, the events stored in the event database are shown in chronological order, with a number and time-stamp.

The measurements in the event group are shown in the next columns, marked "Parameter 1, Parameter 2...", along with the event values measured at the time of the event. For each event, the trigger values are shown.

This section of the recording is A4 or letter size, so that it fits in a patient file.

Event Episode Recordings

Event episode recordings are divided into four sections.

The first section shows the patient information and the event group of the episode with the event values for the group measurements. The trigger symbol marks the event trigger.

91MIN	Green, Sarah
37549201	
23 Jan 02 10:43	NER
Standard:HR(Pulse)	
	TACHY 130>120
SpO2	
	Resp HIGH 80>75

The second section (2 below) shows the waveforms recorded during the episode. The trigger moment is marked with a triangle and divides the episode into the pre/post time. Any calibration marks and grid marks on the screen are automatically printed on the recording.

If there are four measurements in the event group being recorded, two waveforms will be recorded in two separate waveforms segments.

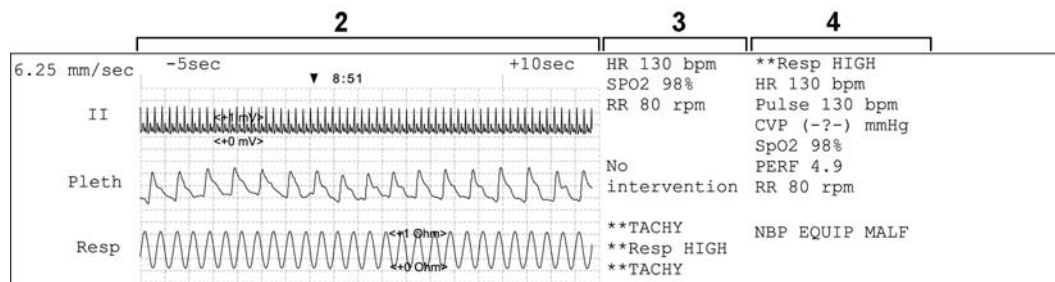

The third section (3 above) shows the most important vital signs information, including numerics, active alarms, and any annotations made on the event episode.

The fourth section (4 above) shows the numerics for all the currently monitored vital signs and any alarm conditions or INOPs active at the time the event was triggered.

Event Reports

Event reports can be printed on A4 and letter size paper on a printer connected locally or centrally to your monitor.

Event Review Reports

The event review report documents all the events stored in the event database for a selected group.

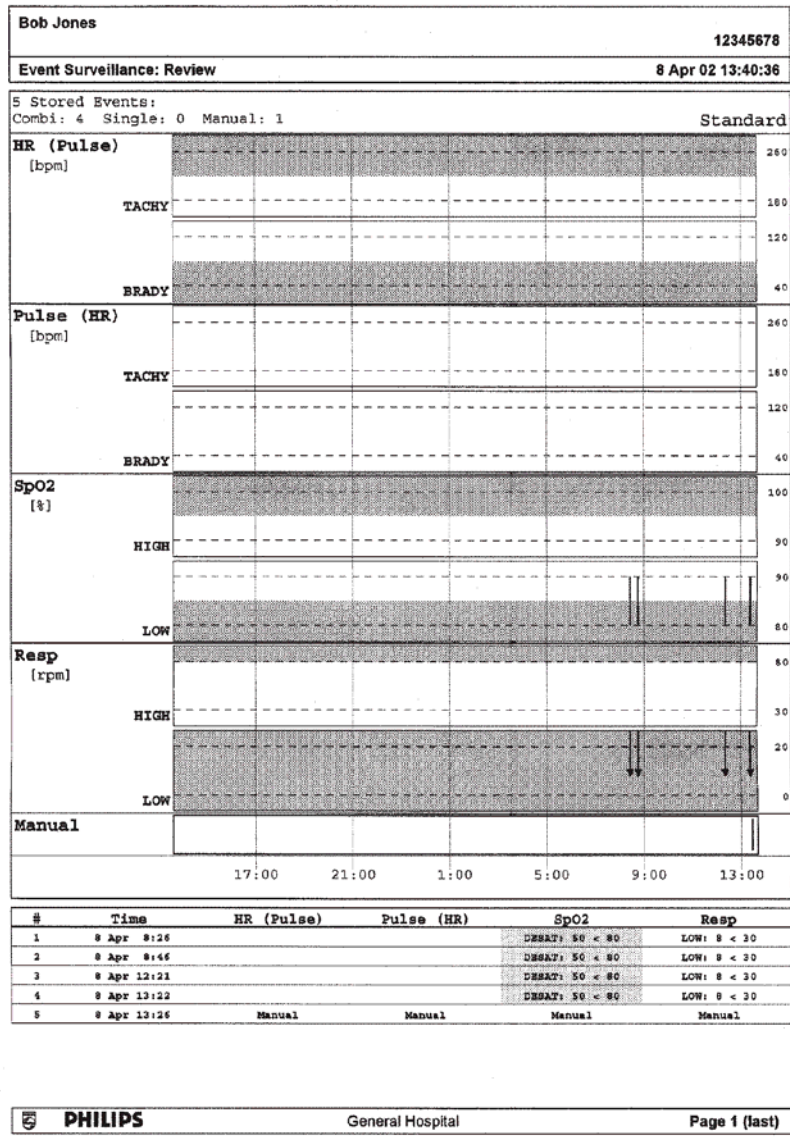

CAR Review Reports

The CAR review consists of the information in the Event Review Report over the CAR period and in addition:

- the SpO₂ histogram
- statistics for the CAR period (beginning and end, duration, number of events)
- empty fields for gestational age, last feeding time, car seat, name of caregiver, and result



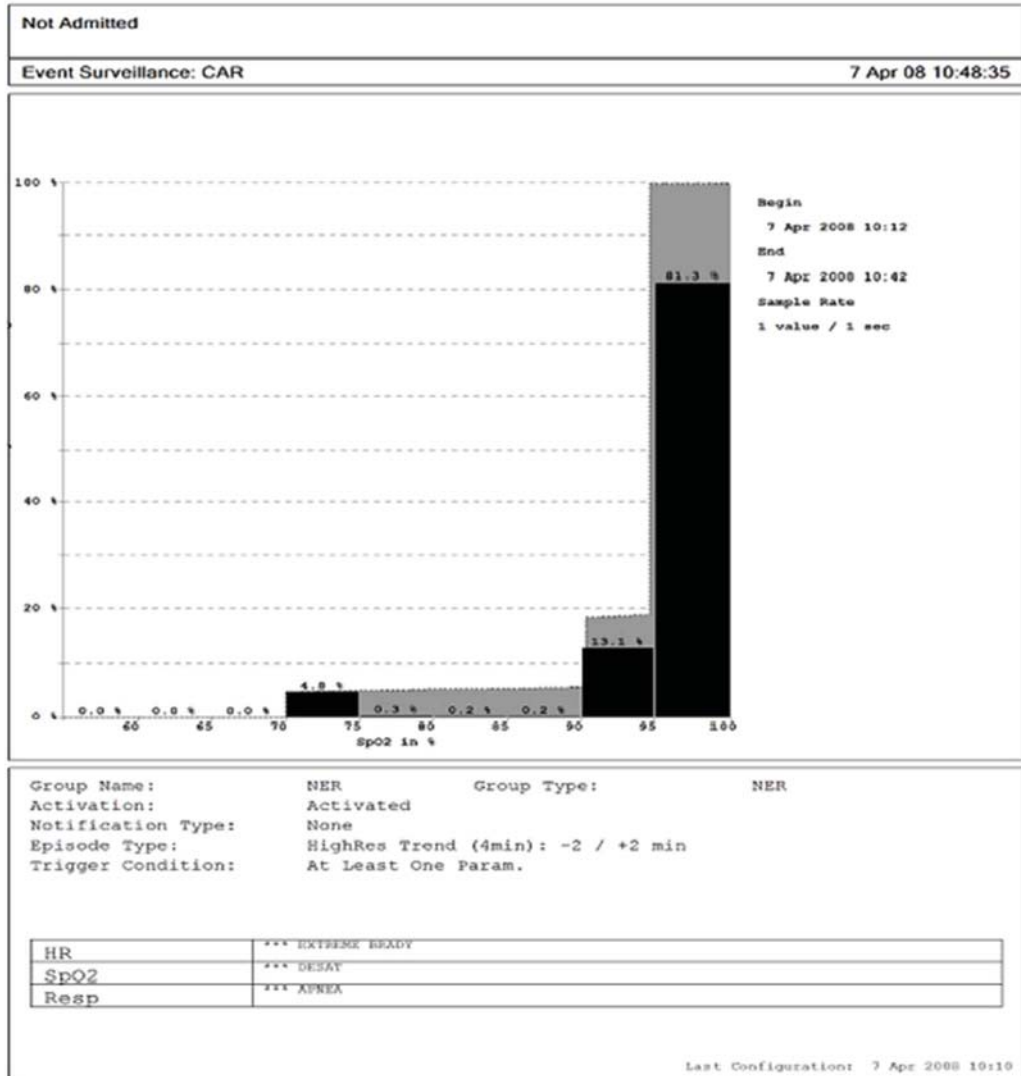

Not Admitted	
Event Surveillance: CAR	7 Apr 08 10:48:35
CAR Period	
Begin	7 Apr 2008 10:12
End	7 Apr 2008 10:42
Duration	0:30
	Number Of Events 3
Patient Data	
Gestational Age	_____

Last Feeding Time	_____

Equipment	
Car Seat	_____

Nurse	_____

Comment	

Result	<input type="checkbox"/> Passed
	<input type="checkbox"/> Failed
	_____ <i>Signature</i>

Event Episode Reports

The event episode report documents the patient information from the currently-selected event. See “Event Recordings” on page 371 for an explanation of the report elements.

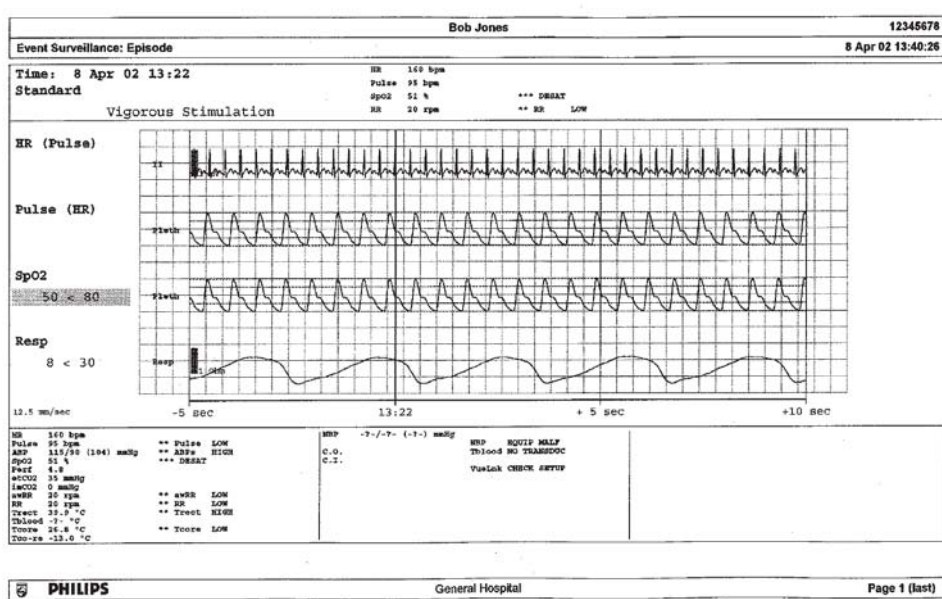

Event Summary Reports

(Advanced Event Surveillance only). The event summary report shows a graphical view and a tabular view of all events in the database for all groups.

Bed13		Event Surveillance: Episode				25 Oct 04 18:41:18
Standard						
Combi:	0	Single:	1	Manual:	0	(Total: 1) (?)
Neuro						
Combi:	0	Single:	0	Manual:	0	(Total: 0)
Hemo						
Combi:	0	Single:	1	Manual:	1	(Total: 2) (?)
Ventil.						
Combi:	0	Single:	5	Manual:	0	(Total: 5) (?)
Arthy/ST						
Combi:	0	Single:	0	Manual:	0	(Total: 0)
NER						
A(D):	0(0)	B(D):	0(0)	AS(D):	0(0)	D: 3 M: 0 (Total: 3) (?)
All Groups						
Combi:	0	Single:	10	Manual:	1	(Total: 11) (?)
22:00	2:00	6:00	10:00	14:00	18:00	
#	Time	Group	Parameter 1	Parameter 2	Parameter 3	Parameter 4
1	25 Oct 17:46	Ventil.		SpO2: LOW: 78 < 90		
2	25 Oct 17:46	Hemo	HR (pulse): Manual	SpO2: Manual	ABP: Manual	CVF: Manual
3	25 Oct 17:54	Ventil.		SpO2: LOW: 78 < 90		
4	25 Oct 17:54	Standard		SpO2: LOW: 78 < 90		
5	25 Oct 17:54	Hemo		SpO2: LOW: 78 < 90		
6	25 Oct 17:54	NER		SpO2: DESAT: 78 < 80		
7	25 Oct 17:56	Ventil.		SpO2: DESAT: 78 < 80		
8	25 Oct 17:58	NER		SpO2: DESAT: 78 < 80		
9	25 Oct 18:00	Ventil.		SpO2: LOW: 78 < 90		
10	(25 Oct 18:37)	Standard		SpO2: DESAT: 78 < 80		
11	(25 Oct 18:37)	Hemo		SpO2: DESAT: 78 < 80		
12	25 Oct 18:37	Ventil.		SpO2: DESAT: 78 < 80		
13	25 Oct 18:37	NER		SpO2: DESAT: 78 < 80		
14	(25 Oct 18:40)	Ventil.		SpO2: LOW: 78 < 90		
15	(25 Oct 18:40)	NER		SpO2: DESAT: 78 < 90		

ProtocolWatch

ProtocolWatch (PW) is a clinical decision support tool. It allows you to run a clinical protocol which can monitor developments in the patient's condition, taking into account:

- measured values from the monitor
- values manually entered by you (for example manual temperature measurements, lab values)
- your assessment of patient status

ProtocolWatch notifies you when certain conditions or combinations of conditions occur and it documents developments in a log which can be printed.

SSC Sepsis Protocol

The SSC (Surviving Sepsis Campaign) Sepsis Protocol is a protocol implemented for the ProtocolWatch application. The SSC Sepsis Protocol is for use in screening for severe sepsis and monitoring of its treatment. It is a computerized implementation of the "Surviving Sepsis Campaign: International Guidelines for Management of Severe Sepsis and Septic Shock: 2012" Crit Care Med; 2013 41(2) 580-637. Philips does not make any claims about their effectiveness to reduce the morbidity or mortality associated with severe sepsis.

The SSC Sepsis Protocol assists you in recognizing the early signs and symptoms of sepsis by comparing the state of your patient to the defined criteria and then guides you through the recommended treatment protocol. Use of the SSC Sepsis Protocol requires thorough knowledge of the complete SSC Guidelines for Management of Severe Sepsis and Septic Shock. Due to space limitations on the screen, the recommendations cannot always be reproduced in the full detail available in the printed and on-line guidelines. The SSC Sepsis Protocol is not a diagnostic or therapeutic tool and is not intended to replace the competent judgment of a clinician.

The SSC Sepsis Protocol consists of two separate consecutive phases:

Severe Sepsis Screening - measurement values and patient status are compared to the Severe Sepsis Screening criteria. When these criteria have been met, the clinician confirms the presence of infection and sepsis-related organ dysfunction and can authorize entering the Sepsis Resuscitation Bundle.

Sepsis Resuscitation Bundle - the recommendations for sepsis resuscitation are listed and can be checked off as they are implemented. After achievement of all the sepsis resuscitation goals, or at the latest after 6 hours, the Sepsis Resuscitation Bundle is completed.

The SSC Sepsis protocol may have been configured, to customize it for the specific treatment measures used in your facility. This can include changes to limits for measured or manually entered values, changes to the Severe Sepsis Screening criteria, and changes to the recommendations in the Sepsis Resuscitation Bundle. If configuration changes have been made, your screens may not exactly match the screens shown here.

Depending on the option your monitor has, it may be that only the Severe Sepsis Screening phase is implemented. If, at the end of this phase sepsis has been confirmed, and the patient is transferred for treatment in the resuscitation and management phases, you can transfer the current state, the settings and

the log from the SSC Sepsis Protocol in the Multi-Measurement Module to another monitor with the full version of the SSC Sepsis Protocol. The transfer of data and settings must be enabled in Configuration mode.

WARNING

Always consider the specific clinical context for your patient, before following SSC Sepsis Protocol treatment recommendations.

To check the version of the Guidelines and Bundle definitions on the monitor,

- Select **Main Setup** then **Revision** then **ProtocolWatch** followed by **SSC Sepsis**

Orientation On The Screen

At the top of each window there is an orientation line showing the phases available on your monitor, with the currently active phase highlighted.



You can also place the ProtocolWatch symbol, together with the currently active phase, on the main screen, in one of the numeric positions. This allows you to see at a glance which phase is currently active, even when no SSC Sepsis Protocol window is currently displayed.

If you need to enter data or perform an action in an SSC Sepsis Protocol window, the symbol will turn into a SmartKey.



Transferring Patients and Moving Manually Between Phases

If a patient has already been diagnosed as having severe sepsis before connecting them to the monitor, you can select **Main Setup** then **ProtocolWatch** followed by **Manual Transition** to go directly to the Sepsis Resuscitation Bundle to monitor treatment.

If a patient has been screened on arrival, for example in the emergency department, then transferred to Intensive Care when Sepsis is confirmed, the current state, the settings and the log from the SSC Sepsis Protocol will be transferred with the Multi-Measurement Module to the new monitor. Should it be necessary, you can select the phase at the new monitor manually with **Main Setup** then **ProtocolWatch** followed by **Manual Transition**. The transfer of data and settings must be enabled in Configuration mode.

CAUTION

It is not possible to transfer SSC Sepsis Protocol data from a monitor with release F.0 software to another monitor with release G.0 software or above, and vice versa.

Suspending the Protocol for 24 Hours

To suspend the protocol for 24 hours:

- 1 Select **Main Setup** then **ProtocolWatch** followed by **Suspend for 24 hours**.
- 2 Select **Confirm**.

The protocol will resume activity after 24 hours with Severe Sepsis Screening.

Severe Sepsis Screening

As soon as an adult patient is connected to the monitor, and heart rate or pulse is being measured, the protocol begins to observe heart rate, temperature and respiration rate values in the background. If temperature or respiration rate is not being measured continuously, a pop-up window appears at 4-hour intervals to ask for manually measured values. These values are all compared to the screening criteria: HR above 90, Temp above 38.3°C (100.9°F) or below 36.0°C (96.8°F), RR above 20.

If any one of the values fulfills the screening criteria, the first **Severe Sepsis Screening** window appears.

The measured value which has fulfilled the criteria is shown highlighted. There are check boxes for the infection signs and symptoms listed,

- if the monitor has measured values which meet the screening criteria, and
- for all signs and symptoms which cannot be measured by the monitor.

Check the box if you can confirm that this sign or symptom is **present** and **new**. If the patient is mechanically ventilated, the **Mechanically ventilated** box must be checked. If you have manually measured temperature or respiration rate, you can enter the values using the **Enter RR** and **Enter Temp** keys.

Select **Confirm** when the check boxes reflect the current patient status.

Select **Remind 15 min** if you want to delay filling out this screen. (When you enter the screen manually this key will be a **Cancel** key, as no action is required in this case.)

Changing Conditions

The window reappears if:

- a previously fulfilled criteria is again fulfilled
- a new HR or RR criteria is fulfilled,
- the HR or RR value which previously fulfilled the criteria now triggers a **** RR High**, **** HR High** alarm or a ***** xTachy xxx>yyy** alarm,
- after 8 hours (configurable to 12 hours) if at least one infection sign is still present.

Two Or More Infection Signs Or Symptoms Confirmed

If you have confirmed two or more infection signs in the first Severe Sepsis Screening window, a new pop-up window appears asking **Is the patient history suggestive of a new infection?**

If you select **Yes**, the next screen appears requesting a lactate measurement.

If you select **No**, the screening phase continues and the first Severe Sepsis Screening window reappears in the situations described in “[Changing Conditions](#)” above.

Lactate Measurement

To enter the Lactate value, select the **Enter Lact** key. If the value entered is > 4 mmol/l the check box is automatically checked.

Select **Confirm** when a value has been entered. What follows depends on the Lactate value:

- If **Lactate is > 4 mmol/l**: the value meets the criteria for severe sepsis and a window appears recommending authorized clinician review before entering the Sepsis Resuscitation Bundle.
- If **Lactate is ≤ 4 mmol/l**: a further window appears requiring your input to determine on the basis of blood pressure values whether the patient meets the criteria for severe sepsis.

Hypotension Evaluation

If the Lactate value was not above 4 mmol/l, the next window asks whether the patient has persistent hypotension.

The protocol defines Hypotension as:

- SBP < 90mmHg (12.0kPa), or
- MAP < 70mmHg (9.3kPa), or
- SBP decrease > 40mmHg (5.0kPa) below baseline.

You can see this definition in the window by selecting **Show Details**.

If the patient has persistent hypotension as defined, select **Yes**. This acknowledges that the patient meets the criteria for severe sepsis and a final window appears recommending authorized clinician review before entering the Sepsis Resuscitation Bundle.

If the patient does not have persistent hypotension, select **No**. After an hour a screen appears asking **Is the previously acknowledged infection still present?**

If you select **Yes**, the window for the Lactate measurement will reappear. If you select **No**, screening continues - comparing heart rate, temperature and respiration rate values against the screening criteria.

Authorized Clinician Review

To review the protocol, select **Protocol Log**. You can also print out the log to document the screening phase.

Select **Confirm** to complete the screening phase and, if you have the appropriate monitor option, continue to the Sepsis Resuscitation Bundle phase.

Sepsis Resuscitation Bundle

The treatment recommendations from the Sepsis Resuscitation Bundle are presented and the implementation of the recommendations is monitored.

When the Sepsis Resuscitation Bundle phase begins, the **ProtocolWatch** Screen automatically appears on the monitor (if configured and available on the monitor).

The lower area of the screen contains:

- a reminder list of the treatment recommendations - recommendations which have been fulfilled are shown in gray, overdue recommendations are shown in orange
- a timer showing the time already passed in this phase
- three horizon trends for MAP, CVP and ScvO₂ or SvO₂, if these measured values are available
- a list of the latest manually entered values - if you select this list you will open the **Manual Entry Log** window where the last 24 manually entered values are shown for reference

If ScvO₂ or SvO₂ and CVP are not being continuously measured, a pop-up window appears at hourly intervals to ask for a manually measured value.

Monitoring the Sepsis Resuscitation Bundle Recommendations

If the **ProtocolWatch** Screen is displayed, select the lower area to display the **Sepsis Resuscitation Bundle** window. If you do not have the **ProtocolWatch** Screen displayed, the **Sepsis Resuscitation Bundle** window appears automatically once an hour.

The first three recommendations are to be completed within three hours:

- Select the **Enter Lact** key to enter a lactate value. When you have entered a value, or if a lactate value had previously been entered, the box is checked.
- Check the **Take Blood Cultures** box when you have taken blood cultures.
- Check the **Administer Intravenous Antibiotics** box when you have started broad-spectrum antibiotic therapy.

The remaining recommendations are to be completed within 6 hours:

- If MAP, ScvO₂/SvO₂ and CVP are available as continuous measurements on the monitor, the values are automatically compared to the Sepsis Resuscitation Bundle criteria. A box is checked when the corresponding recommendation has been fulfilled.

Depending on your configuration, continuously measured CVP values may be disregarded if they exceed a set limit. Whether this is so, and which limit is applied, is set in the monitor's Configuration mode.

- If ScvO₂/SvO₂ or CVP are not available as continuous measurements on the monitor, you can measure them manually and enter the values using the **Enter ScvO₂** and **Enter CVP** keys. The box is checked automatically if the value fulfills the recommendation.
- Select the **Enter Lact** key to enter a new lactate value. When you have entered a value, the box is checked.

If MAP, ScvO₂/SvO₂ and CVP are neither measured continuously nor have had values entered manually, the checkboxes will be made available to be checked manually. This will be at the earliest after 4 hours to ensure that these values are achieved and maintained mid-term. Check these boxes if the recommendation has been fulfilled.

To see more details about the recommendations, select the **Show Details** key.

Select **Confirm** when the check boxes reflect the current treatment status.

Checking The Sepsis Resuscitation Bundle Window

During the Sepsis Resuscitation Bundle you can open the **Sepsis Resuscitation Bundle** window at any time to check the status or to make entries. The recommendations are shown as follows:

- Recommendations which are not yet fulfilled are shown in black. They also appear in the list on the lower area of the **ProtocolWatch** Screen.
- Recommendations which are overdue are shown in orange.
- Recommendations which have been fulfilled and confirmed are shown in gray. They no longer appear in the list on the lower area of the **ProtocolWatch** Screen.

Ending The Sepsis Resuscitation Bundle

The Sepsis Resuscitation Bundle normally ends after 24 hours, as documented by the bundle timer on the **ProtocolWatch** screen. You are asked to confirm with the **Yes** key that routine monitoring should now resume. By selecting **No** you can extend the Sepsis Resuscitation Bundle phase by an additional 6 hours.

After completion of the Sepsis Resuscitation Bundle a sepsis standby phase begins which allows time for further patient stabilization and recovery. During this phase Severe Sepsis Screening is suspended. The standby phase is by default 7 days but the length can be adjusted in Configuration Mode.

Viewing and Printing the Protocol Log

The Protocol Log stores all user interactions, alarms and phase transitions while the SSC Sepsis Protocol is running.

To view the Log select **Main Setup** then **ProtocolWatch** followed by **Protocol Log**

You can choose between three different views of the Protocol Log:

- **Summary View** - a short form which does not include when the windows were triggered
- **Full View** - a complete log of all user interactions, alarms and phase transitions
- **Phase View** - you can view log entries for one phase by selecting that phase on the orientation line

When the Log consists of several pages, you can move through the pages with the **Previous Page** and **Next Page** keys.

To start a Protocol Log printout, select **Print**.

The log is cleared whenever a patient is discharged.

Always Discharge Patients

It is essential that patients are discharged when monitoring ends. As a reminder, the monitor can be configured to display a pop-up window when the monitor has been switched off, in Standby mode, or not monitoring basic vitals for a certain time. The window asks whether a new patient is being monitored and offers a pop-up key to discharge the previous patient if this is the case. The window must be configured in Configuration Mode.

When the previous patient is discharged, this clears the protocol log, resets the timers and deletes manually entered measurement values.

Recording

There are two ways to record data using your monitor, depending on your model. If a paper-strip recorder is available, you can make paper recordings, selecting from a variety of recording types.

If no paper-strip recorder is available, or if you want to record data in electronic form, you can use electronic strip recording.

See and “[Electronic Strip Recording](#)” on page 394 for further details.

Paper-Strip Recording

The M1116B/C plug-in recorders record numerics for all active measurements and up to three waveforms. You can use them for local recording mounted in the monitor's Module Rack.

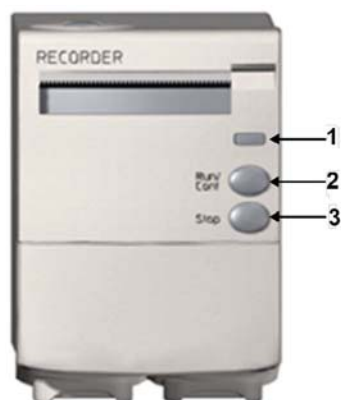

M1116B



- 1 Continue LED - lights if a continuous recording is ongoing
- 2 RUN/CONT key - starts a delayed recording, extends the current recording or makes the current recording continuous
- 3 STOP key - stops the current recording

M1116C



- 1 Continue LED () - lights if a continuous recording is ongoing.
- 2 Run/Cont key () - starts a delayed recording, extends the current recording or makes the recording continuous.
- 3 Stop key () - stops the current recording.
- 4 Door latch.

Central Recording

For central recording from the bedside, your monitor must be connected via a network to an Information Center. You can use either the M1116B/C or 862120 2-Channel Recorder or the standalone M3160A 4-Channel Recorder. Recordings made on the M3160A may look slightly different to those described here. See the documentation supplied with the Information Center for information on the 4-Channel Recorder.

Starting and Stopping Recordings

The recordings pop-up keys let you start and stop recordings. Select the **Recor- dings** SmartKey to call up the line of pop-up keys. Scroll right or left to see any pop-up keys not displayed.

The selection of pop-up keys available depends on the monitor you are using.

Delayed Recordng	Vital Signs
RT A Recordng	Alarm Limits
RT B Recordng	ST Segments
RT C Recordng	STE Segments
Select Waves	ECG QT
HiRes Recordng	Setup Recordng
All ECG Waves	Stop All Recordng

Quickstarting Recordings

To quickstart any type of recording using a pre-configured recordings template,

- Select the **Recor- dings** SmartKey and then select the pop-up key of the recording type you want to start.

Alternatively, you can

- Select the **Main Setup** SmartKey, select **Recordings**, then select the recording type.

To quickstart a delayed recording,

- Select the SmartKey **Delayed Record** to immediately start a delayed recording.

You can also start a delayed recording by pressing the Run/Cont key on the recorder module.

Extending Recordings

Timed (non-continuous) recordings stop when their runtime is over. Continuous recordings continue until stopped manually or by an INOP condition.

- To extend an ongoing recording by its runtime, reselect its **Start** pop-up key once.
- To make an ongoing recording continuous, reselect its **Start** pop-up key twice within 5 seconds.

You can also make an ongoing recording continuous by pressing the Run/Cont key on the recorder module.

Stopping Recordings

Recordings stop automatically when the preset runtime is over, when the recorder runs out of paper, when you open the recorder door or when the recorder has an INOP condition.

- To manually stop a recording, select the **Recor- dings** SmartKey and then select the pop-up key **Stop All Recordng**.

You can also stop a recording by pressing the Stop key on the recorder module.

Recording Without a Template

To record without a pre-configured template, selecting the waves you require,

- 1 *Either:* Select the **Recordings** SmartKey then select the pop-up key **Select Waves**.
Or: Select the SmartKey **Record Waves**.
- 2 Use the pop-up keys to choose up to three measurement waves to be printed on the recording. If you want fewer than three waves on the recording, select the waves you want then select the **Continue** pop-up key.
- 3 Select one of the recording speed pop-up keys to set the required recording speed.
- 4 Select the **Start** pop-up key to start the recording.

Select Waves recordings use default values for any recorder settings not defined: runtime is continuous, overlapping is set to non-overlapping.

Overview of Recording Types and Settings

The different types of recording have different characteristics, some are fixed and others can be set up in recording templates.

Fixed characteristics include:

- All recordings except alarm recordings are started manually. Alarm recordings are started automatically, triggered by defined alarm conditions.
- All recordings stop automatically, except **Realtime** and **HiRes Recording** when they have been set up as **Continuous** recordings. **Continuous** recordings must be stopped manually.
- **Realtime** recordings and **All ECG Waves** recordings include data from the time you start the recording, onwards. All other recordings are delayed recordings and include data from a point in time before you started the recording. The delay time defines the starting point of the recording.
- Recordings from a procedure or special context are started using the pop-up keys in the window. The settings for these recordings are defined by the context.

The table lists setting choices for recordings started locally. For details on recordings made on the central recorder, see your Information Center Instructions for Use.

Recording Type	Destination	Number of waves	Speed	Runtime	Delay time
Delayed	local or central recorder or print database (Strip Report)	up to 3, with or without overlap	50, 25, 12.5, 6.25, 2.5 mm/sec	15, 20, 25, 30 sec	10, 15 sec
Alarm	local recorder or print database (Strip Report)	up to 3, with or without overlap	50, 25, 12.5, 6.25, 2.5 mm/sec	15, 20, 25, 30 sec	10, 15 sec
Realtime	local or central recorder	up to 3, with or without overlap	50, 25, 12.5, 6.25, 2.5 mm/sec	6, 8, 10, 15 sec or continuous	none
All ECG Waves	local recorder	all ECG waves currently monitored and available, no overlap	25 mm/sec	4 sec per wave	none
Hi-Res Trend	local recorder	up to 3 high-resolution trend waves (beat-to-beat), with or without overlap	1, 2, 2.5, 3, 6 cm/min	10 min, or continuous	6, 5, 4, 3, 2, 1 min

All ECG Waves Recordings

An **All ECG Waves** recording shows a 4 second recording of each lead with a calibration bar preceding each ECG lead. All available leads are recorded sequentially in the standardized lead order. The recording is realtime, that is, the information recorded is not simultaneous.

Creating and Changing Recordings Templates

To save you defining recording settings each time you start a recording, you can create templates for commonly-used types of recordings in the **Setup Recording** menu. You can create templates for one delayed recording, one alarm recording, three realtime recordings, and one high resolution recording. **All ECG Waves** recordings do not need to be configured, they always use the same format.

Changing recordings templates changes the settings that will be used each time a recording of this name is triggered.

- 1 Select the **Main Setup** permanent key to call up the **Main Setup** menu.
- 2 Select **Recordings** to enter the **Setup Recording** menu.
- 3 Select the name of the template you want to create or change. Each recording name is linked to a recording type, delayed, alarm, realtime, and hi-res trends. Recording names can be changed in the monitor's Configuration Mode.
- 4 Design the template by selecting each menu item and entering the information for the template.
 - **Recorder:** choose which recorder the recording will print to (**Local**, **Strip Report**, **Central 2–Ch**, or **Central 4–Ch** recorder). For alarm recordings, only the **Local** or **Strip Report** recorder can be selected. Alarm recordings on the central recorders must be set up at the Information Center.
 - **Channel 1, Channel 2, etc.:** choose which waveform to record in each channel. If the wave assigned to a recording channel in a particular template is not available when a recording is triggered, the channel is left blank on the recording strip. The pop-up list of available (currently monitored) waves differs according to the recording type:

- Realtime, delayed and alarm recordings: the list shows all the currently available waves.
- High-resolution recordings: the list shows all the available high-resolution waves.

In addition to the currently available waves, you can choose from several other settings which make an automatic allocation when the recording starts:

- **Alarm Par** will always record the measurement in alarm in the chosen recorder channel
- **Primary Lead** will always record the current primary lead in the chosen recorder channel
- **SecondaryLead** will always record the current secondary lead in the chosen recorder channel
- **Any Agent** will always record the currently selected anesthetic agent.

For high-resolution recordings only the **Any Agent** setting is available.

- **Overlap:** define whether the recorded waveforms will be printed overlapping or beside each other.
- **Speed:** choose the recording print speed.
- **Delay Time:** Delayed recordings start documenting on the recorder strip from a pre-set time before the recording is started. This interval is called the "Delay Time" and can be set as specified in [“Overview of Recording Types and Settings” on page 389](#). This setting can only be changed in Configuration Mode.
- **Run Time:** see how long this type of recording is configured to run. This setting can only be changed in Configuration Mode. Continuous recordings run indefinitely.

Central Config: if available in the **General** menu, select this setting to use the recording settings made for the centrally-connected recorder.

Changing ECG Wave Gain

The **ECG Gain** setting in the **General Recording Setup** window defines how every recorded ECG wave, irrespective of template or recording type, will appear on the recorder strip. This does not affect the displayed ECG wave, or printed ECG reports.

To change the ECG gain setting for recordings,

- 1 In the **Setup Recording** menu select **General**.
- 2 Select **ECG Gain**.
- 3 Select the required setting:
 - **Auto**: the wave recording will use the same scale as the ECG wave on the monitor screen
 - **5 mm/mV, 10 mm/mV, 20 mm/mV**: the wave recording will use a scale of 5, 10, or 20 millimeters per millivolt.

Recording Priorities

Manually-started recordings have priority over automatically-started recordings. If an automatically-triggered alarm recording is running, and a realtime or delayed recording is manually started, the alarm recording is stopped and the manually-requested recording is started.

More recent manually-started recordings have priority over older manually-started recordings. If a manually-started recording is running, and another manually-started recording is triggered, then the older recording is stopped and the more recent manually-started recording is started.

Alarm recordings are prioritized according to alarm priority. If an alarm recording triggered by a yellow alarm is running and a new alarm recording is triggered by a red alarm, the yellow alarm recording is stopped and the red alarm recording is started.

Recording Strip

The information printed on the recording strip includes the patient name and MRN, bed number, date and time of recording, recording speed, and (except when the information is printed above the waves) recording code. Active alarm and INOP messages as well as numerics for all currently monitored measurements are also printed.

Recording strip annotations are printed at the beginning of the recording strip, either before or above the waves depending on the configuration. The annotations are updated at regular intervals, every 15 minutes for recordings made at speeds lower than 6.25 mm/s, and every 60 seconds for recordings made at speeds greater or equal to 6.25 mm/s. When annotations are configured to appear above the wave, it may not be possible to print them all when the runtime of the recording is too short.

Recording Strip Code

The recording strip code printed in the first line of the initial annotation has up to seven characters, specifying recording type, operating mode, application area, patient category, and delay time, if applicable. It is only included when annotations are configured to appear before the waves.

	Code	Meaning
Recording type	90	Realtime
	8A	Delayed
	0B	Alarm
	91	Context (Procedures)
Operating mode	M	Monitoring
	D	Demo
	C	Configuration
	S	Service
Application area	I	ICU
	O	OR
	C	CCU
	N	NICU
Patient category	A	Adult
	P	Pediatric
	N	Neonatal

Recorded Waveforms

A selection of up to three waveforms is recorded, marked with wave labels and wave scale information. Wave scale information can be in the form of a calibration bar, like the 1 mV calibration bar for ECG, or calibration steps before the waveform starts.

Maintaining Recording Strips

Recording ink sometimes fades when covered with transparent tape. Avoid covering any part of a recording that is clinically relevant (annotation or waveforms) when taping a recording strip to a patient record or other patient documentation.

Reloading Paper

CAUTION

The different recorder models require different paper types:

- For M1116B use 40477A or 40477B.
 - For M1116C use M4816A or M4817A.
-

M1116B

- 1 Use the latch on the right side of the recorder door to pull the door open.
- 2 Remove the empty core.
- 3 Insert a new roll so that it fits snugly into its housing and the paper end is feeding from the top. Recommended paper: 40477A and 40477B.
- 4 Pull out some paper and fold along the front edge at a 45° angle. This makes it easier to feed the paper under the roller as shown.
- 5 Feed the paper through and pull some paper out from the top of the roller.
- 6 Close the recorder door.
- 7 To test if paper is loaded correctly, start a recording. If no printing appears, paper may be loaded backwards. Try reloading the paper.

M1116C

- 1 Press the latch on the right side of the recorder door to open the door.
- 2 Remove the empty core.
- 3 Insert a new roll and secure it in place on the paper holder. The paper feeds from the bottom of the roll and over the top of the recorder door.

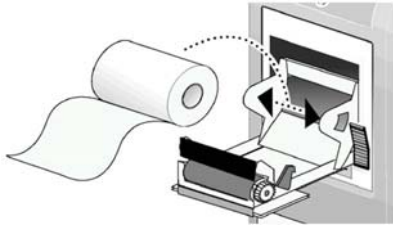

Recommended paper: M4816A and M4817A.

- 4 With at least one inch of paper extending beyond the edge of the door, swing the recorder door up and push it firmly closed.
- 5 To test if paper is loaded correctly, start a recording. If no printing appears, paper may be loaded backwards. Try reloading the paper.

CAUTION

When the recorder is disabled (for example, door open, or out of paper), any alarm recordings will be sent to the central station recorder, if there is one. If no recorder is available, alarm recordings may be lost during the time the recorder is disabled. The message **No alarm recording available** will be displayed. This message is not shown if **Printer** is configured as the alarm recording destination.

Recorder Status Messages

Recorder Status Messages	Explanation
For example: Local alarm recording running	The named recording is currently running.
No alarm recording available	No recorder available. Alarm recordings will be lost. Try configuring Printer as the alarm recording destination.

Recorder Status Messages	Explanation
Central Recorder out of paper Local Recorder out of paper	The named recorder is out of paper.
Central Recorder door open Local Recorder door open	The door of the specified recorder is open.
<Recorder Type> not supported	The M1116A recorder is not supported. Connect a M1116B/C plug-in recorder.

Electronic Strip Recording

Electronic strip recording allows alarm-triggered and manually started electronic strips to be captured in the monitor print database. They can then be reviewed on the monitor, and printed in the form of reports when a printer is available.

The strips can be sent to an Information Center* or to the XDS Printing Service that is part of the IntelliVue XDS Software. The reports can then be printed to a standard off-the-shelf printer and can also be stored as files on the Information Center or the PC hosting the XDS Printing Service.

* Not available with PHIC iX Release B and earlier

Setting up Electronic Strip Recordings

You can create a template for alarm-triggered electronic strip recordings and delayed electronic strip recordings as described in “[Creating and Changing Recordings Templates](#)” on page 390. For **Recorder**, you must select **Strip Report**. For all other menu items you can select the settings most appropriate for your requirements.

Starting an Electronic Strip Recording

When the templates have been set up (see “[Setting up Electronic Strip Recordings](#)” on page 394), recordings can be started. An alarm-triggered electronic strip recording starts automatically, when the corresponding alarm condition occurs.

To start a delayed electronic strip recording:

- 1 Select the **Recordings** SmartKey.
- 2 Select the **Delayed Recording** pop-up key.

Viewing Electronic Strips

- 1 In the **Reports** menu, select **Report List**.
- 2 In the list, select the electronic strip you want to see. You can identify electronic strips by **Strip** in the paper size column.
- 3 Select the **Review Report** key.

The electronic strip opens with the section of the wave from the time the report was triggered. You can scroll to see the rest of the strip, using the arrow keys or by sliding with a finger across the screen.

When you view an electronic strip, you also have the option to print it manually, in the form of a strip report:

- Select **Print** to print the currently displayed strip as a report on the default printer, or
- Select **Print To** to choose from a list of printers, if several are available.

When an electronic strip is printed out, it will be in the standard report page-format.

For automatic printing of electronic strips, see “[Setting up Printing and Storage for Electronic Strips](#)” on page 395.

Setting up Printing and Storage for Electronic Strips

The electronic strips captured in the database remain there until they are printed in the form of a report, even after patient discharge. You can make settings to define how electronic strips are printed and whether they are stored.

- 1 In the **Reports** menu select **Print Strip Rep.**
- 2 Select one of the following settings:
 - **Auto+Delete** - Strips will be automatically printed and then deleted from the monitor's print database.
 - **Auto + Keep** - Strips will be automatically printed and will remain in the monitor's print database for viewing.
 - **Host+Delete** - Strips stored on the host monitor will be automatically printed and then deleted from the monitor's print database. Strips stored on an X2/X3 in companion mode must be printed manually.
 - **Host + Keep** - Strips stored on the host monitor will be automatically printed and will remain in the monitor's print database for viewing. Strips stored on an X2/X3 in companion mode must be printed manually.
 - **Manual** - No strips will be automatically printed. You can print individual strips manually by selecting the strip report in the **Report List** and selecting the **Print** pop-up key. After printing, the strips are deleted from the monitor print database.

The **Auto + Keep** and **Host + Keep** settings are only available when the report capability is set to **Enhanced** in Configuration mode.

CAUTION

Be aware that the **Auto + Keep** and **Host + Keep** settings can lead to the print database quickly becoming full, depending on your report frequency. The maximum number of reports that can be stored in the database varies depending on the database configuration and the size of the reports. When the print database is full, no more reports can be generated that are set up to print to the database. This includes alarm-triggered electronic strip recordings. In this case, print or delete reports to make space available in the database.

Depending on the settings made at the Information Center* or the XDS Print Server, strips may also be stored there, as well as printed.

* Not available with PIIC iX Release B and earlier

Generating Patient Reports

A variety of different reports can be generated, for specific measurements, trends, events and procedures.

Depending on availability, reports can be sent:

- to a locally connected printer
- to an Information Center, for printing, storage and transmission to hospital systems
- to an IntelliVue XDS Printing Service, for printing and storage
- to the monitor print database

Reports sent to an Information Center, or to a PC hosting the IntelliVue XDS Printing Service, are encrypted to protect patient privacy. If no **Lifetime ID** or **Encounter ID** is entered for the patient, it may not be possible to assign the reports to the patient in an EMR system.

Print jobs in the print database are **not deleted** after a patient discharge. A new patient can be admitted and their reports are saved in addition to the previous reports. Always admit your patient so that reports can be clearly assigned to a patient.

When an X2/X3 is connected to a host monitor, reports requested or stored on the X2/X3 can be printed via the host monitor. Reports requested on the X2/X3 when connected to a host monitor will not show any patient alarms or INOPs. In order to see alarms, reports should be requested on the host monitor.

Starting Reports

Patient reports can be started in one of three ways:

- by selecting **Main Setup** then **Reports** (or the **Print Reports** SmartKey) and then selecting the report name in the top half of the **Reports** menu. Report names are shown for all reports that have been correctly set up.
- in the context of the window or menu for the measurement or function addressed in the report, for example, in the **Graphical Trends** window. See “Starting the Different Types of Report” on page 397 for details.
- with a SmartKey, for those reports that have their own SmartKey, such as **Realtime Report**, **Graph Trends**, **Vital Signs**, **ECG Report A**, **ECG Report B**.

For most reports different ways are possible and you can choose the most convenient.

Data from the time of the print request is included in the report, even if the print job is delayed in the printer queue.

Starting the Different Types of Report

Report types	Report contents	How to start printing reports
Vital Signs Report	Depends on selected trend group, data resolution, and period.	In the Vital Signs window, select Print/ Record , then select Print .
Graphic Trends Report		In the Graphical Trends window, select Print .

29 Generating Patient Reports

Report types	Report contents	How to start printing reports
Events Reports	Event Episode	In the Event Episode or Event Review window, select the pop-up key Print/ Record , then select Print Review or Print Episode .
	Graphic or tabular Event Review	
EEG Report	EEG Waves, numerics, CSAs, montage information and impedance values	In the Setup EEG menu, select Print Report .
aEEG Report	Up to four channels of aEEG trend data	In the Setup EEG window, select Print Report .
ECG Reports	Depends on format selected.	Select the ECG Report A or ECG Report B SmartKeys, if configured, or the Print Reports SmartKey followed by ECG Report A or ECG Report B .
12-Lead Report	Captured ECG waves, measurement values, ST Map (optional) and analysis results from the Information Center (PIC iX only)	In an active 12-Lead application window, select the Print Report pop-up key.
ST Map Report	ST data in a transversal and/or horizontal multi-axis diagram	In the ST Map (Current) or ST Map (Trend) window, select Print .
STE Map Report	ST elevation data in the form of the STE map and STE snippets	In the STE Map window, select Print .
ECG QT Report	QT waveforms with Q and T points, QT numerics and supplemental information for the current and baseline QT measurement	In the QT View window, select Print QT .
Cardiac Output Report	Trial curves and numerics	In the Cardiac Output (Right Heart) or Cardiac Output (Transpulmonary) window, select the pop-up key Print/ Record .
Wedge Report	Wedge numerics and reference wave	In the Wedge window, select the Print Wedge pop-up key.
Histogram Report	Depending on where the report is triggered, it will show the currently displayed histogram or the histogram set up as default	In the window displaying the histogram, select Print .
Protocol Watch Report	SSC Sepsis protocol log in one of three views as described in “Viewing and Printing the Protocol Log” on page 385	In any Protocol Watch window, select Protocol Log and then either Summary View , Full View , or Phase View .
Calculations Report	Hemodynamic, Oxygenation, or Ventilation Review	In the Calculations windows, select the Print/ Record pop-up key.
Drug Calculator Report	Titration Table	In the Titration Table window, select the Print Titr.Tbl pop-up key.
	Drip Table	In the Drip Table window, select the Print Drip Tbl pop-up key.
Alarm Limits Report	Graphic and numeric report of all current alarm limits	In the Alarm Limits window, select Print Limits .
Realtime Reports, including oxyCRG Reports	Patient data and numerics, and either: all displayed waves OR all measured waves OR all measured RT waves OR all measured HiRes waves, OR oxyCRG waves (RT waves: ECG Primary lead, Pleth, Resp; HiRes waves: btbHR, HiRes SpO ₂ , HiRes Resp)	Select the Realtime Report SmartKey, if configured.
Loops Report	Individual Loops diagram with timestamp, currently measured numerics	In the Loops window, select Print Loop .
Strip Report	The content of an electronic strip recording.	In the Report List , select the required Strip report and then select Print .
Central Report A/B/C	These are reports configured at the Information Center that can be started directly from the monitor.	In the Main Setup select Reports then Central Report A , Central Report B or Central Report C .

Canceling Reports

To cancel the report that is currently printing, in the **Reports** menu, select **Delete Report** to stop the current print job.

To cancel all queued reports, in the **Reports** menu, select **Delete All Repts.**

You can also cancel individual reports in the **Report List**, see “[Checking Report Status and Printing Manually](#)” on page 399.

Checking Report Status and Printing Manually

A list of all print requests which are waiting, printing or stored can be viewed in the **Report List**. To view the list, in the **Reports** menu, select **Report List**, or use the **Report List** SmartKey, if configured.

The following information is displayed for each print request:

- Report title
- Patient name, or Lifetime ID/Encounter ID when no patient name is available (except for system reports)
- Request date and time
- Report paper format
- Job status: **Preparing, Printing, Waiting, In Database, In Companion, Retry, Cancelling, Unsupported, Error.**

Additionally a symbol indicates the report status:



Unreviewed



Reviewed



Printed

More than one symbol can appear, for example, to indicate "reviewed" and "printed". Some symbols appear only when your monitor has optional functionality.

With the **Filter** key, you can reduce the number of reports visible by selecting a certain category to be shown, for example, **Unprinted Rep.** to show all reports not yet printed.

Reports shown in black will be printed automatically when a matching printer is available. Reports shown in gray must be printed manually, see “[Printing Manually](#)” on page 400.

Individual reports can be deleted from the list with the **Delete** key, and all reports with the **Delete All Repts** key.

CAUTION

The **Report List** includes privacy information, in the form of the patient name with the related report title and date. It is advisable to provide controlled access to this data to ensure confidentiality.

If an X2/X3 is connected to a host monitor, all print requests which are stored in the print database of the X2/X3 are shown "grayed out" in the **Report List** on the X2/X3. These reports can only be accessed at the host and cannot be printed or deleted at the X2/X3.

Printing Manually

Any reports shown in gray must be printed manually, if a printout is required:

- 1 In the **Report List**, select the required report.
- 2 Select **Print**, to print to the default printer, or **Print To** to select a printer when more than one is available.

Selecting **Print All** will send all reports to the default printer.

The **Print** and **Print All** keys will not be available, if the database setting for all reports is **Auto+Delete** (see “Setting Up Printing and Storage for the Print Database” on page 404).

You can also print reports from the review window, see .

Setting Up Reports

In most cases, the standard reports used in your facility have been configured to match your requirements. If you need to make changes to the report setup for your patient, you can do that in the reports setup menus described in the following sections.

The content you define in the individual setup menus will be used in all reports of this type: for example, if you set a print speed of 50 mm/sec in the **ECG Reports** menu, every ECG report will be printed at this speed, irrespective of format.

The lead sequence for ECG reports, and the Auto reports settings, must be defined in Configuration Mode.

As the content of context-linked reports, such as Cardiac Output, Calculations, and Wedge, is defined by the content of the procedure window these reports do not need to be set up, however a target printer can be set up in the **Setup Reports** menu.

General Report Setup

Select **Main Setup, Reports**, then **Setup Reports** to enter the **Setup Reports** menu.

- 1 Select **Report** and then select the report you want to set up.
- 2 For the following reports, select **Report Type**, and then select the reports template you want to use.

Realtime Reports:

- **VisibleWaves:** all waves currently visible, in the order they appear on the screen.
- **All Waves:** all measured waves.
- **RT Waves:** all currently measured realtime waves, according to the monitor's priority list.
- **HiRes Waves:** all measured HiRes waves.
- **OxyCRG Waves:** the OxyCRG/Neonatal Event Review waves.

ECG reports:

- **ECG3x4, ECG6x2, ECG12x1, ECG4x2, ECG8x1, ECG12x1 (2P)**

Event Review Reports:

- **Review:** event review report for the event group with the most current episode
- **EventRev All:** summary event review report of all patient events
- **CAR Report:** the last CAR Seat report

All other reports have a fixed template.

- 3 Select **Report Size** to set the paper size to be used for the report: **Unspecified** to use the default size for the template chosen, **Universal, A4, Letter, LrgUniversal, A3, or Ledger**. The list of available sizes depends on the report type selected.
- 4 Select **Orientation** to set the orientation of the report printout: **Unspecified** to use the default size for the template chosen, **Landscape** or **Portrait**.
- 5 Select **Target Device** and choose which printer the print job will be sent to: **Unspecified** to use the default printer, or choose from the list of printer names defined at the Information Center or in the monitor's Configuration Mode (for example, **Remote 1** or **Database**).

Some settings may not be available in this menu for reports that can only be started in a special window.

Setting Up ECG Reports

The settings you choose in the **ECG Reports** menu apply for all ECG-A and ECG-B reports printed. To set up ECG Reports,

- 1 Select **Main Setup, Reports**, then **ECG Reports**. Note the report layout configured for your monitor, either **Internat** or **Cabrera**. This setting is inactive ("grayed-out") in Monitoring Mode and can only be changed in Configuration Mode.
- 2 Select **ECG Gain** and set the required ECG gain to define how ECG waves will appear on the ECG report printouts.
- 3 Select **Speed** and select the report print speed.
- 4 Select **Annotation** and switch to **On** if the printed ECG wave should be annotated with beat labels. See the "ECG, Arrhythmia, ST and QT Monitoring" chapter for a list of beat labels. Pace pulse marks are automatically printed beside the wave for paced patients.

Setting Up Vital Signs and Graphic Trend Reports

The settings you choose in the **Vital Signs Report** and **Graphical Trend Report** menus apply for all Vital Signs and Graphic Trend reports printed.

To set up Vital Signs and Graphic Trend reports,

Select **Main Setup, Reports**, then **Vital Signs Rep.** or **Graph Trend Rep.**.

- 1 Select **Trend Group** and select the group you want to print on the report. The groups available depend on your monitor's trend configuration.
- 2 Select **Period** and select the period of time for which trend data should be printed on the report. If **Automatic Period** is configured to **On**, all trend data for the current patient will be printed, irrespective which trend period is selected.
- 3 Select **Interval** (Vital Signs Reports only) and select the resolution of the trend data printed on the report.

Setting Up Auto Reports

Auto Reports print automatically when a specified trigger occurs. There are two types of Auto Reports: Scheduled Reports, which print at predefined intervals, and End Case Reports, which print when a patient is discharged using the End Case function. An Auto Report can be both a Scheduled Report and an End Case report.

To set up Auto Reports,

- 1 Select **Main Setup, Reports**, then **Auto Reports** and select the Auto Report you want to set up (A, B, C, or D).
- 2 Select **Report** and assign a report type to the Auto Report.
- 3 Select **End Case Report** and switch to **On** if you want the selected report to print automatically when you select **End Case** to discharge a patient.
Switch **End Case Report** to **Off** if the report is a Scheduled Report only.
- 4 Select **Scheduled Rep.** and toggle to **On** if you want the selected report to print at predefined intervals, starting at a predefined time of day. The start time you set applies for every following day. For example, if you set a start time of 07:00 and a repeat time of six hours, the first report will print at 07:00 every day, the next at 13:00 and so on.
 - To set the time of day at which you want the report to print every day: select **Start Hour** and **Start Minute** and select the required time from the pop-up list
 - To set the time interval in minutes between two scheduled reports: select **Rep. Freq. (h)** and **Rep. Freq. (min)** and select the time interval from the pop-up list.

If you are setting up an end case report, these settings will be inactive ("grayed-out").
Switch **Scheduled Rep.** to **Off** if the report is an End Case Report only.
- 5 Repeat the procedure for all Auto Reports you want to set up.
All Auto Reports or Scheduled Reports set to **On** print automatically at the predefined trigger.

Be aware that the monitor's memory for reports is limited. The number of reports that can be stored depends on the size of the reports and the size of the printing database; the maximum is 30 reports. If the memory is full, reports cannot be saved on the printing database and therefore cannot be printed.

If you set up regular scheduled reports, and you have long case durations, make sure that the print database is configured to **Medium** and plan to print reports at appropriate intervals in order to avoid losing information due to a full memory.

Setting Up CSA on EEG Reports

To set up CSA on EEG Reports,

- 1 Select **Main Setup, Reports**, then **CSA on EEG Rep.**.
- 2 Select **Buffer**, then select the buffer time.
- 3 Select **Trend SEF**, **Trend MDF**, and **Trend PPF**, and set them **On** or **Off**, as required.

Viewing Reports on the Screen

All reports stored in the print database of the monitor, or a connected X2/X3, can be reviewed on the monitor (with the appropriate monitor option).

To review a report on the monitor:

- 1 In the **Reports** menu, select **Report List**.
- 2 In the list, select the report you want to see.
- 3 Select the **Review Report** key.

Most reports will be displayed as a full-page report, in the same format as they are printed out. Only electronic strip reports are displayed differently - in the form of a recording strip. The electronic strip report opens with the section of the wave from the time the report was triggered. You can scroll to see the rest of the strip. When an electronic strip is printed out, it will be in the standard report page-format.

When a full-page report is displayed, the report title and trigger time are shown in the window title. You can zoom and scroll the report in the window, and navigate through the pages of the report.

In addition, the following pop-up keys are available:

Previous Report	Display the previous report in the report list.
Next Report	Display the next report in the report list.
Print	Print the currently displayed report on the default printer.
Print To	Print the currently displayed report on a printer you choose from the list of printers.
Delete Report	Delete the currently displayed report. The next report in the report list is then displayed.

Reports displayed using the **Review Report** functionality are not of diagnostic quality and are not intended for diagnostic use.

Setting Up Printing and Storage for the Print Database

Your monitor can be set up to automatically print reports from the print database when a printer is available. To set this up:

- 1 In the **Reports** menu select **Print Dbs Rep.**. The settings shown are for all reports except electronic strip reports; see “[Setting up Printing and Storage for Electronic Strips](#)” on page 395 for the electronic strip report settings.
- 2 Select one of the following settings:
 - **Auto+Delete** - Reports will be automatically printed and then deleted from the monitor's print database.
 - **Auto + Keep** - Reports will be automatically printed and will remain in the monitor's print database for viewing.
 - **Host+Delete** - Reports stored on the host monitor will be automatically printed and then deleted from the monitor's print database. Reports stored on an X2/X3 in companion mode must be printed manually.
 - **Host + Keep** - Reports stored on the host monitor will be automatically printed and will remain in the monitor's print database for viewing. Reports stored on an X2/X3 in companion mode must be printed manually.
 - **Manual** - No reports will be automatically printed. You can print individual reports manually by selecting the report in the **Report List** and selecting the **Print** pop-up key. After printing, the reports are deleted from the monitor print database.

The **Auto + Keep** and **Host + Keep** settings are only available when the report capability is set to **Enhanced** in Configuration mode.

CAUTION

Be aware that the **Auto + Keep** and **Host + Keep** settings can lead to the print database quickly becoming full, depending on your report frequency. The maximum number of reports that can be stored in the database varies depending on the database configuration and the size of the reports. When the print database is full, no more reports can be generated that are set up to print to the database. This includes automatic alarm-triggered reports. In this case, print or delete reports to make space available in the database.

Checking Printer Settings

The printer settings for your monitor are defined in Configuration Mode. The printer settings **Paper Size**, **Resolution**, **Color Support**, and **Duplex Option** for the active printer are visible but inactive (“grayed-out”) in the **Setup Printers** menu. When **Print Database** is selected as active printer only the **Paper Size** setting will be shown.

- To enter the **Setup Printers** menu, in the **Reports** menu, select **Setup Printers**.

Printer names for locally-connected printers can be defined in Configuration Mode. You can see whether a specified printer is centrally or locally connected in the **Setup Printers** menu under **Port**. If “Local” is included in the port name, e.g. **Local 2**, that indicates locally-connected printers, and “Remote”, e.g. **Remote 1**, indicates centrally-connected printers.

If you are using an IntelliVue XDS Printing Service, you may see XDS printers in the **Setup Printers** menu that also have “Local” or “Remote” in their name. Their names and settings can only be configured in the XDS Software. Refer to the IntelliVue XDS Software Installation and Configuration Guide for full details about the configuration possibilities.

Printing a Test Report

A test report can be printed in Configuration mode, refer to the Service Guide for more information.

Switching Printers On or Off for Reports

You can enable or disable printer status to switch individual printers on or off for report printouts.

- 1 In the **Setup Printers** menu, select **Printer** and then select the name of the device you want to switch on or off for Reports printing from the pop-up list.
- 2 Select **Printer Status** to switch between the settings **Enabled** and **Disabled**. If you set this to **Disabled**, no reports will be printed to the named printer.

If the monitor detects that no printer of a particular type is available, the **Printer Status** setting will automatically be set to **Disabled** and "grayed out".

Local printers from the IntelliVue XDS Printing Service are always enabled and cannot be disabled here.

Dashed Lines on Reports



If a section of a wave on a report is drawn with dashed lines, this tells you that a setting that affects the appearance of the wave on the screen was changed while the report was printing. For Realtime Reports and ECG reports, an additional annotation **Wave Settings Changed** is printed on the report.

For example, if you change the wave scale while a report is printing, the wave scale and wave size are changed immediately on the monitor screen and on the report. To indicate that the scale information printed at the beginning of the report no longer matches the currently used scale, the wave will be printed using dashed lines, starting from the moment the change took place.

Some examples of settings that cause dashed lines in reports if changed during printing are: Filter mode, ECG lead placement, wave scale, measurement unit, paced/non-paced setting, and measurement mode. Note that as ECG waves are drawn with a fixed gain on reports (either 10 mm/mV or 20 mm/mV), changing the ECG wave scale will not cause dashed-line reports.

To avoid dashed lines on reports, wait 15 seconds after changing a setting before you trigger a report.

Unavailable Printer: Re-routing Reports

If you send a report to be printed on a printer that is not available, for example, because it has run out of paper, this print job is suspended and stored in the monitor's memory.

If the target device of this print job was set to **Unspecified**, the monitor will periodically try to resend the print job to the first printer listed in the **Setup Printers** menu under **Printer** that is set to **Enabled** and that has paper of the correct size.

To allow the report to print, you must either solve the problem with the target printer, or re-route the print job to another printer with paper of the correct size. To re-route a print job,

- Enable the new target printer by selecting it in the **Setup Printers** menu and toggling to **Enabled**. As the monitor tries to send the report to the printers in the order they are listed, you must make sure that all the printers above the new target printer are disabled.

If the target device of the print job was set to a specific printer, re-routing is not possible.

Printer Status Messages

Printer Status Message	Possible causes and suggested action
Print job queued for <Printer Name>	The report has been placed in the queue for the named printer.
Print job could not be queued (insufficient resources) Print job could not be queued (queue is full) Print job could not be queued (no matching printer found)	The printer queue is full and the monitor cannot accept another report request. Wait until some more reports have been printed, then try again, OR A report has been triggered that uses a paper size unavailable with the target printer. Try another printer, if available, or change the paper size of the print request.
Canceling all print jobs	Delete All has been selected in the Reports menu, OR The Operating Mode has been changed from Monitoring Mode to Demonstration or Service Mode.
Canceling the active print job	The current report is being canceled as the result of a user request.
Deleted print jobs due to patient discharge	When a patient is discharged, all queued reports are canceled except those stored in the print database.
Canceling # print jobs due to monitor restart	The monitor has restarted and all report requests have been canceled except those stored in the print database. "#" is the number of reports canceled.
Printing failed: No report configured!	A report has been triggered which has not been correctly set up. Enter the setup menu for the report type to set up the report.
Printing on <Printer Name>...	A report is in progress, or the monitor is waiting for the central printer to accept the print job.
Printer <Printer Name> unavailable -> job suspended	The chosen device is unavailable. Check that the printer is properly connected and that paper is available. The requested report will start printing when the printer becomes available.
Print database full -> job suspended	The requested report does not fit into the print database. You can select another printer to print the report (see “Unavailable Printer: Re-routing Reports” on page 405). Alternatively you can delete another report from the Report List (using the Delete key) to create space for your report.
Job on <Printer Name> failed (data unavailable) Job on <Printer Name> failed (printer unavailable) Job on <Printer Name> failed (data requisition error)	A report cannot be started on the requested printer. One of three reasons is shown in the status message: <ul style="list-style-type: none"> • data unavailable - the connected X2/X3 has been removed before the data for the report was transferred. • printer unavailable - make sure the printer is plugged in, switched on, and has paper loaded. • data requisition error - an internal error has caused data required for the report to be unavailable, try starting the report again.
Print job on <Printer Name> done	The report has been printed.
This central supports only basic report capabilities	The report could not be sent to the Information Center because report capability is configured to Enhanced . This capability is not supported by the connected Information Center.
Print database nearly full	The print database is nearly full. Print or delete reports to increase the available space.
Print database full -> job suspended	The report just triggered does not fit into the print database. The print job is suspended until space is made available (by printing or deleting reports) or the print job is rerouted (see “Unavailable Printer: Re-routing Reports” on page 405).

Printer Status Message	Possible causes and suggested action
Print database full	The print database is full. Print or delete reports to increase the available space.
Unreviewed reports in print database	The print database contains one or more unreviewed reports. This status is only displayed, if the report capability is set to Enhanced .
Report review failed	The report cannot be displayed.

Sample Report Printouts

Each report header contains the patient's bed label, last name and first name, middle name (if there is enough space) the patient ID, the date and time, and the name of the report. The report footer contains the hospital label and page number, and the last page contains a note to mark the report end.

The monitor may be configured to leave a space on the top left or right of the report printout to enable you to stick a patient address label on it. This setting is called the **Addressograph** and it can only be changed in the monitor's Configuration Mode.

Alarm Limits Report

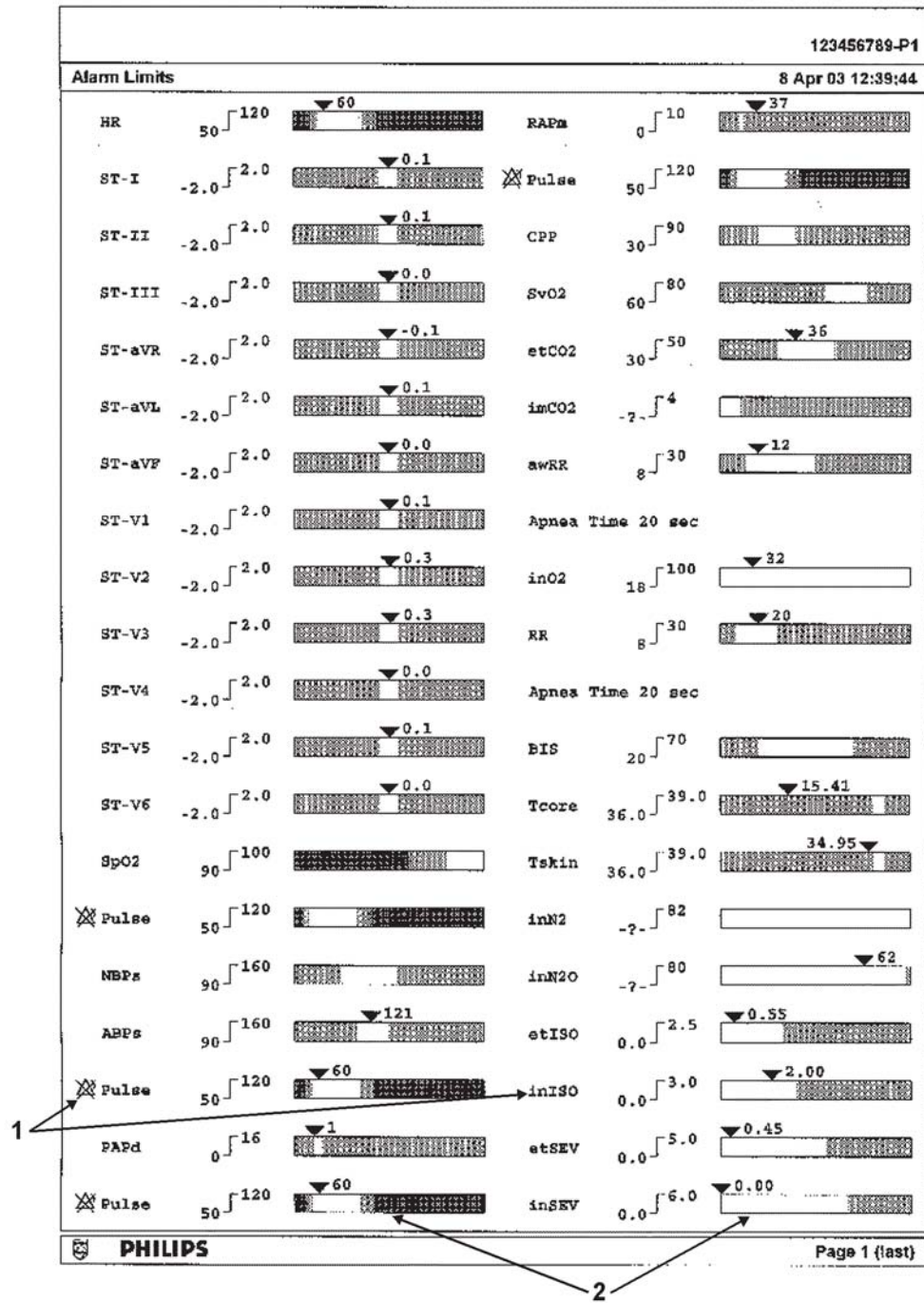

- 1 Measurement labels, with alarms off symbol where alarms are switched off
- 2 Graphic view of current alarm limits in relation to currently monitored measurement value

Realtime Report

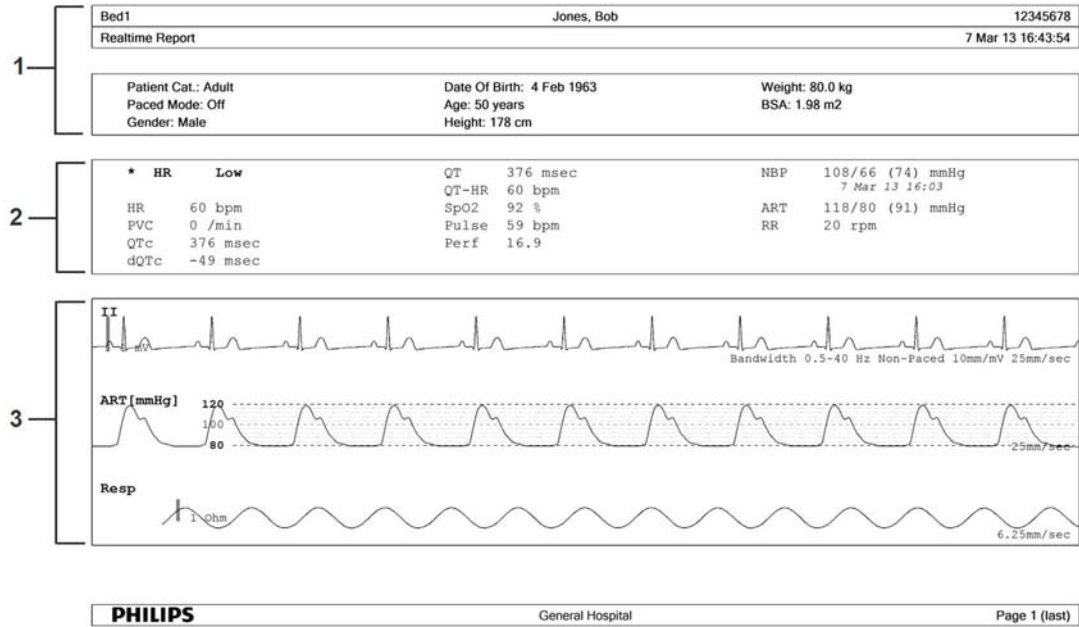

- 1 Patient demographic information, time stamp
- 2 Active Alarms and INOPs, followed by vital signs
- 3 Measurement waves section

Cardiac Output Report

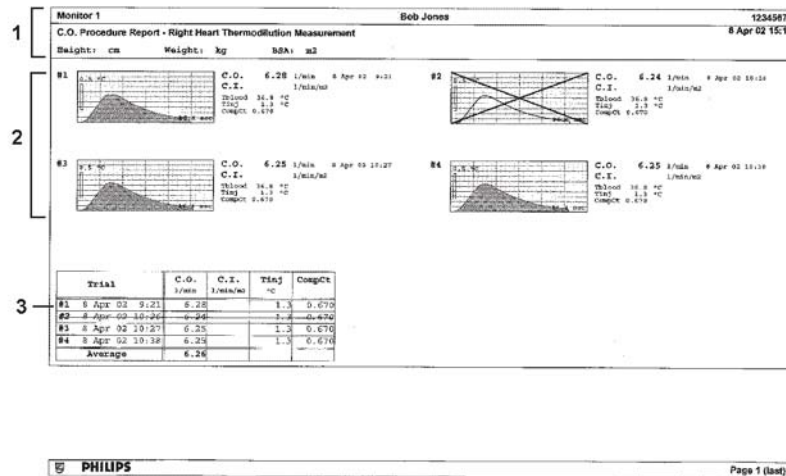

- 1 Patient information
- 2 Numbered trial curves
- 3 Trial information in tabular form

ECG Reports

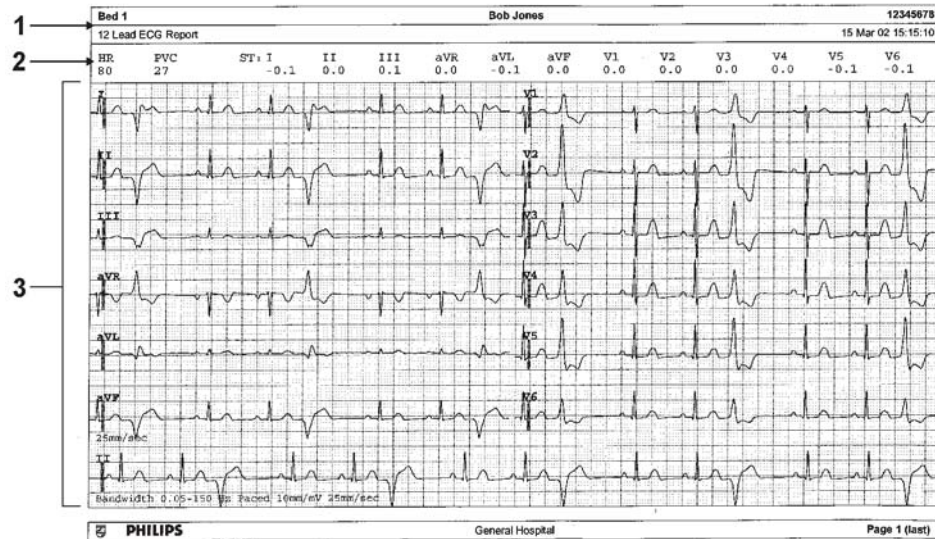

- 1 Patient information
- 2 Numeric block
- 3 Wave area

Below the header on ECG Reports, the numeric block shows the current HR, PVC, and ST values. The wave area shows the printed waves for all available ECG leads. A 1 mV calibration bar is printed at the beginning of each wave. With the 3X4, 6X2, and 2X4 formats, a rhythm stripe prints a longer section of the ECG wave from the primary ECG lead for ECG rhythm evaluation. The ECG signal bandwidth, the patient's paced status, the ECG gain, and the print speed are printed at the bottom of the wave area. Pace pulse marks are automatically printed beside the wave for paced patients. Beat labels can be set to print on the rhythm stripe. If no rhythm stripe is present, the beat labels will be printed on the primary lead. The 12X1 (2P) format prints the report over two pages.

ECG Report type	Available Formats	Available Paper Sizes
12-Lead ECG	3X4 landscape	A4, letter, A3, ledger
	6X2 landscape	A4, letter, A3, ledger
	12X1 portrait	A4 and letter only
	12X1 landscape	A4, letter, A3, ledger
	12X1 (2P) landscape	A4, letter (2 pages)
Multi-lead ECG	2X4 landscape	A4, letter, A3, ledger
	8X1 portrait	A4 and letter only
	8X1 landscape	A4, letter, A3, ledger

12-Lead ECG Report

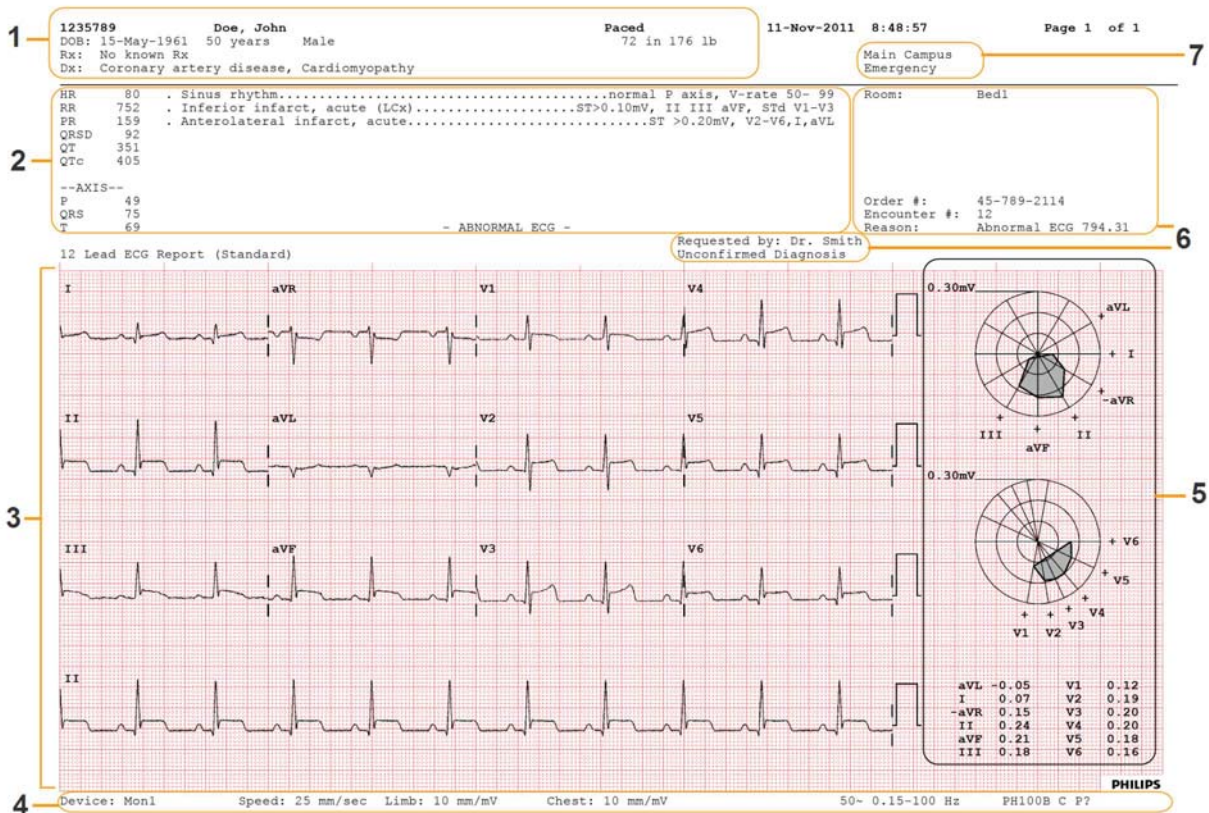

- 1 Patient data
- 2 Analysis data from the Information Center (PIC iX only)
- 3 12-Lead wave area
- 4 Data related to the wave presentation
- 5 ST Map with related ST numerics (optional)
- 6 Administrative data - including optional custom text fields
- 7 Hospital ID data - Institution, facility and department, if configured

Other Reports

See the sections on Trends and Calculations and the chapter on Event Surveillance for other example reports.

Using the Drug Calculator

Drug mixtures for intravenous (IV) drug infusions combine information on drug dose, rate, amount, volume, concentration, and standardized rate. The Drug Calculator helps you to manage infusions by calculating one of these values at a time.

Term	Definition	Units
Dose	total quantity of drug to be delivered to the patient over time	amount units per time or per kg/ time, if the drug is weight-dependent
Rate	volume of the mixture to be delivered to the patient over time	ml/hour
Amount	amount of drug to be added to diluent to make up a mixture	ng, mcg*, mg, g, mUnit, Unit, where g stands for gram
Volume	quantity of mixture of diluent and drug	ml
Concentration	ratio of the amount of drug to the solution volume	amount units per ml
Standardized Rate	1 ml volume of the mixture to be delivered to the patient per hour	ml/hr

*Be aware that your hospital may use either ' μg ' or 'mcg' as an abbreviation for microgram. These abbreviations are equivalent.

WARNING

Before you administer any drug, always check that the correct calculation units and patient category are selected. Consult your pharmacy if you have questions.

Decisions on the choice and dosage of drugs administered to patients must always be made by the physician in charge. The Drug Calculator performs calculations based on the values input during use, it does not check the plausibility of the calculations performed.

Accessing the Drug Calculator

To access the Drug Calculator, select **Main Setup** then **Calculations** followed by **Drug Calculator**, or select

the  **Drug Calc** SmartKey, if configured.

Performing Drug Calculations

Using the service Support Tool, a list of drugs can be configured for the monitor containing pre-defined dosage recommendations and unit settings. Selecting the arrow beside the drug name in the **Drug Calculator** window opens a list of configured drugs. Contact your pharmacist if you have any questions about the drugs in the list.

If **ANY DRUG** is the only entry in the list of drugs, no drugs have been pre-configured for your monitor. Drug calculations can be performed for non-specific drugs.

You must have a Support Tool to add additional drugs to the Drug Calculator.

About the Rule of Six

If the Rule of Six has been enabled for use with individual drugs in your Drug Calculator, you can use the formula in crisis situations to quickly calculate the amount of a drug needed to yield a target dose for continuous infusion for neonatal or pediatric patients (the drug amount is given in "mg", the patient weight in "kg"). The Rule of Six can only be used with the dose unit mcg/kg/min.

CAUTION

JCAHO (Joint Commission of Accredited Healthcare Organizations) recommends disabling the Rule of Six. The configuration is not JCAHO-compliant if Rule of Six is enabled.

The Drug Calculator uses the following formula for Rule of Six calculations, based on the patient's weight:

- For a target dose of 0.1 mcg/kg/min, the Drug Calculator multiplies 0.6 x patient weight to calculate the amount you need to add to the IV solution to equal a total of 100 ml.
- For a target dose of 1.0 mcg/kg/min, the Drug Calculator multiplies 6.0 x patient weight to calculate the amount you need to add to the IV solution to equal a total of 100 ml.

Performing Calculations for a Non-Specific Drug

The screenshot shows the 'Drug Calculator' window with the following fields and values:

Field	Value	Unit
Drug Selection	ANY DRUG	
Dose	2	mg/min
Rate	480	ml/hour
Amount	25	mg
Volume	100	ml
Concentr.	0.25	mg/ml
1 ml/h	0.004	mg/min
Weight	150	lb

Numbered callouts in the image point to:

- 1: ANY DRUG selection
- 2: Entry fields for Dose, Rate, Amount, and Volume
- 3: Calculated standardized rate (1 ml/h) and concentration (Concentr.)
- 4: Weight used for weight-dependent dose units

If a list of drugs has not been configured for your monitor, you can use the Drug Calculator to calculate drug doses for a single, generic drug called **ANY DRUG**. Selecting the arrow beside the drug name in the **Drug Calculator** window shows that are no other drugs configured.

- 1 Enter three of these four values: dose, amount, volume, rate of the infusion solution.
To enter values, select the correct unit, then select each value field and use the pop-up keypad to enter the correct value.
- 2 If you have chosen a weight-dependent dose unit, you must enter the patient weight now or choose a different unit.
If available, the patient weight from the **Patient Demographics** window is entered automatically in the **Drug Calculator** window when the Drug Calculator is accessed. To change the patient weight, select the **Weight** key then use the on-screen keypad to enter the correct value. This will not change the patient weight stored in the patient demographic information.
- 3 When you have entered three values, the Drug Calculator automatically calculates the unknown fourth value and shows it in the highlighted field. Standardized rate and concentration are also calculated.

Performing Calculations for a Specific Drug

The screenshot shows the 'Drug Calculator (Adult)' window for 'Demo Dobutamine'. The interface includes a 'Patient Category' section with radio buttons for 'Adult', 'Pedi', and 'Neo'. Below this are input fields for 'Dose' (40 mcg/kg/mn), 'Rate' (163.29 ml/hour), 'Amount' (250 mg), and 'Volume' (250 ml). There are also calculated fields for 'Concentr.' (1 mg/ml) and '1 ml/h' (16.667 mcg/min). A 'Weight' field is set to 150 lb. A 'Reset Values' button is located at the bottom left. On the right side, there is a vertical bar with a scale from 0 to 250, with a red segment at the top and a green segment below. A white arrow points to the 163.29 mark on the scale. Numbered callouts 1 through 5 are placed around the interface to highlight key features.

- 1 Patient category (**Adult**, **Pedi**, **Neo**)
 - 2 Entry fields for **Dose**, **Rate**, **Amount**, and **Volume**
 - 3 Calculated standardized rate (**1 ml/h**) and concentration (**Concentr.**)
 - 4 **Reset Values** key reverts to the configured values for this drug
 - 5 **Weight** used for weight-dependent dose units
- 1 Select the arrow beside **ANY DRUG**, then select the required drug from the list of drugs.
This opens the window for the selected drug.
 - 2 Select the correct patient category for your patient.
If you have a neonatal or pediatric patient, the **Rule of 6** choice may be available. Select if required.
 - 3 Enter the patient weight, if necessary.
If available, the patient weight from the **Patient Demographics** window is entered automatically in the **Drug Calculator** window. To change the patient weight, select the **Weight** key then use the on-screen

keypad to enter the correct value. This will not change the patient weight stored in the patient demographic information. Select the weight unit shown to change between lb and kg.

- When a specific drug is selected, the initial values for **Dose**, **Amount** and **Volume** are the configured Start values for this drug. The **Rate** is then calculated. If other values are required you can calculate any value by entering the remaining three values as described in .

The column on the right of the window shows either drug dose or dosage rate, whichever is the calculated value. The current calculated value is shown on a scale with the recommended range in green. If the current calculated value lies outside the recommended range it is shown in red.

If you have changed values in the Drug Calculator and you want to revert to the configured values, select **Reset Values** key at any time.

Charting Infusion Progress

Demo Dobutamine			Amount	Volume	Drip Time
Dose	40 mcg/kg/mn		16.67	16.67	--:--:--
Rate	163.29 ml/hour		33.33	33.33	--:--:--
Amount	250 mg		50	50	--:--:--
Volume	250 ml		66.67	66.67	--:--:--
Weight	150 lb		83.33	83.33	--:--:--
Drip Time	--:--:-- hr:min:sec		100	100	--:--:--
			116.67	116.67	--:--:--
			133.33	133.33	--:--:--
			150	150	--:--:--
			166.67	166.67	--:--:--
			183.33	183.33	--:--:--
			200	200	--:--:--
			216.67	216.67	--:--:--
			233.33	233.33	--:--:--
			250	250	--:--:--

The **Drip Table** shows you at a glance how much of the infusion has been administered to your patient and how much time is left.

- To see the **Drip Table**, in the **Drug Calculator** window, select the **Drip Table** pop-up key.

If the Drip Time exceeds 24 hours, the Drip Time timestamp shows:

--:--:--:--

Using the Titration Table

Demo Dobutamine			Dose		40 mcg/kg/mn		
Dose increments			Rate		163.29 ml/hour		
From a low of	0 mcg/kg/mn		Amount	250 mg			
To a high of	50 mcg/kg/mn		Volume	250 ml			
In increments of	1 mcg/kg/mn		Weight	150 lb			
Dose	Rate	Dose	Rate	Dose	Rate	Dose	Rate
1	4.08	11	44.91	21	85.73	31	126.55
2	8.16	12	48.99	22	89.81	32	130.63
3	12.25	13	53.07	23	93.89	33	134.72
4	16.33	14	57.15	24	97.98	34	138.8
5	20.41	15	61.23	25	102.06	35	142.88
6	24.49	16	65.32	26	106.14	36	146.96
7	28.58	17	69.4	27	110.22	37	151.05
8	32.66	18	73.48	28	114.31	38	155.13
9	36.74	19	77.56	29	118.39	39	159.21
10	40.82	20	81.65	30	122.47	40	163.29

- Currently set values for **Dose**, **Rate**, **Amount**, **Volume**, and **Weight**.
- Minimum dose, maximum dose and increments used for the table.
- Shows whether **Dose increments** or **Rate increments** are the basis of the table.

Use the **Titration Table** to see at a glance what dose your patient would receive of a drug at different infusion rates. By clicking on the blue title row of the table you can switch between the **Dose increments** and **Rate increments** view.

Values outside of the recommended range are shown in red.

To see the **Titration Table**,

- in the **Drug Calculator** window, select the pop-up key **Titration Table**.

The **Titration Table** is configured with the service Support Tool.

Documenting Drug Calculations

- In the **Drug Calculator** window, select the pop-up key **Record DrugCalc** to immediately start a recording of the current drug calculation.
- In the **Titration Table** window, select the pop-up key **Print Titration Table** to print a report of the current Titration Table.
- In the **Drip Table** window, select the pop-up key **Print Drip Table** to print a report of the current Drip Table.

IntelliBridge EC10

An IntelliBridge EC10 module transmits information from a connected external device to your monitor. The IntelliBridge EC5 ID module is used to provide identification information from the external device. Data imported from the external device, for example waveforms, measurement numerics, settings and alarms, can be displayed on the monitor, passed on to an Information Center and included in trends as appropriate. The external device may show more information than is available on the monitor. Data from IntelliBridge EC10 cannot be included in monitor trends when the label is a free-text label.

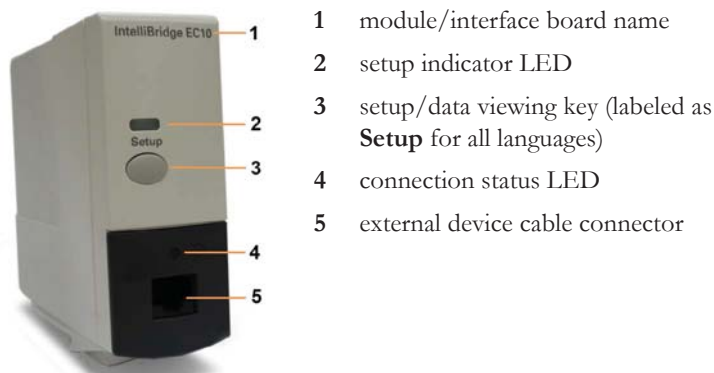

**IntelliBridge EC10
Module**

See the documentation supplied with the IntelliBridge EC5 ID module for a list of supported devices and accessories, and for configuration information.

Connecting an External Device

- 1 *When using the module:* Insert the module into the Module Rack or integrated module slot.
- 2 Check that you have the correct EC5 ID module for the external device - indicated on the EC5 label.
- 3 Connect the EC5 ID module to the external device.
- 4 Connect the EC5 to the EC10 module or Interface board using the supplied cable.
- 5 Switch the external device on.
- 6 The connection status LED (4) will flash green until it has correctly identified the external device and started communication. Check that the connection status LED then lights green continuously indicating that communication has been established.

Changing Waves and Numerics Displayed

To change the waves and numerics from the IntelliBridge module or Interface board displayed on the Screen,

- 1 Select **Main Setup, Measurements**, then **<External Device>** to enter the setup menu for the connected device.
- 2 Select **Setup Driver**.
- 3 Select **Setup Waves** or **Setup Numerics** and make the changes required.
- 4 Close the setup menu. The monitor takes a few seconds to activate the change.

Viewing the IntelliBridge Device Data Window

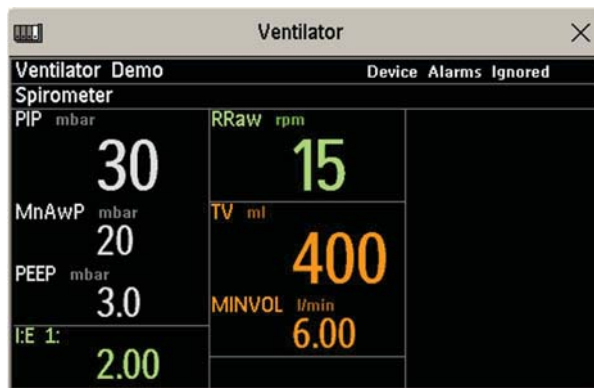

To view the IntelliBridge device data window, either

- select the Setup key on the IntelliBridge module, if available, or
- select the **External Devices** SmartKey and then select the pop-up key with the device name on it, or
- in the **Setup <External Device>** menu, select **Show Device Data**.

Check that the correct external device ID is shown in the window title.

Select the device data window then **Setup Device** to open the setup menu for the connected device.

With the **More Data** key you can page through additional data which does not fit on the first screen.

When an infusion system is connected the data is presented differently. The data from each pump is displayed in a horizontal frame in the window. Data from several infusion pumps can be displayed.

To see a detailed information window for one of the pumps, you can select data for that pump on the Screen or select the **More Data** pop-up key.

Using Screens with External Device Data

Your monitor may be configured to show external device data permanently on the Screens.

Select the device data window to display the pop-up keys that let you access the setup menu and make changes.

Alarms/INOPs from External Devices

The IntelliBridge module/Interface board itself generates INOPs, but does not generate alarms. If the external device's alarms are on, the module/Interface board transmits these to the monitor. A message in the External Device Data window tells you either **Device Alarms Ignored** or **Device Alarms Accepted** or **No Alarms Available**. External device alarms status symbols precede some, but not all, measurement labels.



The monitor is configured to accept external device alarms, but the alarms are switched off at the external device.

Alarms from external devices are transmitted to the monitor. For all numerics configured in the setup menu, an alarm condition is announced at the monitor. For one or more measurements not configured in the setup menu, an alarm is announced as a text message for the highest priority alarm. Priority is determined at the external device.

Refer to the documentation supplied with the IntelliBridge EC5 ID module for details of how alarms are announced on the monitor and the Information Center.

INOPs from the IntelliBridge Module/Interface Board

INOP Text	INOP Condition
!! No Device Data !!! No Device Data	Communication has been lost to a connected device when <ul style="list-style-type: none"> – !! a medium priority INOP or patient alarm was present – !!! a high priority INOP or patient alarm was present
No Device Data	Communication has been lost to a connected device with no (or only low priority) INOPs/physical alarms.
Device Unsupported	Device identification completed but no appropriate device driver installed
Device Chk Config	Device identification completed but communication could not be established due to errors
Device Check Setup	Device identification completed but communication could not be established due to timeout

Using Timers

With the timers function you can set timers to notify you when a specific time period has expired.

CAUTION

Do not use the timers to schedule critical patient-related tasks.

Viewing Timers

You can view currently active timers in the **Timers** window or directly on the Main Screen (if a timer has been substituted for a numeric).

To open the **Timers** window:

- Select the **Timer** SmartKey



or

- Select **Main Setup** then select **Timer**

The maximum number of timers which can be active depends on your monitor model.

For a timer with a defined run time a progress bar is shown with the run time for that timer. Next to the progress bar the elapsed time or the remaining time is shown, depending on whether the timer is counting up or down. On the left, the label of the timer and a symbol indicating the type of expiry notification is shown.

Timer Types

There are four types of timer: **Basic**, **Enhanced**, **Cyclic** and **No Limit**. A **Basic** timer has a single, defined run time and progress is shown in the progress bar. An **Enhanced** timer is like a **Basic** timer but the progress bar shows progress beyond the end of the run time. A **Cyclic** timer is like a **Basic** timer but restarts automatically when the run time is expired. A **No Limit** timer has no run time or progress bar and shows the time elapsed since the timer was started.

The type of timer is set in the monitor's Configuration Mode and is associated with the timer label.

Timer Setup Pop-up Keys

When you open the **Timers** window and select a timer, then select the setup key, the setup window opens and a selection of pop-up keys appear to let you activate and control the timers.

Pop-Up Keys	Selecting this pop-up key lets you....
Start	start the timer.
Stop	stop the timer, allowing either restarting after a pause (Start key) or clearing (Clear key).

Pop-Up Keys	Selecting this pop-up key lets you....
Clear	clear the timer, ending this timer episode.
Timers	return to the timer window showing all active timers

Setting Up Timers

The timer type, display color of the timer and whether a window automatically pops up on expiry are settings made in Configuration Mode for each timer label.

The remaining timer settings can be made in Monitoring Mode. If you change settings when a timer is running it will not be stopped. The timer will continue to count but the new settings will be applied.

To display the setup window for a timer,

- in the **Timers** window, select the required timer, then select the setup key or
- select a timer on the Screen then select **Setup Timers**.

Timer Label

You can select from a variety of specific labels, for example **Tourniquet**, **Infus**, **Docu** or from four non-specific labels **TimerA**, **TimerB**, **TimerC**, and **TimerD**. When you assign a label to a timer, the monitor automatically applies the associated configuration settings to this timer, but the timer continues counting and is not reset.

To select a label, in the **Timers** window:

- 1 Select the required timer and display the **Setup** window.
- 2 Select **Label**.
- 3 Select a specific or non-specific label from the list.

Run Time

The run time can be set between 1 minute and 96 hours. **No Limit** timers have no run time.

To set the run time, in the **Timers** window:

- 1 Select the required timer and display the **Setup** window.
- 2 Select **Run Time**.
- 3 Select a run time from the list.

Timer Counting Direction

Timers can count up or down, showing elapsed time or remaining time. **No Limit** timers automatically count up.

To change the direction, in the **Timers** window:

- 1 Select the required timer and display the **Setup** window.
- 2 Select **Direction** to switch between **Up** and **Down**.

Notification

When a timer expires (except a **No Limit** timer), the color changes to red and a message pops up briefly. Be aware that if a timer has been configured to display in light red, the color will not visibly change when the timer expires.

Additional notification is also available and can be set to:

Alarm: An INOP alarm indicates the expiry of the timer

Sound: A single tone indicates the expiry of the timer

No Sound: No additional notification

To set the additional notification, in the **Timers** window:

- 1 Select the required timer and display the **Setup** window.
- 2 Select **Notification** and select the notification level required from the list.

Timer Volume

For all timers with the notification setting **Sound**, you can set the volume of the tone.

To set the volume, in the **Timers** window:

- 1 Select the required timer and display the **Setup** window.
- 2 Select **Timer Volume** and select a volume setting from the list.

Displaying a Timer On The Main Screen

If you want to have a timer displayed on the Main Screen, you can substitute it for a numeric which is not directly associated with a wave. If limited space is available, some of the timer display elements may not be displayed. The minimum information displayed is the label and the elapsed or remaining time.



To display a timer on the Main Screen:

- 1 Select the numeric you want to substitute.
- 2 Select **Change Numeric**.
- 3 Select **Any Timer**.

Main Screen Timer Pop-up Keys

When you select a timer displayed on the Main Screen, additional pop-up keys become available:

Pop-Up Keys	Selecting this pop-up key lets you....
Setup <Timer Label>	enter the setup screen for the currently selected timer.
Change Timer	select a different timer for display.
Timers	enter the Timers window.

Displaying A Clock On The Main Screen

In the same way that you can substitute a timer for a numeric, you can also substitute a larger analog or digital clock display for a numeric.

To display a clock on the Main Screen:

- 1 Select the numeric you want to substitute.
- 2 Select **Change Numeric**.
- 3 Select **Clock**.

When you select the clock on the Main Screen you can select **Date, Time** in the menu to set the date and time.

Respiratory Loops

Using an IntelliBridge module connected to a ventilator, you can measure and store graphic representations of realtime respiratory loops. Respiratory loops can help you recognize changes in your patient's lung function, and they can also indicate a fault in the airway tubing (for example, if the respiratory loop does not close).

You can measure:

- Pressure-volume loops
- Pressure-flow loops
- Volume-flow loops.

Note that you cannot store loops from different patients and different source devices in the same list as they are patient and device specific. This prevents you from inadvertently comparing information from different patients.

Viewing Loops

In the loops display, the current loop is drawn in white, and up to six stored loops are color-coded to match their timestamps. The currently-used source device is shown in the window title.

To view respiratory loops permanently on your Screen,

- select the current Screen name to open the **Change Screen** menu, then select a Screen configured to display the loops screen element.

Select the loops screen element to access the loops pop-up keys.

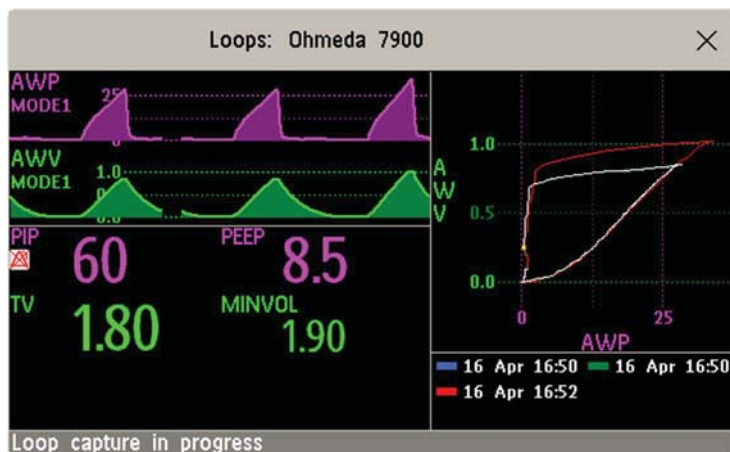

To open the **Loops** window, and its associated pop-up keys,

- select **Main Setup** then **Loops**, or select the **Loops** SmartKey, if configured.

In the **Loops** window, in addition to the stored loops, two realtime airway waves and up to nine available numerics from the source device can be shown.

Capturing and Deleting Loops

Up to six loops of each kind can be stored for reference.

To capture the current Loop and display it in the **Loops** window,

- select the **Capture Loop** pop-up key.
The monitor will prompt you to save the loop for reference, either in addition to or in place of previously stored loops.
Status messages at the bottom of the window provide information on the loop capture process.

To delete Loops from the reference list,

- Select the **Select Loop** pop-up key to view the list of stored loops and delete the loops from the list.

Showing/Hiding Loops

Colored rectangles beside the loops timestamps and color-coded with the loops tell you whether each loop is currently displayed or not:

- A filled-in rectangle marks loops currently shown in the **Loops** window
- A rectangle outline marks loops not currently shown.

Selecting the timestamp of the currently-displayed loop hides it and shows the next in the list; selecting the timestamp of a currently hidden loop displays it.

Changing Loops Display Size

To change the loops display size, in the **Loops** window, select the pop-up key **Select Size** then select

- **Size x0.5** to display loops at half the usual size
- **Size x1** to display loops at the usual size
- **Size x2** to display loops at twice the usual size

This does not affect the size of loops printed in reports.

Using the Loops Cursor

To view the coordinates for any point on a stored loop,

- 1 Select the pop-up key **Select Loop**.
- 2 Select the required loop from the list of available loops.
- 3 Use the arrow pop-up keys to move the cursor around the loop. The values for both loop axes are shown for every point on the loop.

Select the X at the top of the loop list to exit the cursor.

Changing Loops Type

To change the loop type, in the **Loops** window, select the **Loop Type** pop-up key (only available if the source device delivers three waves), then select

- **Press/Volume** to display Pressure/Volume loops
- **Flow/Volume** to display Volume/Flow loops
- **Press/Flow** to display Pressure/Flow loops.

or, if the source device only delivers two waves,

- 1 In the **Loops** window, select the **Setup Device** pop-up key to enter the setup window for the external device.
- 2 Select **Wave 1** and select pressure, flow, or volume waves as required. Repeat for **Wave 2**.

Setting Up Source Device

The source device for the loops is indicated in the **Loops** window title.

- Select the **Setup Device** pop-up key to view the settings of the current source device.

If the source device is changed, all reference loops from a previous device are cleared from the reference list when the first loop from the new source device is captured. Reconnecting the previous device recalls its reference list.

Documenting Loops

- 1 In the **Loops** window, select the pop-up key **Print Loop**
- 2 From the list of available loops, select an individual loop, or select **Print All** to print a report of all

For each loop, the report prints

- the currently-displayed loop, with the loop capture timestamp
- up to six realtime numerics provided by the loop source device
- SpO₂, etCO₂, PO₂, and PCO₂ numerics from the patient monitor, if available.

Laboratory Data

Laboratory data can be entered manually at the Information Center or at the monitor. For details on manual entry at the monitor, see “[Entering Measurements Manually](#)” on page 56. Selected laboratory data can be integrated on the monitor - values are then stored in the database and included in trends and reports and can be displayed as a numeric on the main screen. Which data can be stored and used on the monitor in this way is selected in Configuration Mode.

Viewing Received Data

When new data has been received from the Information Center a **New Lab Data received. Check Lab Results Window.** message will appear with the arrival time. To view the data, select **Main Setup** then select **Lab Results** or the **Lab Results** SmartKey.

The **Lab Results** window shows the most recent set of data received. The data is grouped into categories:

- **Blood Gases**
- **Electrolytes**
- **Hematology**
- **Metabolites**
- **Chemistry**
- **Enzymes/Markers**
- **Coagulation**
- **Urine Diagnostics**

If no results are available for a particular category, that category will not be shown. Values which were entered manually at the Information Center will be marked with an asterisk (*).

Care and Cleaning

Use only the Philips-approved substances and methods listed in this chapter to clean or disinfect your equipment. Warranty does not cover damage caused by using unapproved substances or methods.

Philips makes no claims regarding the efficacy of the listed chemicals or methods as a means for controlling infection. Consult your hospital's Infection Control Officer or Epidemiologist. For comprehensive details on cleaning agents and their efficacy refer to "Guidelines for Prevention of Transmission of Human Immunodeficiency Virus and Hepatitis B Virus to Health Care and Public-Safety Workers" issued by the U.S. Department of Health and Human Services, Public Health Service, Centers for Disease Control, Atlanta, Georgia, February 1989. See also any local policies that apply within your hospital, and country.

General Points

These instructions are valid for the monitor and all modules and extensions except for the special cases where alternative instructions are contained in this chapter.

Keep your monitor, modules, Multi-Measurement Module, Measurement Extensions, Module Rack, cables, and accessories free of dust and dirt.

After cleaning and disinfection, check the equipment carefully. Do not use if you see signs of deterioration or damage. If you need to return any equipment to Philips, decontaminate it first.

Observe the following general precautions:

- Always dilute cleaning agents according to the manufacturer's instructions or use lowest possible concentration.
- Do not allow liquid to enter the case.
- Do not immerse any part of the equipment or any accessories in liquid.
- Do not pour liquid onto the system.
- Never use abrasive material (such as steel wool or silver polish).
- Never use bleach except in an approved product listed in this chapter.
- When cleaning cables, do not allow liquid to enter the connector or to collect around connector pins.
- Avoid cleaning or disinfecting while the equipment is in operation or in direct sunlight.
- Ensure that all parts of the equipment dry completely after cleaning and disinfection.

WARNING

If you spill liquid on the equipment or accessories, or they are accidentally immersed in liquid, contact your service personnel or Philips service engineer. Do not operate the equipment before it has been tested and approved for further use.

The general care and cleaning information given here meets the requirements of Medtronic for their BIS measurement devices.

Cleaning the Equipment

Clean with a lint-free cloth, moistened with warm water (40°C/104°F maximum) and soap, or an alcohol-based cleaning agent such as ethanol 70%. Do not use strong solvents such as acetone or trichloroethylene.

Do not permit any liquid to enter the monitor case and avoid pouring it on the monitor while cleaning. Do not allow water or cleaning solution to enter the measurement connectors. Wipe around, not over, connector sockets.

CAUTION

To clean the touch-enabled display, disable the touch operation by switching off the monitor during the cleaning procedure, or by selecting and holding the **Main Screen** key until the padlock symbol appears on it, indicating that touch operation is disabled. Select and hold again to re-enable touch operation.

Before cleaning a mouse, keyboard or other connected third-party device, disconnect it from the monitor.

Disinfecting the Equipment

CAUTION

Solutions: Do not mix disinfecting solutions (such as bleach and ammonia) as hazardous gases may result.

Always clean equipment before disinfecting it.

Depending on the form of the disinfectant, use a wipe, or spray-and-wipe technique for the disinfection of equipment surfaces.

For questions regarding disinfectants not listed in the following sections, contact your Philips representative.

Disinfectants for MX750/MX850 and FMX-4

The following disinfectants have been tested for regular use on all parts of the MX750/MX850 and FMX-4:

Product Name, Dilution (v/v) ¹	Product Type ²	Manufacturer
Mikrozid [®] Sensitive Wipes	wipes	Schülke & Mayr GmbH
Bacillol [®] 30 ³	liquid, spray	BODE Chemie GmbH
Incidin [®] Active ³	powder	Ecolab Inc.
Rapid multi enzyme	wipes	3M
Super Sani-Cloth [®] Germicidal Disposable Wipes	wipes	PDI Inc.
Clinell Universal Sanitizing Wipes	wipes	Gama Healthcare
Oxivir [®] Tb Cleaner Disinfectant	liquid, spray	Diversey Inc.
Caviwipes ³	wipes	Metrex
DESCOSEPT pur	liquid	Dr. Schumacher GmbH
Descogen [®] Liquid r.f.u	liquid	Antiseptica Dr. Hans-Joachim Molitor GmbH
Hydrogen Peroxide, 3%	liquid	-

Product Name, Dilution (v/v) ¹	Product Type ²	Manufacturer
Sodium Hypochlorite, bleach, 1% ³	liquid	-
Isopropanol, 80% ³	liquid	-

¹ Where no specific information is given on the dilution, refer to the manufacturer's instructions.

² If a product is offered as wipes and liquid, with the same formula and concentration, both products are approved. Testing was performed on the product type shown here.

³ Regular use of this disinfectant increases material stress and may lead to slightly reduced lifetime of the FMX-4 housing.

Disinfectants for the MMX, X3 and Current Generation Measurement Extensions

The following disinfectants have been tested for regular use on the MMX and X3 Multi-Measurement Module and the current generation Measurement Extensions.

Product Name, Dilution (v/v) ¹	Product Type ²	Manufacturer
Isopropanol, 80%	liquid	-
Sodium Hypochlorite, bleach, 2% ³	liquid	-
Hydrogen Peroxide, 3%	liquid	-
Bacillol [®] 30	wipes	BODE Chemie GmbH
Dismozon [®] plus, 0.4%	liquid	BODE Chemie GmbH
Meliseptol [®]	liquid, spray	B. Braun Melsungen AG
Incidin [®] Foam	liquid	Ecolab Inc.
Incidin [®] Plus ³ , 0.5%	liquid	Ecolab Inc.
Oxivir [®] Tb Disinfectant Cleaner	liquid, spray	Diversey Inc.
Super Sani-Cloth [®] Germicidal Disposable Wipes	wipes	PDI Inc.
Sani-Cloth [®] PLUS Germicidal Disposable Wipes	wipes	PDI Inc.
Sani-Cloth [®] Bleach ³ Germicidal Disposable Wipes	wipes	PDI Inc.
Sani-Cloth [®] AF3 ³ Germicidal Disposable Wipes	wipes	PDI Inc.
Mikrozid [®] Sensitive Wipes	wipes	Schülke & Mayr GmbH
Mikrozid [®] PAA Wipes	wipes	Schülke & Mayr GmbH
Descogen [®] Liquid r.f.u.	liquid	Antiseptica Dr. Hans-Joachim Molitor GmbH
Lysoformin [®] , 6%	liquid	Lysoform Dr. Hans Rosemann GmbH
DESCOSEPT PUR	liquid	Dr. Schumacher GmbH
Virex [®] Tb Disinfectant Cleaner ^{3, 4}	liquid, spray	Diversey Inc.

¹ Where no specific information is given on the dilution, refer to the manufacturer's instructions.

² If a product is offered as wipes and liquid, with the same formula and concentration, both products are approved. Testing was performed on the product type shown here.

3 Do not use these disinfectants on the Bedhanger Mount or the Rotatable Quick Claw Mount.

4 Regular use of this disinfectant increases material stress and may lead to a slightly reduced lifetime of the monitor housing.

Disinfectants for the Plug-In Measurement Modules, MMS, X2 and Previous Generation Measurement Extensions

The following disinfectants have been tested for regular use on the Plug-In Measurement Modules, the MMS and X2 Multi-Measurement Modules and the previous generation Measurement Extensions.

Product Name, Dilution (v/v)	Product Type	Manufacturer
Isopropanol, 80%	liquid	-
Sodium Hypochlorite, bleach, 1%	liquid	-
Hydrogen Peroxide, 3%	liquid	-
Bacillol [®] 30	liquid, spray	BODE Chemie GmbH
Dismozon [®] plus, 0.4%	liquid	BODE Chemie GmbH
Meliseptol [®]	liquid, spray	B. Braun Melsungen AG
Incidin [®] Foam	liquid	Ecolab Inc.
Oxivir [®] Tb Cleaner Disinfectant	liquid, spray	Diversey Inc.
Super Sani-Cloth [®] Germicidal Disposable Wipes	wipes	PDI Inc.
Sani-Cloth [®] PLUS Germicidal Disposable Wipes	wipes	PDI Inc.
Mikrozid [®] Sensitive Wipes	wipes	Schülke & Mayr GmbH
Mikrozid [®] PAA Wipes	wipes	Schülke & Mayr GmbH
Descogen [®] Liquid r.f.u	liquid	Antiseptica Dr. Hans-Joachim Molitor GmbH
Lysoformin [®] , 6%	liquid	Lysoform Dr. Hans Rosemann GmbH
DESCOSEPT pur	liquid	Dr. Schumacher GmbH

Sterilizing the Equipment

Sterilization is not allowed for this monitor, related products, accessories or supplies unless otherwise indicated in the Instructions for Use that accompany the accessories and supplies.

Cleaning, Sterilizing and Disinfecting Monitoring Accessories

To clean, disinfect and sterilize reusable transducers, sensors, cables, leads, and so forth, refer to the instructions delivered with the accessory. If no instructions are delivered with the accessory, the instructions given in this chapter for cleaning, disinfecting and sterilizing the monitor are applicable.

Cleaning the SO2 Optical Module

The outside of the optical module can be cleaned as described under “[Cleaning the Equipment](#)” on [page 434](#). The compartment with the fiber-optic connection can only be cleaned with a dry cloth. Do not introduce any moisture into this compartment.

Cleaning and Disinfecting the Tympanic Temperature Accessories

Probe and Thermometer Body

- 1 Wipe the thermometer body clean with a damp cloth. The water temperature should not exceed 55°C (130°F). Do not soak, rinse, or submerge the thermometer under water.
You may add a mild detergent to the water.
- 2 Clean the probe tip with a lint free swab. If the probe tip is soiled, clean it with a dampened swab.
- 3 After you have removed all foreign matter, clean the thermometer lens at the end of the probe tip with a lint free swab or lens wipe. The thermometer lens must be free from fingerprints and/or smudges for proper operation.
- 4 Thoroughly dry all surfaces.

After cleaning wait 30 minutes for the thermometer to dry completely before using it for measurements.

CAUTION

Do not use cleaners and disinfectants such as Spray-Nine™, PhisoHex™, Hibiclens™, or Vesta-Syde™ as they may result in damage to the thermometer case.

Occasional use of a 10:1 water and hypochlorite mixture or a damp isopropyl alcohol wipe or Cidex™ or ManuKlenz™ or VIROX™ or CaviWipes™ cleansing agents is acceptable, however, prolonged or repeated use of these chemicals may result in damage to the thermometer case and display area.

Use of a cloth or sponge is recommended for cleaning. Never use an abrasive pad or an abrasive cleaner on the thermometer.

The thermometer is non-sterile. Do not use ethylene oxide gas, heat, autoclave, or any other harsh method to sterilize this thermometer.

Cleaning the Recorder Printhead (M1116B only)

If you run recordings at low speed (1 or 2cm/min) for extended periods, deposits of paper debris may collect on the print head making recordings unevenly fainter in horizontal stripes.

- 1 Remove the recorder.
- 2 Open the recorder door and un-thread the paper from behind the rubber roller.
- 3 Tear off or roll up the excess paper into the roll chamber to get it out of your way.
- 4 Thread the cloth cleaning strip instead of paper around the rubber roller until approximately two inches of the strip come out from the top of the roller.

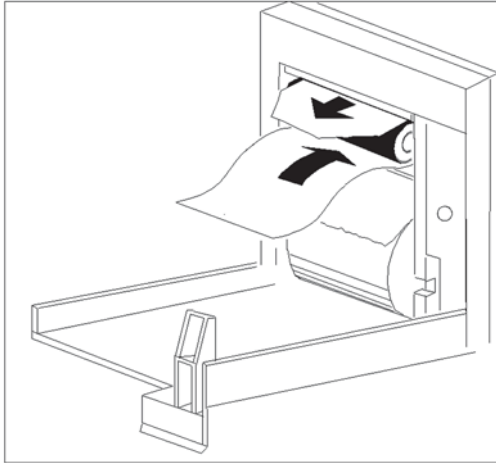

- 5 Close the recorder door, aligning both ends of the strip over the top of the door.
- 6 Holding the top end of the cleaning strip between your thumb and forefinger, pull the strip through and out of the recorder.
- 7 Open the door and ensure that the paper cavity is dust-free. Re-thread the paper and replace the recorder.

Maintenance and Troubleshooting

WARNING

Schedule: Failure on the part of the responsible individual hospital or institution employing the use of this equipment to implement a satisfactory maintenance schedule may cause undue equipment failure and possible health hazards.

Contact: If you discover a problem with any of the equipment, contact your service personnel, Philips, or your authorized supplier.

Inspecting the Equipment and Accessories

Perform a visual inspection before every use, and in accordance with your hospital's policy. With the monitor switched off:

- 1 Examine unit exteriors for cleanliness and general physical condition. Make sure that the housings are not cracked or broken, that everything is present, that there are no spilled liquids and that there are no signs of abuse.
- 2 Inspect all accessories (cables, transducers, sensors and so forth). If any show signs of damage, or the use-by date has been exceeded, do not use.
- 3 Switch the monitor on and make sure the backlight is bright enough. Check that screen is at its full brightness. If the brightness is not adequate, contact your service personnel or your supplier.
- 4 If the Multi-Measurement Module and Measurement Extensions are mounted on the monitor, make sure that they are locked into place and do not slide out without releasing the locking mechanism.

WARNING

Electrical Shock Hazard: Do not open the monitor or measurement device. Contact with exposed electrical components may cause electrical shock. Always turn off and remove power before cleaning the sensor, monitor or measurement device. Do not use a damaged sensor or one with exposed electrical contacts. Refer servicing to qualified service personnel.

Inspecting the Cables and Cords

- 1 Examine all system cables, the power plug and cord for damage. Make sure that the prongs of the plug do not move in the casing. If damaged, replace it with an appropriate Philips power cord.
- 2 Inspect the Measurement Link cable and ensure that it makes good connection with the Multi-Measurement Module and the Module Rack. Make sure that there are no breaks in the insulation.
- 3 Inspect the cable connecting the Multi-Measurement Module to the monitor. Make sure the connectors are properly engaged.
- 4 Inspect the patient cables, leads and their strain reliefs for general condition. Make sure there are no breaks in the insulation. Make sure that the connectors are properly engaged at each end to prevent rotation or other strain.
- 5 Apply the transducer or electrodes to the patient, and with the monitor switched on, flex the patient cables near each end to make sure that there are no intermittent faults.

Maintenance Task and Test Schedule

The following tasks are for Philips-qualified service professionals only. All maintenance tasks and performance tests are documented in detail in the service documentation supplied on the monitor documentation DVD.

Ensure that these tasks are carried out as indicated by the monitor's maintenance schedule, or as specified by local laws. Contact a Philips-qualified service provider if your monitor needs a safety or performance test. Clean and disinfect equipment to decontaminate it before testing or maintaining it. Never do service or maintenance on any parts of the monitor or accessories while in use with a patient.

Type	Maintenance and Test Activities	Frequency
Monitor Tests	Safety checks. Selected tests on the basis of IEC 60601-1.	At least once every two years, or as needed, after any repairs where the power supply is removed or replaced, or if the monitor has been dropped.
Monitor Maintenance	Check ECG synchronization of the monitor and defibrillator (only if hospital protocol requires use of monitor during defibrillation).	At least once every two years, or as needed.
Measurement Tests	Performance assurance for all measurements not listed below.	At least once every two years, or if you suspect the measurement values are incorrect.
Measurement Maintenance	NBP calibration	At least once every two years, or as specified by local laws.
	Microstream CO ₂ calibration and performance test	At least once a year or after 4000 operating hours.
	Mainstream and sidestream CO ₂ calibration and sidestream flow check	At least once a year, or if you suspect the measurement values are incorrect.
	Gas analyzer (G7m) accuracy check	At least once a year, or if you suspect the measurement values are incorrect, and after a software upgrade.
	Gas analyzer (G7m) calibration check (flow, ambient pressure)	At least once a year and after a software upgrade.
	Gas analyzer (G7m) flow rate adjustment	As required after calibration check.
	Gas analyzer (G7m) pneumatics check (pump, solenoid valve, leaks, including water trap and gas sample tubing)	At least once a year.

Troubleshooting

- 1 In the **Main Setup** menu, select **Revisions**.
- 2 Select the pop-up key corresponding to the status log you want to consult, for example, for the Multi-Measurement Module or the monitor.
- 3 View the status log by selecting **Status Log** from the **Monitor Revision** window.

Returning Equipment for Repair

Before returning equipment for repair:

- disinfect and decontaminate the equipment appropriately.
- ensure that all patient data has been removed (i.e. that no patient is admitted).

Disposing of the Monitor

WARNING

To avoid contaminating or infecting personnel, the environment or other equipment, make sure you disinfect and decontaminate the monitor appropriately before disposing of it in accordance with your country's laws for equipment containing electrical and electronic parts. For disposal of parts and accessories such as thermometers, where not otherwise specified, follow local regulations regarding disposal of hospital waste.

You can disassemble the monitor, Multi-Measurement Module, Module Rack and modules as described in the Service Guide.

You will find detailed disposal information on the following web page:

<http://www.healthcare.philips.com/main/about/Sustainability/Recycling/pm.wpd>

The Recycling Passports located there contain information on the material content of the equipment, including potentially dangerous materials which must be removed before recycling (for example, batteries and parts containing mercury or magnesium).



Do not dispose of electrical and electronic equipment as unsorted municipal waste. Collect it separately, so that it can be safely and properly reused, treated, recycled, or recovered.

Disposing of Empty Calibration Gas Cylinders

- 1 Empty the cylinder completely by pushing in the pin of the regulator valve or by pulling out the pin of the fill valve using a tire valve stem wrench or a pair of needle nose pliers.
 - 2 When the cylinder is empty, either remove the valve stem from the fill (or regulator) hole, or drill a hole in the cylinder.
 - 3 Write "Empty" on the cylinder and dispose of it appropriately for scrap metal.
-

WARNING

Ensure that the cylinder is completely empty before trying to remove the valve stem or drill a hole in the cylinder.

Accessories

This chapter lists Philips-approved accessories for use with patient monitors as described in this document. You can order parts and accessories from Philips supplies at www.medical.philips.com or consult your local Philips representative for details. Some accessories may not be available in all countries.

The accessories listed in this chapter include applied parts that have direct physical contact with the patient such as electrodes, sensors and cuffs. All accessories listed that can come into contact with the patient, are protected against the effects of defibrillation.

All accessories listed in this chapter comply, in combination with the patient monitor, with the requirements of IEC 60601-1-2.

WARNING

Reuse: Never reuse disposable transducers, sensors, accessories and so forth that are intended for single use, or single patient use only. Reuse may compromise device functionality and system performance and cause a potential hazard.

Philips' approval: Use only Philips-approved accessories. Using non-Philips-approved accessories may compromise device functionality and system performance and cause a potential hazard.

Packaging: Do not use a sterilized accessory if its packaging is damaged.

Correct Use: Always follow the instructions for use supplied with the accessories.

Defibrillation Protection: The defibrillation protection requires the use of the accessories specified in this section. Using other accessories may cause risk to patients, users or bystanders or may cause damage to the monitor.

ECG/Resp Accessories

The cables and accessories are designed to have special protection against electric shocks (particularly regarding allowable leakage currents), and are defibrillator proof.

The following cables may not all be available in all countries. Please check availability with your local Philips supplier.

Trunk Cables

For use with:	Part No.	Length
3-Electrode Cable Set	M1669A	2.7 m
3-Electrode Cable Set, OR	989803170171	2.7 m
5-Electrode Cable Set	M1668A	2.7 m
5-Electrode Cable Set, OR	989803170181	2.7 m
6-Electrode Cable Set	M1667A	2.7 m

37 Accessories

For use with:	Part No.	Length
10-Electrode Cable set (5+5)	M1663A	2.0 m
10-Electrode Cable set (6+4)	M1665A	2.7 m

3-Electrode Cable Sets

Description	Length	AAMI Part No.	IEC Part No.
OR Grabber shielded	1.0 m	M1675A	M1678A
ICU Grabber shielded	1.0 m	M1671A	M1672A
ICU snap shielded	1.0 m	M1673A	M1674A
ICU Clip non-shielded	0.7 m	M1624A	M1626A
Telemetry Grabber	0.85 m	989803151971	989803151981

Single Patient 3-Electrode Cable Sets

Description	Length	AAMI Part No.	IEC Part No.
ICU Grabber shielded	1.0 m	989803173121	989803174201
ICU Grabber shielded	0.84 m	989803173141	--

5-Electrode Cable Sets

Description	Length	AAMI Part No.	IEC Part No.
OR Grabber shielded	1.0 m/1.6 m	M1973A	M1974A
ICU Grabber shielded	1.0 m/1.6 m	M1968A	M1971A
ICU Snap shielded	1.0 m/1.6 m	M1644A	M1645A
ICU Miniclip non-shielded	0.7 m/1.3 m	M1647A	M1648A
ICU DIN-to-tab adapter	1.0 m/1.6 m	989803192181	989803192191
Telemetry Grabber	0.85 m	989803152051	989803152061
Telemetry Snap	0.85 m	989803152071	989803152081

Single Patient 5-Electrode Cable Sets

Description	Length	AAMI Part No.	IEC Part No.
ICU Grabber shielded	1.0 m	989803173131	989803174211
ICU Grabber shielded	0.85 m	989803173151	--

6-Electrode Cable Sets

Description	Length	AAMI Part No.	IEC Part No.
OR Grabber	1.0 m/1.6 m	M1684A	M1685A
ICU Grabber	1.0 m/1.6 m	M1680A	M1681A

Description	Length	AAMI Part No.	IEC Part No.
ICU Snap	1.0 m/1.6 m	M1682A	M1683A
ICU DIN-to-tab adapter	1.0 m/1.6 m	989803192221	989803192231
Telemetry Grabber	0.85 m	989803152131	989803152141

Single Patient 6-Electrode Cable Sets

Description	Length	AAMI Part No.	IEC Part No.
ICU Grabber, shielded	1.0 m	989803197511	989803197521

10-Electrode (5+5) Cable Sets

Description	Length	AAMI Part No.	IEC Part No.
ICU Grabber, chest, shielded	1.0 m	M1976A	M1978A
ICU Snap, chest, shielded	1.0 m	M1602A	M1604A
OR Grabber, chest, shielded	1.0 m	M1979A	M1984A
ICU DIN-to-tab adapter	1.0 m	989803192201	989803192211
For Limb Leads see 5-electrode cable sets			

Single Patient 10-Electrode (5+5) Cable Sets

Description	Length	AAMI Part No.	IEC Part No.
ICU Grabber, chest, shielded	1.0 m	989803192141	989803192151

10-Electrode (6+4) Cable Sets

Description	Length	AAMI Part No.	IEC Part No.
ICU Grabber, chest, shielded	1.0 m	M1532A	M1533A
OR Grabber, chest, shielded	1.0 m	M1557A	M1558A
ICU DIN-to-tab adapter	1.0 m	989803192241	989803192251
For Limb Leads see 6-electrode cable sets			

One-piece Cables

Description	Length	AAMI Part No.	IEC Part No.
3-lead Grabber, ICU	1.0 m	989803143181	989803143171
5-lead Grabber, ICU	1.0 m	989803143201	989803143191

Miscellaneous Accessories

Description		Part No.
Set organizer for shielded leadsets - grabber and snap	5-electrode	M1504A
Tab/Snap adapters, 10 pieces		989803193821

NBP Accessories

These cuffs and tubings are designed to have special protection against electric shocks (particularly regarding allowable leakage currents), and are defibrillator proof. You can use them during electrosurgery.

Adult/Pediatric Reusable Comfort Care Cuffs

Patient Category	Limb Circumference	Part No.	Tubing
Adult (Thigh)	42 - 54 cm	M1576A	M1598B (1.5 m) or M1599B (3 m)
Large Adult	34 - 43 cm	M1575A	
Large Adult XL	34 - 43 cm	M1575XL	
Adult	27 - 35 cm	M1574A	
Adult XL	27 - 35 cm	M1574XL	
Small Adult	20.5 - 28 cm	M1573A	
Small Adult XL	20.5 - 28 cm	M1573XL	
Pediatric	14 - 21.5 cm	M1572A	
Infant	10 - 15 cm	M1571A	

Adult/Pediatric Reusable Comfort Care Cuff Kits

Cuff Kits	Part No.
Infant, pediatric, small adult, adult	M1577A
Small adult, adult, large adult, thigh	M1578A
Infant, pediatric, small adult, adult, large adult, thigh	M1579A
Small adult XL, adult XL, large adult XL	M1579XL

Adult/Pediatric Reusable Easy Care Cuffs

Patient Category	Limb Circumference	Part No. (Pack of five)	Tubing
Adult Thigh	44 - 56 cm	M4559B (M4559B5)	M1598B (1.5 m) or M1599B (3 m)
Large Adult X-Long	35 - 45 cm	M4558B (M4558B5)	
Large Adult	35 - 45 cm	M4557B (M4557B5)	
Adult X-Long	27.5 - 36 cm	M4556B (M4556B5)	
Adult	27.5 - 36 cm	M4555B (M4555B5)	
Small Adult	20.5 - 28.5 cm	M4554B (M4554B5)	
Pediatric	14 - 21.5 cm	M4553B (M4553B5)	
Infant	10 - 15 cm	M4552B (M4552B5)	

Adult/Pediatric Reusable Easy Care Cuff Kits

Cuff Kits	Part No.
Assortment pack of one small adult, one adult, one large adult and one thigh cuff	864288
Assortment pack of one infant, one pediatric, one small adult and one adult cuff	864289
Assortment pack of one infant, one pediatric, one small adult, one adult, one large adult and one thigh cuff	864290
Assortment pack of one small adult, one adult, one adult X-long, one large adult, one large adult X-long and one thigh cuff	864291

Adult/Pediatric Multi Care Cuffs

Patient Category	Limb Circumference	Part No.	Tubing
Adult Thigh	42.0 - 54.0 cm	989803183371	M1598B (1.5 m) or M1599B (3 m)
Large Adult	34.0 - 43.0 cm	989803183361	
Adult X-Long	27.0 - 35.0 cm	989803183351	
Adult	27.0 - 35.0 cm	989803183341	
Small Adult	20.5 - 28.0 cm	989803183331	
Pediatric	14.0 - 21.5 cm	989803183321	
Infant	10.0 - 15.0 cm	989803183311	

Adult/Pediatric Single Patient, Gentle Care Cuffs

Patient Category	Limb Circumference	Part No.	Tubing
Adult (Thigh)	44 - 56 cm	M4579B	M1598B (1.5 m) or M1599B (3 m)
Large Adult X-Long	35 - 45 cm	M4578B	
Large Adult	35 - 45 cm	M4577B	
Adult X-Long	27.5 - 36 cm	M4576B	
Adult	27.5 - 36 cm	M4575B	
Small Adult	20.5 - 28.5 cm	M4574B	
Pediatric	14.0 - 21.5 cm	M4573B	
Infant	10 - 15 cm	M4572B	

Adult/Pediatric Single Care Cuffs

Patient Category	Limb Circumference	Part No.	Tubing
Large Adult	35.0 - 45.0 cm	989803182321	M1598B (1.5 m) or M1599B (3 m)
Adult X-Long	27.5 - 36.0 cm	989803182311	
Adult	27.5 - 36.0 cm	989803182301	
Small Adult	20.5 - 28.5 cm	989803182291	
Pediatric	14.0 - 21.5 cm	989803182281	

Neonatal/Infant Single Patient Cuffs

Cuffs	Limb Circumference	Part No.	Tubing
Size 1	3.1 - 5.7 cm	M1866B	M1596C (1.5 m) or M1597C (3 m)
Size 2	4.3 - 8.0 cm	M1868B	
Size 3	5.8 - 10.9 cm	M1870B	
Size 4	7.1 - 13.1 cm	M1872B	
Size 5 (Infant)	10 - 15 cm	M1873B	

Neonatal/Infant Single Patient, Soft Cuffs

Cuffs	Limb Circumference	Part No.	Tubing
Size 1	3.1 - 5.7 cm	M1866S	M1596C (1.5 m) or M1597C (3 m)
Size 2	4.3 - 8.0 cm	M1868S	
Size 3	5.8 - 10.9 cm	M1870S	
Size 4	7.1 - 13.1 cm	M1872S	
Size 5 (Infant)	10 - 15 cm	M1873S	

Neonatal/Infant Cuff Kits

Cuff Kits	Part No.
Standard, Single Patient: 5 x M1866B, 10 x M1868B, 20 x M1870B, 10 x M1872B, and 5 x M1873B	989803167541
Soft, Single Patient: 5 x M1866S, 10 x M1868S, 20 x M1870S, 10 x M1872S, 5 x M1873S	989803167551

Invasive Pressure Accessories



These transducers and accessories are designed to have special protection against electric shocks (particularly regarding allowable leakage currents), and are defibrillator proof.

If you are using the M3012A Hemodynamic Measurement Extension, and you want to measure temperature and invasive pressure at the same time, we recommend that you use the pressure transducer CPJ840J6, with a round module connector piece, and not a transducer with a square connector. Pressure transducers with square connectors may make it difficult to connect the adjacent Temperature connector at the same time.

Contact ICU Medical or Edwards Lifesciences for compatible disposable pressure transducers and accessories.

Pressure transducers and accessories	Part No.
Reusable pressure transducer 5 μ V/V/mmHg sensitivity	CPJ840J6
Sterile disposable pressure domes for CPJ840J6 (pack of 50)	CPJ84022
Transducer holder for CPJ840J6 (pack of 4)	CPJ84046
IV pole mount for CPJ840J6	CPJ84447
Monitoring Line Set for CPJ840J6	CPJ84026
Dual IBP adapter	989803199741

Pressure transducer kits	Part No.
PiCCO monitoring kit, 30 cm pressure line, includes PV4046 injectate temperature sensor housing for M1646A	PV8103
PiCCO monitoring kit, 150 cm pressure line, includes PV4046 injectate temperature sensor housing for M1646A	PV8115
PiCCO monitoring kit, 150 cm pressure line, includes PV4046 injectate temperature sensor housing for M1646A and central venous pressure line	PV8115CVP
PULSION Pressure Interface Cable for disposable pressure transducer	PMK 206

SpO2 Accessories

Some Nellcor sensors contain natural rubber latex which may cause allergic reactions. See the Instructions for Use supplied with the sensors for more information.

Do not use more than one extension cable with any sensors or adapter cables. Do not use an extension cable with:

- Masimo adapter cables,
- Philips reusable sensors or adapter cables with part numbers ending in -L (indicates "Long" version) or with a cable longer than 2 m.

All listed sensors operate without risk of exceeding 41°C on the skin, if the initial skin temperature does not exceed 35°C.

Make sure that you use only the accessories that are specified for use with your monitor and measurement technology, otherwise patient injury can result.

Always use the MAXFAST forehead sensor with the foam headband provided by Nellcor.

Some sensors may not be available in all countries.

Philips only claims compatibility of accessories with Philips measurement devices. For accessory compatibility information for third party measurement devices (e.g. Medtronic/Nellcor IntelliVue Module or Masimo rainbow SET IntelliVue Module), please refer to the respective measurement device's Instructions for Use.

Philips SpO2 Technology

This section lists accessories for use with Philips SpO₂ technology. For accessory lists for other SpO₂ technologies, refer to the following sections and the instructions for use provided with these devices. Option #A01/#SP1 is the standard Philips FAST-SpO₂ version; Option #A02 (no longer sold) is the Nellcor OxiMax-compatible version.

Philips Reusable Sensors

Product Number	Description	Compatible with		Comments
		Option A01/SP1	Option A02	
M1191A/B	Adult sensor (2 m cable), for patients over 50 kg. Any finger, except thumb.	yes	no	No adapter cable required.
M1191AL/BL	M1191A/B with longer cable (3 m)	yes	no	
M1192A	Small adult, pediatric sensor (1.5 m cable) for patients between 15 kg and 50 kg. Any finger except thumb.	yes	no	
M1193A	Neonatal sensor (1.5 m cable) for patients between 1 kg and 4 kg. Hand or foot.	yes	no	
M1194A	Ear sensor (1.5 m cable) for patients over 40 kg.	yes	no	
M1195A	Infant sensor (1.5 m cable) for patients between 4 kg and 15 kg. Any finger except thumb.	yes	no	
M1196A	Adult clip sensor (3 m cable) for patients over 40 kg. Any finger except thumb.	yes	no	
M1196S	Adult clip sensor (2 m cable) for patients over 40 kg. Any finger except thumb.	yes	no	

Product Number	Description	Compatible with		Comments
		Option A01/SP1	Option A02	
M1191T	Adult sensor (0.45 m cable), for patients over 50 kg. Any finger, except thumb.	yes	no	Requires M1943A (1 m) or M1943AL (3 m) adapter cable.
M1192T	Small adult, pediatric sensor (0.45 m cable) for patients between 15 kg and 50 kg. Any finger except thumb.	yes	no	
M1193T	Neonatal sensor (0.9 m cable) for patients between 1 kg and 4 kg. Hand or foot.	yes	no	
M1196T	Adult clip sensor (0.9 m cable) for patients over 40 kg. Any finger except thumb.	yes	no	

Philips Disposable Sensors

Product Number	Description	Compatible with		Comments
		Option A01/SP1	Option A02	
M1901B ¹	Identical to OxiMax MAXN	yes	yes	Option A01/SP1: Use M1943A or M1943AL adapter cable.
M1902B ¹	Identical to OxiMax MAXI	yes	yes	
M1903B ¹	Identical to OxiMax MAXP	yes	yes	
M1904B ¹	Identical to OxiMax MAXA	yes	yes	
M1131A	Adult/Pediatric finger sensor, 0.45 m cable (patient size > 20 kg)	yes	no	Use M1943A or M1943AL adapter cable.
M1132A	Infant finger or toe sensor, 0.9 m cable (patient size 3 - 10 kg)	yes	no	Use M1943A or M1943AL adapter cable.
M1133A	Adult/Infant/Neonatal, 0.9 m cable Foot or hand for neonates < 3 kg Big toe or thumb for patients between 10 kg and 20 kg Any finger except thumb for patients > 40 kg	yes	no	Use M1943A or M1943AL adapter cable.
M1134A	Adhesive-free, Adult/Infant/Neonatal, 0.9 m cable Foot or hand for neonates < 3 kg Big toe or thumb for patients between 10 kg and 20 kg Any finger except thumb for patients > 40 kg	yes	no	Use M1943A or M1943AL adapter cable.

¹Not available in the USA

Nellcor Sensors

Nellcor sensors must be ordered from Nellcor/Covidien.

Product Number	Description	Compatible with		Comments
		Option A01/SP1	Option A02	
OxiMax MAXA	Adult finger sensor (patient size > 30 kg)	yes	yes	Option A01/SP1: Use M1943A or M1943AL adapter cable. Option A02: Must use M1943NL adapter cable.
OxiMax MAXAL	OxiMax MAXA with long cable	yes	yes	
OxiMax MAXP	Pediatric foot/hand sensor (patient size 10 - 50 kg)	yes	yes	
OxiMax MAXI	Infant foot/hand sensor (patient size 3 - 20 kg)	yes	yes	
OxiMax MAXN	Adult finger or neonatal foot/hand sensor (patient size > 40 kg or < 3 kg)	yes	yes	
MAXFAST	Forehead sensor (patient size ≥ 10 kg)	no	yes	Must use M1943NL adapter cable.
OxiMax MAXR	Adult nasal sensor (patient size > 50 kg)	no	yes	
OxiMax SC-A	Adult SoftCare sensor (patient size > 40 kg)	no	yes	
OxiMax SCNEO-I	Neonatal SoftCare sensor (patient size 1.5 - 5 kg)	no	yes	
OxiMax SC-PR-I	Pre-term infant SoftCare sensor (patient size < 1.5 kg)	no	yes	
Oxisensor II D-25	Adult sensor (patient size > 30 kg)	yes	no	Must use M1943A or M1943AL adapter cable.
Oxisensor II D-20	Pediatric sensor (patient size 10 - 50 kg)	yes	no	
Oxisensor II I-20	Infant sensor (patient size 3 - 20 kg)	yes	no	
Oxisensor II N-25	Neonatal sensor (patient size < 3 kg or > 40 kg)	yes	no	
Oxicliq A	See OxiMax MAXA	yes	yes	Option A01/SP1: Use M1943A or M1943AL adapter cable together with OC-3 adapter cable. Option A02: Must use M1943NL adapter cable together with OC-3 adapter cable.
Oxicliq P	See OxiMax MAXP	yes	yes	
Oxicliq I	See OxiMax MAXI	yes	yes	
Oxicliq N	See OxiMax MAXN	yes	yes	
Oxiband OXI-A/N	Adult/neonatal sensor	no	yes	Must use M1943NL adapter cable.
Oxiband OXI-P/I	Pediatric/infant sensor	no	yes	
Durasensor DS100A-1	Adult finger clip sensor (patient size > 40 kg)	no	yes	
Dura-Y D-YS	Y-sensor	no	yes	

Extension Cables and Adapter Cables for Philips and Nellcor Sensors

Product Number	Description	Compatible with		Comments
		Option A01/SP1	Option A02	
M1941A	Extension cable (2 m)	yes	no	For use with Philips reusable sensors and M1943A adapter cable.
M1943A	Adapter cable (1.1 m cable)	yes	no	Adapter cable for Philips/Nellcor disposable sensors.
M1943AL	Adapter cable (3 m cable)	yes	no	
M1943NL	OxiMax adapter cable (3 m cable)	no	yes	Adapter cable for Philips disposable/ Nellcor disposable and reusable sensors.
OC-3	Adapter Cable for Oxiciq sensors	yes	yes	Available from Nellcor/ Covidien only.

Masimo Sensors

Masimo LNCS Reusable Sensors

Product Number	Description	Compatible with		Philips Part Number
		Option A01	Option A02	
LNCS DCI	Adult Finger Sensor (> 30 kg)	yes	no	n/a
LNCS DCIP	Pediatric Finger Sensor (10 - 50 kg)	yes	no	n/a
LNCS YI	Multi-Site Sensor (> 1kg)	yes	no	n/a
LNCS TC-I	Ear Sensor (> 30 kg)	yes	no	n/a

Masimo LNCS Disposable Adhesive Sensors

Product Number	Description	Compatible with		Philips Part Number
		Option A01	Option A02	
LNCS Amtx	Adult Finger Sensor, 18 inch/45 cm (> 30 kg)	yes	no	n/a
LNCS Amtx-3	Adult Finger Sensor, 3 feet/90 cm (> 30 kg)	yes	no	n/a
LNCS Pmtx	Pediatric Finger Sensor, 18 inch/45 cm (10 - 50 kg)	yes	no	n/a
LNCS Pmtx-3	Pediatric Finger Sensor, 3 feet/90 cm (10 - 50 kg)	yes	no	n/a
LNCS Inf	Infant Toe Sensor, 18 inch/45 cm (3 - 20 kg)	yes	no	n/a
LNCS Inf-3	Infant Toe Sensor, 3 feet/90 cm (3 - 20 kg)	yes	no	n/a

37 Accessories

Product Number	Description	Compatible with		Philips Part Number
		Option A01	Option A02	
LNCS Neo	Neonatal Foot Sensor, 18 inch/45 cm (< 3 kg) or Adult Finger Sensor 18 inch/45 cm (> 40 kg)	yes	no	n/a
LNCS Neo-3	Neonatal Foot Sensor, 3 feet/90 cm (< 3 kg) or Adult Finger Sensor, 3 feet/90 cm (> 40 kg)	yes	no	n/a
LNCS NeoPt	Neonatal pre-term sensitive skin Sensor 18 inch/45 cm (< 1 kg)	yes	no	n/a
LNCS NeoPt-3	Neonatal pre-term sensitive skin Sensor 3 feet/90 cm (< 1 kg)	yes	no	n/a

Adapter Cable for Masimo Sensors

Product Number	Description	Compatible with		Philips Part Number
		Option A01	Option A02	
LNC MP10	LNCS MP Series Patient Cable (3.0 m) Adapter Cable for Masimo LNCS Sensors	yes	no	989803148221

Nellcor SpO₂ Technology

This section lists accessories for use with Nellcor SpO₂ technology. Nellcor SpO₂ technology is included in options #A04, #SP4, and #SP6 of the respective measurement devices.

Nellcor Sensors

The following sensors can only be ordered from Nellcor.

For application site, please refer also to the Instructions for Use provided with the sensors.

Product Name	Description
OxiMax MAX-A	Adult sensor
OxiMax MAX-AL	Adult sensor (long cable)
OxiMax MAX-P	Pediatric sensor
OxiMax MAX-I	Infant sensor
OxiMax MAX-N	Neonatal sensor
OxiCliq A	Adult
OxiCliq P	Pediatric
OxiCliq I	Infant
OxiCliq N	Neonatal
OxiMax MAX-R	Adult nasal sensor
MAX-FAST	Forehead sensor
Oxiband OXI-A/N	Adult / neonatal sensor

Product Name	Description
Oxiband OXI-P/I	Pediatric / infant sensor
SC-A	Adult SoftCare sensor
SC-NEO	Neonatal SoftCare sensor
SC-PR	Preterm infant SoftCare sensor
DS100A	Reusable adult finger clip sensor
Dura-Y D-YS	Reusable Y-sensor

Philips Disposable Sensors

Philips disposable sensors M1901B, M1902B, M1903B and M1904B are not available in the USA.

For application site, please refer also to the Instructions for Use provided with the sensors.

Product Name	Description
M1904B	Identical to OxiMax MAX-A
M1903B	Identical to OxiMax MAX-P
M1902B	Identical to OxiMax MAX-I
M1901B	Identical to OxiMax MAX-N

Extensions and Adapter Cables for Philips and Nellcor Sensors

Product Name	Description
M1943NL	Philips adapter cable (3 m), needed for Philips disposable sensors and Nellcor sensors
OC-3 ^a	Nellcor adapter cable needed for Nellcor OxiCliq sensors in addition to M1943NL adapter cable

a. Can only be ordered from Nellcor

Masimo SpO₂ Technology

This section lists accessories for use with Masimo SpO₂ technology. Masimo SET technology is included in options #A03/#SP3 and Masimo rainbow SET technology is included in options #A05/#SP5 of the respective measurement devices.

Masimo Reusable Sensors

Product Name	Description	Compatible with:	
		Masimo SET	Masimo rainbow SET
LNC Sensors			
LNCS DCI	Adult Finger Sensor (>30 kg)	yes	yes
LNCS DCIP	Pediatric Finger Sensor (10-50 kg)	yes	yes
LNCS TC-I	Adult Ear Lobe Sensor (>30 kg)	yes	yes

Product Name	Description	Compatible with:	
		Masimo SET	Masimo rainbow SET
LNCS YI	Neonate Multi-Site Sensor Foot (1-10 kg), Finger/Great Toe (>10 kg)	yes	yes
LNCS-TF-I	Adult Forehead Sensor (>30 kg)	yes	yes
LNCS DBI	Adult Finger Sensor (>30 kg)	no	yes
M-LNC Sensors			
M-LNCS DCI	Adult Finger Sensor (>30 kg)	no	yes
M-LNCS DCIP	Pediatric Finger Sensor (10-50 kg)	no	yes
M-LNCS TC-I	Adult Ear Lobe Sensor (>30 kg)	no	yes
M-LNCS YI	Neonate Multi-Site Sensor Foot (1-10 kg), Finger/Great Toe (>10 kg)	no	yes
M-LNCS TF-I	Adult Forehead Sensor (>30 kg)	no	yes
M-LNCS DBI	Adult Finger Sensor (>30 kg)	no	yes
rainbow Sensors			
rainbow DCI SC-200*	Adult Finger Sensor for SpHb/SpO ₂ /SpMet, 3 feet/90 cm (>30 kg)	no	yes
rainbow DCIP SC-200*	Pediatric Finger Sensor for SpHb/SpO ₂ /SpMet, 3 feet/90 cm (10-50 kg)	no	yes
rainbow DCI SC-400*	Adult Finger Sensor for SpHb/SpO ₂ /SpMet, 3 feet/90 cm (>30 kg)	no	yes
rainbow DCIP SC-400*	Pediatric Finger Sensor for SpHb/SpO ₂ /SpMet, 3 feet/90 cm (10-50 kg)	no	yes
rainbow DCI SC-1000*	Adult Finger Sensor for SpHb/SpO ₂ /SpMet, 3 feet/90 cm (>30 kg)	no	yes
rainbow DCIP SC-1000*	Pediatric Finger Sensor for SpHb/SpO ₂ /SpMet, 3 feet/90 cm (10-50 kg)	no	yes
rainbow DCI	Adult Sensor, SpO ₂ /SpCO/SpMet, 3 feet/90 cm (>30 kg)	no	yes
rainbow DCIP	Pediatric/Slender Digit Sensor, SpO ₂ /SpCO/SpMet, 3 feet/90 cm (10-50 kg)	no	yes

*These sensors are only supported, if the SpHb option is activated in the measurement device.

Masimo Reusable Sensors

Product Name	Description	Compatible with:	
		Masimo SET	Masimo rainbow SET
LNC and M-LNC Sensors			
LNCS S-ROS 3U	Universal Finger Sensor (SpO ₂)	no	yes
M-LNCS S-ROS 3U	Universal Finger Sensor (SpO ₂)	no	yes
S-DOS 25	Adult Finger Sensor (SpO ₂) (>30 kg)	no	yes
S-DOS 20	Pediatric Finger Sensor (SpO ₂) (10–50 kg)	no	yes

Product Name	Description	Compatible with:	
		Masimo SET	Masimo rainbow SET
S-DOS 25L	Adult/Neonatal Finger/Foot Sensor (SpO ₂) (>30 kg/<3 kg)	no	yes
S-DOS 20L	Infant Finger Sensor (SpO ₂) (3–30 kg)	no	yes
S-DOS 30L	Large Adult Finger Sensor (SpO ₂) (>40 kg)	no	yes
S-DOS 25Pt-L	Neonatal Finger Sensor (SpO ₂) (<1 kg)	no	yes
S-DOS 20L-500	Neonatal Finger Sensor (SpO ₂) (<1 kg)	no	yes
rainbow Sensors			
rainbow R2-25 (R2-25a and R2-25r)	Adult Two-Piece Finger Sensor, R2-25a adhesive sensor, and R2-25r reusable sensor (SpO ₂ /SpHb/SpMet) (>30 kg)	no	yes
rainbow R2-20 (R2-20a and R2-20r)	Pediatric Two-Piece Finger Sensor, R2-20a adhesive sensor, and R2-20r reusable sensor (SpO ₂ /SpHb/SpMet) (10-50 kg)	no	yes

Masimo Disposable Sensors

Product Name	Description	Compatible with:	
		Masimo SET	Masimo rainbow SET
LNC Sensors			
LNCS Amtx	Adult Finger Sensor (>30 kg)	yes	yes
LNCS Amtx-3	Adult Finger Sensor (>30 kg)	yes	yes
LNCS Pmtx	Pediatric Finger Sensor (10-50 kg)	yes	yes
LNCS Pmtx-3	Pediatric Finger Sensor (10-50 kg)	yes	yes
LNCS Inf	Infant Great Toe Sensor (3-20 kg)	yes	yes
LNCS Inf-3	Infant Great Toe Sensor (3-20 kg)	yes	yes
LNCS Inf-L	Infant Thumb/Great Toe Sensor (3-20 kg)	no	yes
LNCS Neo	Neonate Foot/Finger Sensor (<3 kg/>40 kg)	yes	yes
LNCS Neo-3	Neonate Foot/Finger Sensor (<3 kg/>40 kg)	yes	yes
LNCS Neo-L	Neonate Foot/Finger Sensor (<3 kg/>40 kg)	no	yes
LNCS NeoPt	Neonate Foot Sensor (<1 kg)	yes	yes
LNCS NeoPt-3	Neonate Foot Sensor (<1 kg)	yes	yes
LNCS NeoPt-500	Neonate Foot Sensor 18 inch/45 cm (<1 kg)	no	yes
LNCS NeoPt-L	Neonate Hand/Foot Sensor (<1 kg)	no	yes
LNCS Trauma	Adult Finger Sensor (>30 kg)	yes	yes
LNCS Newborn Neonatal	Neonatal Foot Sensor (<3 kg)	yes	yes
LNCS Newborn Infant/ Pediatric	Infant/Pediatric Great Toe/Finger Sensor (3-10 kg/10-30 kg)	yes	yes
LNCS E-1	Adult/Pediatric/ Disposable Ear Sensor (>30 kg)	no	yes

37 Accessories

Product Name	Description	Compatible with:	
		Masimo SET	Masimo rainbow SET
M-LNC Sensors			
M-LNCS Amtx	Adult Finger Sensor, 18 inch/45 cm (>30 kg)	no	yes
M-LNCS Amtx-3	Adult Finger Sensor, 3 feet/90 cm (>30 kg)	no	yes
M-LNCS Pmtx	Pediatric Finger Sensor, 18 inch/45 cm (10-50 kg)	no	yes
M-LNCS Pmtx-3	Pediatric Finger Sensor, 3 feet/90 cm (10-50 kg)	no	yes
M-LNCS Inf	Infant Great Toe Sensor, 18 inch/45 cm (3-20 kg)	no	yes
M-LNCS Inf-3	Infant Great Toe Sensor, 3 feet/90 cm (3-20 kg)	no	yes
M-LNCS Inf-L	Infant Thumb/Great Toe Sensor (3-20 kg)	no	yes
M-LNCS Neo	Neonatal/Adult Foot/Finger Sensor, 18 inch/45 cm (<3 kg/>40 kg)	no	yes
M-LNCS Neo-3	Neonatal/Adult Foot/Finger Sensor, 3 feet/90 cm (<3 kg/>40 kg)	no	yes
M-LNCS Neo-L	Neonatal Hand/Foot Sensor (<3 kg) Finger/Toe (>40 kg)	no	yes
M-LNCS NeoPt	Neonatal Sensitive Skin Foot Sensor, 18 inch/45 cm (<1 kg)	no	yes
M-LNCS NeoPt500	Neonatal Non-adhesive Foot Sensor, 18 inch/45 cm (<1 kg)	no	yes
M-LNCS NeoPt-L	Neonatal Sensitive Skin Hand/Foot Sensor (<1 kg)	no	yes
M-LNCS NeoPT-3	Neonatal Sensitive Skin Foot Sensor, 3 feet/90 cm (<1 kg)	no	yes
M-LNCS Trauma	Adult Finger Sensor (>30 kg)	no	yes
M-LNCS Newborn Neonatal	Neonatal Foot Sensor (<3 kg)	no	yes
M-LNCS Newborn Infant/ Pediatrics	Infant/Pediatric Great Toe/Finger Sensor (3-10 kg/10-30 kg)	no	yes
M-LNCS Blue	Neonatal/Infant/Pediatric Great Toe/Thumb Sensor for patients with congenital cyanotic cardiac lesions (2.5-30 kg)	no	yes
M-LNCS E-1	Adult/Pediatric Disposable Ear Sensor (>30 kg)	no	yes
rainbow Sensors			
rainbow R1 25	Adult Finger Sensor for SpO ₂ /SpHb/SpMet (>30 kg)	no	yes
rainbow R25	Adult Finger Sensor for SpO ₂ /SpCO/SpMet (>30 kg)	no	yes
rainbow R1 25L	Adult Finger Sensor for SpHb/SpO ₂ /SpMet (>30 kg)	no	yes
rainbow R25-L	Adult/Neonatal Adhesive Finger/Hand/Foot Sensor for SpO ₂ /SpCO/SpMet (<3 kg/>30 kg)	no	yes
rainbow R20	Pediatric Finger Sensor for SpO ₂ /SpCO/SpMet (10-50 kg)	no	yes
rainbow R1 20	Pediatric Finger Sensor for SpO ₂ /SpHb/SpMet (10-50 kg)	no	yes
rainbow R1 20L	Infant Finger/Thumb/Great Toe Sensor for SpHb/SpO ₂ /SpMet (3-10 kg/ 10-30 kg)	no	yes
rainbow R20-L	Infant Finger/Thumb/Great Toe Sensor for SpO ₂ /SpCO/SpMet (3-10 kg/ 10-30 kg)	no	yes

Product Name	Description	Compatible with:	
		Masimo SET	Masimo rainbow SET
rainbow Respiratory Acoustic Sensors (RAS)			
RAS-125c Acoustic Respiration	Adult/Pediatric Neck Sensor for RRac (>10 kg)	no	yes

Masimo Compatible Sensor Adapter Cables

Product Name	Description	Philips Part Number
LNC MP10	Masimo SET to LNCS, Patient Cable, Straight, 10 feet/3.04 m	989803148221
RED 25 LNC-10	rainbow 25-pin to LNCS, Patient Cable, Straight, 10 feet/3.04 m	989803186501
RED 25 LNC-4	rainbow 25-pin to LNCS, Patient Cable, Straight, 4 feet/1.21 m	989803186531
RED 25 LNC-4RA	rainbow 25-pin to LNCS, Patient Cable, Right Angle, 4 feet/1.21 m	
RED 25 LNC-1	rainbow 25-pin to LNCS, Patient Cable, Straight, 1 foot/0.35 m	
RED 25 LNC-1RA	rainbow 25-pin to LNCS, Patient Cable, Right Angle, 1 foot/0.35 m	
rainbow RC25-12	rainbow 25-pin to M-LNCS, Patient Cable, Straight, 12 feet/3.65 m	989803186471
rainbow RC25-12RA	rainbow 25-pin to M-LNCS, Patient Cable, Right Angle, 12 feet/3.65 m	
rainbow RC25-4	rainbow 25-pin to M-LNCS, Patient Cable, Straight, 4 feet/1.21 m	989803182421
rainbow RC25-4RA	rainbow 25-pin to M-LNCS, Patient Cable, Right Angle, 4 feet/1.21 m	989803182411
rainbow RC25-1	rainbow 25-pin to M-LNCS, Patient Cable, Straight, 1 foot/0.35 m	
rainbow RC25-1RA	rainbow 25-pin to M-LNCS, Patient Cable, Right Angle, 1 foot/0.35 m	
RAM Dual RED 25 LNC-10	rainbow 25-pin to LNCS and RAS, Patient Cable, Straight, 10 feet/3.04 m	
RAM Dual RC25-10	rainbow 25-pin to M-LNCS and RAS, Patient Cable, Straight, 10 feet/3.04 m	989803182431

Temperature Accessories

Reusable Temperature Probes	Part No.	Minimum measurement time for accurate readings
General purpose probe	21075A	90 sec
Small flexible vinyl probe (Infant/Pediatric)	21076A	60 sec
Attachable surface probe	21078A	60 sec

Disposable Temperature Probes	Part No.	Minimum measurement time for accurate readings
General purpose probe	M1837A	90 sec
Skin probe	21091A	60 sec
Esophageal/Stethoscope Probe, 12 Fr	21093A	180 sec
Esophageal/Stethoscope Probe, 18 Fr	21094A	210 sec
Esophageal/Stethoscope Probe, 24 Fr	21095A	310 sec
Esophageal/Rectal Probe, 12 Fr	21090A	90 sec
Foley Catheter Probe, 12 Fr	M2255A	180 sec
Foley Catheter Probe, 16 Fr	21096A	180 sec
Foley Catheter Probe, 18 Fr	21097A	180 sec
Adapter cable, 1.5 m	21082B	--
Adapter cable, 3.0 m	21082A	--

Tympanic Temperature Accessories

Description	Part No.
Temperature probe	989803180831
Disposable probe cover with CE marking (22 boxes each containing 96 covers)	989803179611
Disposable probe cover (22 boxes each containing 96 covers)	989803179381
Cable RJ45 1.5m	M8081-61001
Cable RJ45 3 m	M8081-61002
Cable MP5 (connecting base station with the monitor)	453564373311

Cardiac Output (C.O.) Accessories

See "Invasive Pressure Accessories" on page 449 for PULSION continuous cardiac output accessories.

Accessories common to both methods		Part No.
Accessories	Set of ice buckets	14455A
PiCCO inline temperature probe	not made with natural rubber latex	M1646A

Right Heart Thermodilution		Part No.
C.O. Interface Cables	2.7 meter cable	M1642A
	2.4 m + 2.4 m cable	M1643A
Right heart catheter for thermodilution	(from Edwards Lifesciences)	831HF75
Edwards CO-Set+ (only with 23001A/B)	contact Edwards Lifesciences for information	
Injectate Probes	2.4 m injectate temp. probe (reusable)	23001A
	0.5 m injectate temp. probe (reusable)	23001B
	Ice bath temp. probe	23002A

Transpulmonary Thermodilution		Part No.
C.O. Interface Cables	2.4 m + 2.4 m cable	M1643A
PULSION Pressure Transducer Kits (pressure line available in various lengths)	Contact PULSION for information	
Pressure Interface Cable for disposable pressure transducer	PULSION PMK 206	

Mainstream CO2 Accessories

Description	Part No.
CO ₂ Sensor	M2501A
Adult/Pediatric Airway Adapter (reusable)	M2513A
Infant Airway Adapter (reusable)	M2516A
Adult Airway Adapter (single-patient use)	M2533A
Infant Airway Adapter (single-patient use)	M2536A

Sidestream CO2 Accessories

Description	Part No.
CO ₂ Sensor	M2741A
Gas Exhaust Tubing	M1015-40001

Nasal and Oral-Nasal Cannulas	Part No.
CO ₂ Nasal Cannula, Adult	M2744A
CO ₂ Nasal Cannula, Pediatric	M2745A
CO ₂ Nasal Cannula, Infant	M2746A
CO ₂ /O ₂ Nasal Cannula, Adult	M2750A
CO ₂ /O ₂ Nasal Cannula, Pediatric	M2751A
CO ₂ /O ₂ Nasal Cannula, Infant	989803144471
CO ₂ Oral-Nasal Cannula, Adult	M2756A
CO ₂ Oral-Nasal Cannula, Pediatric	M2757A
CO ₂ /O ₂ Oral-Nasal Cannula, Adult	M2760A
CO ₂ /O ₂ Oral-Nasal Cannula, Pediatric	M2761A

Airway Adapters	Part No.
Airway Adapter Set, ET > 4.0 mm	M2768A
Airway Adapter Set, ET ≤ 4.0 mm	989803144531
Airway Adapter Set H, ET > 4.0 mm	M2772A
Airway Adapter Set H, ET ≤ 4.0 mm	M2773A

Straight Sample Lines	Part No.
Straight Sample Line	M2776A
Straight Sample Line H	M2777A

Microstream CO₂ Accessories

- "FilterLine Set" is a combination of a FilterLine with an Airway Adapter.
- "H" in the accessory name indicates suitability for humidified ventilation and longer usage due to the active removal of humidity from the sample line.
- "Smart CapnoLine" is a combined oral-nasal FilterLine.
- "Smart CapnoLine O₂" is a combined oral-nasal-O₂-CO₂ FilterLine.
- "NIV Line" is a nasal FilterLine suitable for mask ventilation (for example, C-PAP).
- The accessories are supplied in packs of 25.

NOTE

Not all accessories are available in all countries.

Accessories for Intubated Patients	Part No.	Part Number for Long Version
FilterLine® SET Adult/Pediatric	M1920A	989803160241
FilterLine® H SET Adult/Pediatric	M1921A	989803160251
FilterLine® H SET Infant/Neonatal	M1923A	989803160261

Accessories for Intubated Patients	Part No.	Part Number for Long Version
VitaLine™ H SET Adult/Pediatric	989803159571	
VitaLine™ H SET Infant/Neonate	989803159581	

Accessories for Non-Intubated Patients	Part No.	Part Number for Long Version
CapnoLine® H Adult	M4689A	
CapnoLine® H Pediatric	M4690A	
CapnoLine® H Infant/Neonatal	M4691A	989803178011
CapnoLine® H O ₂ Adult	M4680A	
CapnoLine® H O ₂ Pediatric	M4681A	
CapnoLine® H O ₂ Infant/Neonatal	989803178001	
NIV Line™ Adult	M4686A	
NIV Line™ Pediatric	M4687A	
Nasal FilterLine® Infant/Neonatal	989803178021	
Nasal Filterline® O ₂ Adult	989803179101	989803179111
Nasal Filterline® O ₂ Pediatric	989803179121	
Smart CapnoLine® O ₂ Adult	M2522A	989803160281
Smart CapnoLine® H O ₂ Adult	989803177951	989803177961
Smart CapnoLine® O ₂ Pediatric	M2520A	989803160271
Smart CapnoLine® H O ₂ Pediatric	989803177971	989803177981
Smart CapnoLine® Adult	M2526A	989803160301
Smart CapnoLine® Pediatric	M2524A	

Accessories for Endoscopic Procedures	Part No.	Part Number for Long Version
Smart CapnoLine® Guard	989803178031	
Smart CapnoLine® Guard O ₂	989803178041	989803178051
Hook and Loop Strap	989803178071	

Miscellaneous Accessories	Part Number
Gas Exhaust Tubing	M1015-40001

G7m Gas Analyzer Accessories

Description	Part No.
Elbow Airway Adapter (single-patient use)	13902A
Straight Airway Adapter (single-patient use)	M1612A
Gas Exhaust Return Line (multi-patient use)	M1655B

Description	Part No.
Gas Exhaust Return Filter (single-patient use)	M1656B
Water trap (multi-patient use)	989803191081
Gas Sample Tube (2.6 m) (single patient use)	M1658A

EEG Accessories

WARNING

Use only Philips approved accessories to reduce the risk of burns and to prevent damage to the module or monitor resulting from defibrillation of the patient.

Description	Part No.
2 Channel Trunk Cable 2.7 m	M2268A
4 Channel Trunk Cable 2.7 m	989803180541
Reusable 80-cm-long 5-lead cables with 10 mm silver/silverchloride lead-wired cup electrodes (Adult)	M1931A
Reusable 80-cm-long 9-lead cables with 10 mm silver/silverchloride lead-wired cup electrodes (Adult)	989803180561
Reusable 80 cm 5-lead cables with 6 mm silver/silverchloride lead-wired cup electrodes (Pediatric/Neonatal)	M1932A
Reusable 80 cm 9-lead cables with 6 mm silver/silverchloride lead-wired cup electrodes (Pediatric/Neonatal)	989803180521
Reusable 80 cm 5-lead cables with clip	M1934A
Reusable 80 cm 9-lead cables with clip	989803180531
100 disposable EEG electrodes, wet gel, foam, 40 mm diameter	M1935A
300 disposable electrodes, solid gel, cloth, 22 x 22 mm	13955C
300 disposable electrodes, solid gel, cloth, 22 x 33 mm	13951C
EC2™ Electrode Cream (conductive paste)	M1937A

BIS Accessories

To re-order sensors, contact Medtronic. BIS sensors are not available from Philips.

SO2 Accessories

Contact your local PULSION or Edwards representative for information on accessories. They are not available from Philips.

Description	Product Number (Order Number)
Philips SO ₂ Optical Module	989803151591
Pulsion: CeVOX Fiberoptic Probe family (ScvO ₂)	Contact PULSION for part numbers of compatible probes
Edwards: Philips-compatible versions of the PreSep Catheter (ScvO ₂) or Swan-Ganz Oximetry Catheter (SvO ₂) families	Contact Edwards for part numbers of compatible catheters

NMT Accessories

Description	Product Number (Order Number)
IntelliVue NMT Patient Cable (reusable)	989803174581
NMT Hand Adapter (reusable)	989803199211

Recorder Accessories

For the M1116B recorder	Part No.
10 rolls of paper	40477A
80 rolls of paper	40477B

For the integrated recorder (MX400/MX450) and the M1116C recorder	Part No.
10 rolls of paper	M4816A
80 rolls of paper	M4817A

Specifications

The specifications in this section apply to the MX750/MX850.

The monitors are not user installable. They must be installed by qualified service personnel.

Indications for Use

The monitors are indicated for use by health care professionals whenever there is a need for monitoring the physiological parameters of patients.

The monitors are intended to be used for monitoring and recording of, and to generate alarms for, multiple physiological parameters of adults, pediatrics, and neonates. The monitors are intended for use by trained healthcare professionals in a hospital environment.

The monitors are only for use on one patient at a time. They are not intended for home use. Not therapeutic devices. The monitors are for prescription use only.

The ECG measurement is intended to be used for diagnostic recording of rhythm and detailed morphology of complex cardiac complexes (according to AAMI EC 11).

ST segment monitoring is intended for use with adult patients only and is not clinically validated for use with neonatal and pediatric patients.

BIS is intended for use under the direct supervision of a licensed health care practitioner or by personnel trained in its proper use. It is intended for use on adult and pediatric patients within a hospital or medical facility providing patient care to monitor the state of the brain by data acquisition of EEG signals. The BIS may be used as an aid in monitoring the effects of certain anesthetic agents. Use of BIS monitoring to help guide anesthetic administration may be associated with the reduction of the incidence of awareness with recall in adults during general anesthesia and sedation.

The SSC Sepsis Protocol, in the ProtocolWatch clinical decision support tool, is intended for use with adult patients only.

The Integrated Pulmonary Index (IPI) is intended for use with adult and pediatric (1 to 12 years) patients only. The IPI is an adjunct to and not intended to replace vital sign monitoring.

The derived measurement Pulse Pressure Variation (PPV) is intended for use with sedated patients receiving controlled mechanical ventilation and mainly free from cardiac arrhythmia. The PPV measurement has been validated only for adult patients.

The IntelliVue NMT Module is intended to be used as an objective neuromuscular transmission monitor, using accelerometry for measuring the muscle contraction following an electrical stimulation of a peripheral nerve. The NMT Module is intended to be used with adult and pediatric patients.

The Masimo rainbow SET measurement is indicated for the noninvasive monitoring of functional oxygen saturation of arterial hemoglobin (SpO₂), pulse rate, carboxyhemoglobin saturation (SpCO), methemoglobin saturation (SpMet), total hemoglobin concentration (SpHb), and/or respiratory rate (RRac). The Masimo rainbow SET measurement is indicated for use during both no motion and motion conditions, and for patients who are well or poorly perfused.

Use Environment

Hospital Environment

The monitors are suitable for use in all medically used rooms which fulfill the requirements regarding electrical installation according to IEC 60364-7-710 "Requirements for special installations or locations - Medical locations", or corresponding local regulations.

WARNING

The monitors are not intended for use in an MRI environment or in an oxygen-enriched environment (for example, hyperbaric chambers).

Physical Security and Limited Access to the Monitor

Access to the monitor must be limited to authorized users. It is important that you consider physical security measures to ensure that unauthorized users cannot gain access.

Manufacturer's Information

You can write to **Philips** at this address:

Philips Medizin Systeme Boeblingen GmbH
Hewlett-Packard-Str. 2
71034 Boeblingen
Germany

Visit our website at: www.healthcare.philips.com

© Copyright 2019. Koninklijke Philips N.V. All Rights Reserved.

Australia Sponsor

Philips Electronics Australia Ltd
65 Epping Road
North Ryde, NSW Australia 2113

BIS Manufacturer's Information

The BIS device, the Patient Interface Cable and the BIS Sensor are manufactured by Covidien:

Covidien llc
15 Hampshire Street
Mansfield, MA 02048
USA

Trademark and License Acknowledgments

PiCCO™ is a trademark of PULSION Medical Systems AG.

Bispectral Index and BIS are trademarks of a Medtronic company and are registered in the USA, EU and other countries.

Microstream®, FilterLine®, and Smart CapnoLine® are trademarks or registered trademarks of Oridion Systems Ltd.

Citrix®, Citrix Receiver™, XenApp®, and ICA® are trademarks of Citrix Systems, Inc. and/or one or more of its subsidiaries, and may be registered in the United States Patent and Trademark Office and in other countries.

ACCESS™ and NetFront™ are registered trademarks or trademarks of ACCESS CO., LTD. in the United States, Japan and/or other countries.

The following are trademarks and registered trademarks of a Medtronic company: Nellcor, Durasensor, Dura-Y, Oxiband, Oxicliq, OxiMax, MAX-FAST, and Softcare.

The following are registered trademarks of Masimo Corporation: DCI, FastSat, LNCS, LNOP, Masimo, PVI, SET, SpCO, SpHb, SpMet, TF-I, rainbow ReSposable, APOD, rainbow. The following are trademarks of Masimo Corporation: M-LNCS, rainbow Acoustic Monitoring, rainbow Acoustic Sensor, rainbow Acoustic.

Other product and company names mentioned in this book may be trademarks of their respective owners.

The monitors use Open Source Software. For details check the license screen via **Main Setup, Revisions, OSS Licenses**.

Installation Safety Information

WARNING

If multiple instruments are connected to a patient, the sum of the leakage currents may exceed the limits given in:







- IEC/EN 60601-1
- ANSI/AAMI ES60601-1
- CAN/CSA C22.2 No. 60601-1:14

Consult your service personnel.



































Grounding	The monitor must be grounded during operation. If a three-wire receptacle is not available, consult the hospital electrician. Never use a three-wire to two-wire adapter.
Equipotential Grounding	If the monitor is used in internal examinations on the heart or brain, ensure that the room incorporates an equipotential grounding system to which the monitor has a separate connection.
Combining equipment	Combinations of medical equipment with non-medical equipment must comply with IEC 60601-1-1. Never use a multiple portable socket-outlet or extension cord when combining equipment unless the socket outlet is supplied specifically for use with that equipment.
Fusing	The monitor uses double fusing (line and neutral).























Symbols

These symbols can appear on the monitor and its associated equipment and packaging.

Symbols			
	Caution, is necessary when operating the device.		Operating instructions should be considered when operating the device.
	Follow instructions for use.		Quick mount release
	Equipotential grounding		Protective earth

38 Specifications

Symbols			
	Connector has special protection against electric shocks and is defibrillator proof (Type CF according to IEC 60601-1)		Applied part has special protection against electric shocks (Type BF according to IEC 60601-1) and is defibrillator proof
	Start a measurement		Stop a measurement
	Standby		Module Rack power-on indicator
	Error LED		Alternating current
	Connection direction indicator		Connection direction indicator
	Electrical input indicator (In some cases gas input indicator)		Electrical output indicator (In some cases gas output indicator)
	Gas input indicator		Gas output indicator
	Data input/output symbol		USB interface
	Manufacturer's name and address		Identifies date of manufacture
	Non-ionizing radiation symbol		Always use separate collection for waste electrical and electronic equipment (WEEE)
	Pressure connector		NBP connector
	Cardiac Output connector		SpO ₂ connector
	Temperature connector		Monitor supports 12-lead ECG
	Masimo SET technology		Nellcor OxiMax compatible
	Masimo rainbow SET technology		Uses FAST SpO ₂ algorithm
	Alarms Switched Off		Acknowledge Alarms
	Alarms On/Off		Main Screen

Symbols			
	SmartKeys		Back key
	Enter the measurement setup menu		Purge flow tubing with air and perform automatic zero calibration
	Zero the invasive pressure transducer		ECG Sync Output/ Analog ECG Output
	Enter the measurement setup menu to start a calibration	IP	Followed by two alphanumeric characters, indicates ingress protection grade
REF	Indicates location of catalog number	SERVICE#	Indicates location of service number
	Mass in kilogram (kg)		Rechargeable battery symbol
	Battery LED		Indication for battery placement in battery compartment
Setup	Label for the setup key, used to enter the measurement setup menu	LOT	Indicates location of batch number.
	Indicates the location of the "use by" date.	Rx only	Prescription use only
LATEX	Not made with natural rubber latex		Contents of the packaging are not sterile.
	Atmospheric pressure limitations for storage		Humidity limitations for storage
	Temperature limitations for storage	SN	Indicates location of serial number
	NFC Reader		
CE ₀₁₂₃	CE mark accompanied by the Notified Body number 0123 (EU compulsory product compliance mark used for medical devices)		Indicates that the product was tested and has met the CSA certification requirements for Canada and the US
EAC	Customs Union EAC Qualification Certification (Customs Union established by Russia, Belarus and Kazakhstan)		China RoHS mark
	RCM certification mark (Australian Communications Product Certification)		An information sign or warning sign that is part of the CE mark and is used to inform the user of the restrictions on the use of the device.
CE	CE Mark (EU compulsory product compliance mark)		Japan TELEC wireless certification mark

Connectors

The actual placement of boards and configuration of connections for your monitor depends on how your hardware has been configured. See the symbols table (“Symbols” on page 469) to see which symbols are used to mark the connections.

WARNING

Connect only medical devices to the ECG output connector socket.

MX750/850

Rear of the Monitor

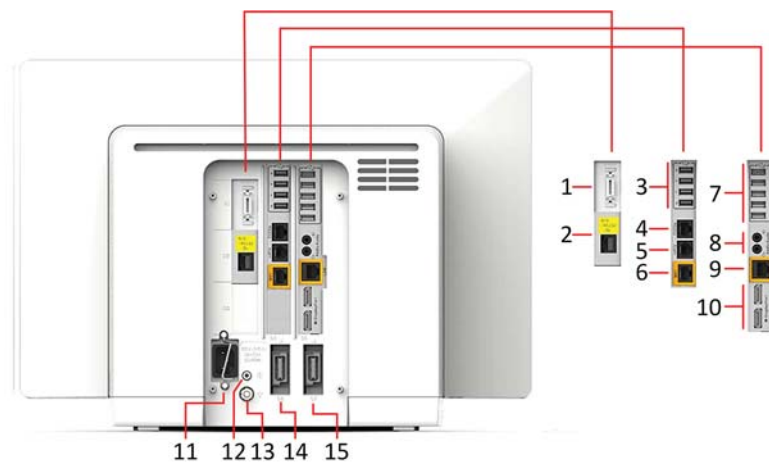

Number	Description
1/2	Flexible Nurse Call, Serial/MIB (RS232) connectors
3	USB rear connectors (for keyboard, pointing devices, printer)
4	Serial RS232 connector
5	Nurse Call
6	Wired network connector
7-10 are only present with the iPC	
7	USB rear connectors
8	Audio in/out
9	Local Area Network
10	Two independent Video out connectors (DisplayPort)
11	AC power input
12	Protective earth screw hole
13	Equipotential ground connector
14	Main measurement link (MSL)
15	Additional measurement link (MSL) MX850 Only

Left Side of the Monitor



- 1 ECG Sync Output/Analog ECG output connector

Right Side of the Monitor



- 1 USB side connector (only present with the iPC)

Monitor Mounting Precautions

Mount the monitor using either the Philips Quick Mount or Fix Mount solution or another approved mounting solution. Select the mounting equipment and the mounting position so that no patient, operator or other person can be harmed by a monitor removed intentionally or released accidentally from the mount. When using the Quick Mount, be aware of the danger of accidental activation of the Quick Mount release button when lifting or moving items located under the monitor, such as pole mounts, etc. If in doubt, use the Philips Fix Mount solution to avoid such situations. Refer to the respective IntelliVue Monitor Service Guide, Installation Instructions chapter, for more details.

Always ensure that the monitor is positioned so that the AC power plug is easily accessible, to allow disconnection of the monitor from the AC power source.

Repositioning a Monitor on the Mounting Arm

Attempts to reposition the monitor should only be performed as described in the mounting hardware manufacturer's user documentation. If the mounting arm has a locking mechanism, ensure the locking mechanism is unlocked before attempting to reposition the monitor. Never pull on the monitor to tilt, swivel or otherwise reposition it - always hold on to the mounting hardware itself.

WARNING

Not adhering to these instructions when repositioning the monitor can cause damage to the monitor. In extreme cases, when force is applied to the monitor, it can result in the monitor falling from the mounting arm.

If, at any time, the monitor appears to be loose or insecurely mounted, contact your service personnel.

Altitude Setting

Altitude and barometric pressure affect tcGas, CO₂ and Gas Analyzer measurements. The monitor must be configured at installation to the correct altitude corresponding to the correct barometric pressure values for your hospital site.

The gas analyzer module measures the barometric pressure continuously. If the barometric pressure measured by the gas analyzer module differs by more than 60 mmHg from the monitor settings a **Zero Failed INOP** is issued to indicate that either the altitude setting is incorrect or the pressure sensor is defective. In the latter case, the conversions from concentration (vol%) to partial pressure (mmHg, kPa) may be incorrect.

Monitor Safety Specifications



The monitors, together with the Multi-Measurement Modules (867030/867036), the Module Rack FMX-4 (866468), the current generation Measurement Extensions (867039, 867040, 867041), the Base Station of the Tympanic Thermometer (866149), and a selection of modules (see below) comply with the Medical Device Directive 93/42/EEC. Compliant modules are Pressure (M1006B), SO₂ (M1011A), C.O. (M1012A), SpO₂ (M1020B #A01), EEG (M1027B), Temperature (M1029A), BIS Interface (M1034B), Recorder (M1116C), IntelliBridge EC10/EC5 (865115/865114), NMT (865383), and G7m Gas (866173).

In addition, the products comply with:

IEC 60601-1, Ed .3.1:2012-08 (cons.) / EN 60601-1:2006 + AC:2010 + A1:2013, Ed. 3
ANSI/AAMI ES60601-1:2005/(R)2012, Ed. 3 (cons.)
CAN/CSA-C22.2 No. 60601-1:14, Ed. 3 (cons.)
IEC 60601-1-6:2010 + A1:2013 / EN 60601-1-6:2010 + A1:2015
IEC 60601-1-8:2006 + A1:2012 / EN 60601-1-8:2007 + A1:2013 + AC:2014
IEC 80601-2-49:2018/EN 60601-2-49:2015
IEC 60601-1-2:2014 / EN 60601-1-2:2015

The possibility of hazards arising from software errors was minimized in compliance with:

ISO 14971:2007 / EN ISO 14971:2012

IEC 62304:2006 + A1:2015/ EN 62304:2006 + AC:2008 + A1:2015

Classification (according to IEC 60601-1): Class 1, Type CF, Continuous Operation. The BIS, NMT, and tympanic temperature measurements, and the G7m gas analyzer use a Type BF applied part.

Physical Specifications

Product	Maximum Weight	W x H x D	Comments
MX850 Monitor	11 kg (24.3 lb)	544 x 388 x 217 mm (21.4 x 15.3 x 8.5 in)	with cable management
MX750 Monitor	10 kg (22 lb)	477 x 350 x 217 mm (18.8 x 13.8 x 8.5 in)	with cable management
867036 Multi-Measurement Module (MMX)	1 kg (2.2 lb)	188.3 x 97.1 x 58 mm (7.4 x 3.8 x 2.3 in)	
M3001A/M3001AL Multi-Measurement Module (MMS)	0.6 kg (1.4 lb)	189 x 98 x 57 mm (7.4 x 3.9 x 2.2 in)	
M3002A X2 Multi-Measurement Module	1.2 kg (2.6 lb)	189 x 99 x 89 mm (7.4 x 3.9 x 3.5 in)	including battery, without handle or options
		199 x 146 x 89 mm (7.8 x 5.7 x 3.5 in)	including battery, with handle
867030 X3 Multi-Measurement Module	1.4 kg (3.1 lbs)	249 x 97 x 111 mm (9.8 x 3.8 x 4.4 in)	including battery and options, with handle
		194 x 97 x 85 mm (7.6 x 3.8 x 3.3 in)	including battery and options, without handle

38 Specifications

Product	Maximum Weight	W x H x D	Comments
867039 Hemodynamic Extension	0.5 kg (1.1 lbs)	200 x 97 x 90 mm (7.9 x 3.8 x 3.5 in)	
867040 Capnography Extension	0.5 kg (1.1 lbs)	200 x 97 x 90 mm (7.9 x 3.8 x 3.5 in)	
867041 Microstream Extension	0.6 kg (1.4 lbs)	200 x 97 x 90 mm (7.9 x 3.8 x 3.5 in)	
M3012A Hemodynamic Extension	0.6 kg (1.4 lb)	200 x 98 x 89 mm (7.9 x 3.9 x 3.5 in)	
M3014A Capnography Extension	0.6 kg (1.4 lb)	200 x 98 x 89 mm (7.9 x 3.9 x 3.5 in)	
M3015A/B Microstream CO ₂ Extension	0.6 kg (1.4 lb)	202 x 98 x 89 mm (7.9 x 3.9 x 3.5 in)	
866468 4-Slot Module Rack (FMX)	0.95 kg (2.1 lb)	194 x 139 x 110 mm (7.6 x 5.5 x 4.3 in)	without plug-in modules and without Multi-Measurement Module Mount
	1.1 kg (2.4 lb)	232 x 139 x 188 mm (9.1 x 5.5 x 7.4 in)	with Multi-Measurement Module Mount
M1006B Invasive Press Module	0.3 kg (0.7 lb)	36 x 102 x 111 mm (1.4 x 4.0 x 4.4 in)	Specifications are also valid for Opt. C01.
M1029A Temperature Module	0.3 kg (0.7 lb)	36 x 102x 111 mm (1.4 x 4.0 x 4.4 in)	
M1012A Cardiac Output Module	0.3 kg (0.7 lb)	36 x 102 x 111 mm (1.4 x 4.0 x 4.4 in)	Specifications are also valid for Opt. C10.
M1020B SpO ₂ Module	0.3 kg (0.7 lb)	36 x 102 x 111 mm (1.4 x 4.0 x 4.4 in)	
M1011A SO ₂ Module	0.3 kg (0.7 lb)	36 x 102 x 111 mm (1.4 x 4.0 x 4.4 in)	
SO ₂ Optical Module	0.2 kg (0.4 lb)	50 x 30 x 120 mm (2.0 x 1.2 x 4.7 in)	including 2.9 m cable
M1027B Electroencephalograph Module	0.3 kg (0.7 lb)	36 x 102 x 111 mm 1.4 x 4.0 x 4.4 in)	
M1034B BIS Module	0.3 kg (0.7 lb)	36 x 102 x 111 mm (1.4 x 4.0 x 4.4 in)	without cables
BIS Device	0.5 kg (1.1 lb)	diameter x height: 95.3 x 63.5 mm (3.8 x 2.5 in)	with Patient Interface Cable (1.22 m, 4 ft) and cable to BIS module
865115 IntelliBridge EC10 Module	0.3 kg (0.7 lb)	36 x 102 x 111 mm (1.4 x 4.0 x 4.4 in)	
865114 IntelliBridge EC5 Module	0.03 kg (0.07 lb)	35 x 17 x 57 mm (1.4 x 0.7 x 2.1 in)	with D-Sub 9-pin male or female connector
	0.02 kg (0.04 lb)	21.5 x 17 x 65 mm (0.9 x 0.7 x 2.6 in)	without cable and strain relief
M1116C Thermal Array Recorder Module	0.5 kg (1.1 lb)	73 x 102 x 111 mm (2.9 x 4.0 x 4.4 in)	
865383 IntelliVue NMT Module	0.3 kg (0.7 lb)	36 x 102 x 111 mm (1.4 x 4.0 x 4.4 in)	without cables
866173 IntelliVue G7m Gas Analyzer Module	1 kg (2.2 lb)	72 x 101 x 157 mm (2.8 x 4.0 x 6.2 in)	

Environmental Specifications

The monitor may not meet the performance specifications given here if stored or used outside the specified temperature and humidity ranges.

When the monitor and related products have differing environmental specifications, the effective range for the combined products is that range which is common to the specifications for all products.

MX750/850 Monitor

Item	Condition	Range
Temperature Range	Operating	0 to 40°C (32 to 100°F) 0 to 35°C (32 to 95°F) when equipped with the iPC
	Storage	-20 to 60°C (-4 to 140°F)
Humidity Range	Operating	15% to 95% Relative Humidity (RH) (non condensing)
	Storage	5% to 95% Relative Humidity (RH)
Altitude Range	Operating	-500 m to 3000 m (-1600 to 10000 ft)
	Storage	-500 m to 4600 m (-1600 to 15000 ft) ¹
Ingress Protection		IP21
Definition of IP codes used:		
IP21	Protected against harmful effects of vertically dripping water and ingress of foreign objects larger than 12.5 mm	

¹ Sufficient for flight altitudes up to 12000 m with pressurized cabins

X2 (M3002A)

Item	Condition	Range
Temperature Range	Operating	0 to 40°C (32 to 104°F) 0 to 35°C (32 to 95°F) when charging the battery or when equipped with IntelliVue Instrument Telemetry or the IntelliVue 802.11 Bedside Adapter
	Storage including transportation	-20 to 60°C (-4 to 140°F)
Humidity Range	Operating	15% to 95% Relative Humidity (RH)
	Storage including transportation	5% to 95% Relative Humidity (RH)
Altitude Range	Operating	-500 m to 3000 m (-1600 to 10000 ft)
	Storage including transportation	-500 m to 4600 m (-1600 to 15000 ft) ¹
Ingress Protection		IP32
Definition of IP codes used:		
IP32	Protected against ingress of water when the water is dripping vertically and the monitor is tilted up to 15°, and ingress of solid foreign objects 2.5 mm in diameter or larger.	

¹ Sufficient for flight altitudes up to 12000 m with pressurized cabins

X3 (867030), MMX (867036) and Measurement Extensions (867039, 867040, 867041)

Item	Condition	Range
Temperature Range	Operating	0 to 40°C (32 to 104°F)
	Operating when charging the battery, when equipped with wireless LAN or IntelliVue Instrument Telemetry Wireless network, or when X3 is mounted directly on a host monitor	0 to 35°C (32 to 95°F)
	Storage including transportation	-20 to 60°C (-4 to 140°F)
Humidity Range	Operating	15% to 95% Relative Humidity (RH)
	Storage including transportation	5% to 90% Relative Humidity (RH)
Altitude Range	Operating	-500 m to 3000 m (-1600 ft to 10000 ft)
	Storage including transportation	-500 m to 4600 m (-1600 ft to 15000 ft) ¹
Ingress Protection	867030 IntelliVue X3	IP32 when mounted horizontally
	867036 MMX	IP32 when mounted horizontally
	867039 Hemodynamic Extension	IP32 when mounted horizontally
	867040 Capnography Extension	IP32 when mounted horizontally
	867041 Microstream CO ₂ Extension	IP32 when mounted horizontally
Definition of IP codes used:		
IP32	Protected against ingress of water when the water is dripping vertically and the monitor is tilted up to 15°, and ingress of solid foreign objects 2.5 mm in diameter or larger.	

¹ Sufficient for flight altitudes up to 12000 m with pressurized cabins

FMX-4 Module Rack (866468)

4-Slot Module Rack 866468		
Item	Condition	Range
Temperature Range	Operating	0 to 40°C (32 to 100°F)
	Storage	-20 to 60°C (-4 to 140°F)
Humidity Range	Operating	15% to 95% Relative Humidity (RH) (non condensing)
	Storage	5% to 95% Relative Humidity (RH)
Altitude Range	Operating	-500 m to 3000 m (-1600 to 10000 ft)
	Storage	-500 m to 4600 m (-1600 to 15000 ft)
Ingress Protection		IP21
Definition of IP codes used:		
IP21	Protected against harmful effects of vertically dripping water and ingress of foreign objects larger than 12.5 mm	

MMS (M3001A/M3001AL), Measurement Extensions (M3012A, M3014A, M3015A/B) and Measurement Modules

Multi-Measurement Module M3001A/M3001AL, Measurement Extensions M3012A, M3014A, M3015A/B, and Measurement Modules		
Item	Condition	Range
Temperature Range	Operating	0 to 45°C (32 to 113°F)
	Non-operating	-40 to 70°C (-40 to 158°F)
Humidity Range	Operating	95% Relative Humidity (RH) max. @ 40°C (104°F). M3015A/B only non-condensing.
	Non-operating	90% Relative Humidity (RH) max. @ 65°C (150°F)
Altitude Range	Operating	-500 m to 4600 m (-1600 to 15000 ft)
	Non-operating	-500 m to 15300 m (-1600 to 50000 ft)

Ingress Protection for MMS M3001A/M3001AL Measurement Extensions M3014A, M3015A/B, and Module M1020B		
Ingress Protection	M3001A/M3001AL	IP32
	M3014A, M3015A/B and M1020B	IPX1
Definition of IP codes used:		
IP32	Protected against harmful effects of vertically dripping water with the device tilted at any angle up to 15° and ingress of foreign objects larger than 2.5 mm	
IPX1	Protected against harmful effects of vertically dripping water	

G7m Gas Analyzer Module (866173)

Item	Condition	Range
Temperature Range	Operating	10 to 40°C (50 to 104°F)
	Non-operating	-20 to 60°C (-4 to 140°F)
Humidity Range	Operating	5 to 95% RH up to 40°C (104°F) non-condensing
	Non-operating	5 to 95% non condensing
Altitude Range	Operating/non-operating	-500 to 4750 m (-1640 to 15584 ft)
Ingress Protection	IP31	
Definition of IP codes used:		
IP31	Protected against harmful effects of vertically dripping water and ingress of foreign objects larger than 2.5 mm	

Thermal Array Recorder Module M1116B/C

Item	Condition	Range
Temperature Range	Operating	+5 to 45°C (41 to 113°F)
	Non-operating	-10 to 70°C (14 to 158°F)

Item	Condition	Range
Humidity Range	Operating	95% Relative Humidity (RH) max. @ 40°C (104°F) (non condensing)
	Non-operating	90% Relative Humidity (RH) max. @ 65°C (150°F) (non condensing)
Altitude Range	Operating	up to 3048 m (10000 ft)
	Non-operating	up to 3048 m (10000 ft)

EMC and Radio Regulatory Compliance

This ISM device complies with Canadian ICES-001. Cet appareil ISM est conforme à la norme NMB-001 du Canada.

IntelliVue 802.11 Bedside Adapter (Option J35 Wireless Network Adapter)

FCC and Industry Canada Radio Compliance: This device complies with Part 15 of the FCC Rules and RSS-247 of Industry Canada. Operation is subject to the following two conditions: (1) this device may not cause harmful interference, and (2) this device must accept any interference received, including interference that may cause undesired operation. Any changes or modifications to this equipment not expressly approved by Philips Medical Systems may cause harmful radiofrequency interference and void your authority to operate this equipment.

The maximum antenna gain permitted (for devices in the 5250-5350 MHz and 5470-5725 MHz bands) complies with the e.i.r.p. limits as stated in RSS-247.

The maximum antenna gain permitted (for devices in the 5725-5825 MHz band) complies with the e.i.r.p. limits specified for point-to-point operation, as stated in RSS-247.

The device for the band 5150-5350 MHz is only for indoor usage to reduce potential for harmful interference to co-channel mobile satellite systems.

CAUTION

High power radars are allocated as primary users (meaning they have priority) of 5250-5350 MHz and 5650-5850 MHz and these radars could cause interference and /or damage to license-exempt local area network (LE-LAN) devices.

IntelliVue 802.11 Bedside Adapter CE compliances:

This radio equipment is in compliance with the essential requirements and other relevant provisions of Directive 2014/53/EU (Radio Equipment Directive).

NFC (Near Field Communication) Interface

FCC and Industry Canada Radio Compliance: This device complies with Part 15 of the FCC Rules and RSS-247 of Industry Canada. Operation is subject to the following two conditions: (1) this device may not cause harmful interference, and (2) this device must accept any interference received, including interference that may cause undesired operation. Any changes or modifications to this equipment not expressly approved by Philips Medical Systems may cause harmful radiofrequency interference and void your authority to operate this equipment.

Monitor Performance Specifications

MX750/850 Performance Specifications

MX750/850 Performance Specifications		
Power Specifications	Power Consumption	<200 W average
	Line Voltage	100 to 240 V
	Current	1.9 to 0.9 A
	Frequency	50/60 Hz
Indicators	Alarms Off	red or yellow LED with crossed out alarms symbol
	Alarms	red/yellow/light blue (cyan) LED
	On/Error	green/red LED integrated in power switch
	External Power	green LED
Sounds	Audible feedback for user input Prompt tone QRS tone, or SpO ₂ modulation tone 3 different alarm priority sounds (low, medium, high) Remote tone for alarms on other beds in network Tone for Timer expired	
Display Wave Speeds		6.25 mm/s, 12.5 mm/s, 25 mm/s, 50 mm/s with $\pm 5\%$ accuracy (guaranteed only for integrated displays)
Trends	Resolution	up to 96h for 100 numerics
	Information	Multiple choices of resolution and duration. Available options: 100 numerics for 4h @ 12sec, 24h @ 1min, 48h @ 5min 100 numerics for 8h @ 12sec, 48h @ 1min, 96h @ 5min
High Res Trend Waves	Measurements available	HR, SpO ₂ , Resp, tcpO ₂ , Pulse, Perf, tcpCO ₂ , CO ₂ , ABP, PAP, CVP, ICP, CPP, BIS, CCO, AWP, Anesthetic Agents, Delta SpO ₂ , inO ₂
	Resolution	Measurement samples are taken at a resolution of four samples per second
	Update speed	waves are drawn at a speed of 3 cm/minute
Events	Information	trigger condition and time, event classification and associated detailed view of episode data
	Episode data	configurable, either: 4 minutes of high resolution trend or 20 minutes of numerics trend @ 12 sec. resolution or 15 seconds of 4 waves @ 125 samples/sec. (Snapshot) including all current numerics, alarms and inops
	Capacity (max.)	25 or 50 events for either 8 or 24 hours

MX750/850 Performance Specifications		
Alarm Signal	System alarm delay The system alarm delay is the processing time the system needs for any alarm to be indicated on the monitor, after the measurement has triggered the alarm.	less than 4 seconds
	Delay for alarm availability on the network This is the time needed after alarm indication on the monitor until the alarm signal is available on the network, to the Information Center or for transmission to other systems.	less than 5 seconds
	Pause duration	1,2,3 minutes or infinite, depending on configuration
	Extended alarm pause	5 or 10 minutes
	Sound pressure range	min. 0 dB(A) max. 45-85 dB(A)
	Review Alarms	Information
Capacity		300 items
Real Time Clock	Range	from: January 1, 1997, 00:00 to: December 31, 2080, 23:59
	Accuracy	better than 4 seconds per day
	Hold Time	infinite if powered by AC; otherwise at least 48 hours
Buffered Memory	Hold Time	if powered by AC: infinite without power: at least 8 hours
	Contents	Active settings, trends, patient data, realtime reports, events, review alarms

X2 Performance Specifications

X2 (M3002A) Performance Specifications		
Power Specifications	Power consumption	<12 W average <30 W while battery is loading
	Operating Voltage	36 to 60 V DC floating
Battery Specifications	Operating Time (with new, fully charged battery at 25°C)	Basic monitoring configuration: 2.5 hours (Brightness set to optimum, ECG/Resp, SpO ₂ measurements in use, NBP measurement every 15 minutes)
	Charge Time	When X2 is off: 2 hours When X2 is in use, and connected to a monitor, without extensions: 12 hours approx. When X2 is in use, and connected to the external power supply (M8023A), without extensions: 12 hours approx.

X2 (M3002A) Performance Specifications		
Indicators	Alarms Off	red or yellow LED with crossed-out alarm symbol
	Alarms	red/yellow/light blue (cyan) LED
	On/Error	green / red LED
	AC Power	green LED
	Battery	yellow (charging)/red blinking (empty) LED
	External Power	green LED
Sounds		Audible feedback for user input Prompt tone QRS tone, or SpO ₂ modulation tone 4 different alarm sounds
Display Wave Speeds		6.25 mm/s, 12.5 mm/s, 25 mm/s, 50 mm/s with $\pm 5\%$ accuracy (guaranteed only for integrated displays)
Trends	Resolution	12 or 16 numerics @ 12 sec, 1 minute, 5 minute resolution.
	Information	Multiple choices of number of numerics, resolution and duration depending on trend option and application area. For example: For neonatal, you can choose between 12 and 16 numerics.
Alarm signal	System alarm delay	less than 4 seconds
	Pause duration	1,2,3 minutes or infinite, depending on configuration
	Extended alarm pause	5 or 10 minutes
Review Alarms	Information	all alarms / INOPs, main alarms on/off, alarm acknowledgment and time of occurrence
	Capacity	300 items
Real Time Clock	Range	from: January 1, 1997, 00:00 to: December 31, 2080, 23:59
	Accuracy	<4 seconds per day (typically)
	Hold Time	infinite if powered by host monitor or external power supply; otherwise at least 48 hours
Buffered Memory	Hold Time	if powered by host monitor or external power supply: infinite without power: at least 48 hours (typical: >72 hours)
	Contents	Active settings, trends, patient data, realtime reports, review alarms

X3 (867030) Performance Specifications

X3 (867030) Performance Specifications		
Power Specifications	Power consumption	<12 W average <15 W when on IntelliVue Dock
	Operating Voltage	36 to 60 V DC floating
Battery Specifications	Operating Time (with new, fully charged battery at 25°C)	Basic monitoring configuration: minimum 5 hours (Brightness set to Optimum (4), ECG/Resp, SpO₂, measurements in use, NBP measurement every 15 minutes)
	Charge Time	When X3 is switched off and connected to a host monitor, IntelliVue Dock, or the external power supply (M8023A): 3 hours approx. When X3 is in use, and connected to the external power supply (M8023A) or to an MX400-550 monitor, without Measurement Extensions: 3 hours approx. When X3 is in use, and connected to IntelliVue Dock, without Measurement Extensions: 2.5 hours approx.
Indicators	Alarms Off	red or yellow LED with crossed out alarms symbol
	Alarms	red/yellow/light blue (cyan) LED
	On/Error	green / red LED
	AC Power	green LED
	Battery	green (full)/yellow (charging)/red blinking (empty) LED
	External Power	green LED
Sounds	Audible feedback for user input Prompt tone QRS tone, or SpO ₂ modulation tone 4 different alarm sounds	
Display Wave Speeds		6.25 mm/s, 12.5 mm/s, 25 mm/s, 50 mm/s with ±5% accuracy (guaranteed only for integrated displays)
Trends	Resolution	12 or 16 numerics @ 12 sec, 1 minute, 5 minute resolution.
	Information	Multiple choices of number of numerics, resolution and duration depending on trend option and application area.
Alarm signal	System alarm delay The system alarm delay is the processing time the system needs for any alarm to be indicated on the monitor, after the measurement has triggered the alarm.	less than 4 seconds
	Delay for alarm availability on the network This is the time needed after alarm indication on the monitor until the alarm signal is available on the network, to the Information Center or for transmission to other systems.	less than 5 seconds
	Pause duration	1,2,3 minutes or infinite, depending on configuration
	Extended alarm pause	5 or 10 minutes
	Sound pressure range	min. 0 dB(A) max. 45-85 dB(A)

X3 (867030) Performance Specifications		
Review Alarms	Information	all alarms / INOPs, main alarms on/off, alarm acknowledgment and time of occurrence
	Capacity	300 items
Real Time Clock	Range	from: January 1, 1997, 00:00 to: December 31, 2080, 23:59
	Accuracy	<4 seconds per day
	Hold Time	<ul style="list-style-type: none"> • if powered by external power supply: infinite • with battery: time is stored but a hold time is not specified, as storing a battery in an unused device for a longer period of time is not recommended • without power or battery: at least 48 hours
Buffered Memory	Hold Time	<ul style="list-style-type: none"> • if powered by external power supply: infinite • with battery: memory is buffered but a hold time is not specified, as storing a battery in an unused device for a longer period of time is not recommended • without power or battery: at least 4 hours
	Contents	Active settings, trends, patient data, realtime reports, review alarms

MMX (867036) Performance Specifications

MMX (867036) Performance Specifications		
Trends	Resolution	12 or 16 numerics @ 12 sec, 1 minute, 5 minute resolution.
	Information	Multiple choices of number of numerics, resolution and duration depending on trend option and application area.
Real Time Clock	Range	from: January 1, 1997, 00:00 to: December 31, 2080, 23:59
	Accuracy	<4 seconds per day
	Hold Time	<ul style="list-style-type: none"> • if powered: infinite • without power: at least 8 hours
Buffered Memory	Hold Time	<ul style="list-style-type: none"> • if powered: infinite • without power: at least 10 hours
	Contents	Active settings, trends, patient data, realtime reports, review alarms

MMS M3001A/M3001AL Performance Specifications

M3001A/M3001AL MMS Performance Specifications		
Trends	Trend Data Buffered Memory	if powered by monitor mains connection via MSL: infinite without power applied: at least 6 hours
	Contents	trend data, patient identification and all active settings

Integrated PC (iPC)

Integrated PC (iPC) Performance Specifications		
PC Components	Processor	Intel Core i5-4300U
	Graphics	Intel HD Graphics 4400
	Solid-state drive	100 GB or above
	RAM	8 GB

Interface Specifications

MX750/850 Interface Specifications

MX750/850		
Network	Standard	IEEE802.3 10BASE-T and 100BASE-TX, auto negotiation, full and half-duplex, IEEE802.3af
	Connector	RJ45 (8 pin)
	Isolation	basic insulation (reference voltage: 250 V; test voltage: 1500 V)
MIB/RS232	Standard	ISO/IEC 11073-30200 compliant
	Connectors	RJ45 (8 pin)
	Mode	Software-controllable BCC (RxD/TxD cross over) or DCC (RxD/TxD straight through)
	Power	5 V \pm 5 %, 100 mA (max.)
	Isolation	basic insulation (reference voltage: 250 V; test voltage: 1500 V)
USB Interface	Standard	USB 2.0 full-speed (embedded host)
	Connector	USB series "Standard A" receptacle
	Power	Low power port 4.4V min; max. load for all ports together 500 mA
	Isolation	none
RS232 (Standard)	Connector	RJ45 (8-pin)
	Power	none
	Isolation	basic insulation (reference voltage: 250 V; test voltage: 1500 V)
Basic Nurse Call Relay	Connector	modular Jack 6P6C, active open and closed contact
	Contact	\leq 100 mA, \leq 24 V DC
	Isolation	basic insulation (reference voltage: 250 V; test voltage: 1500 V)
	Delay	$<$ [Configured Latency +0.5] sec
Flexible Nurse Call Relay	Connector	20 pin MDR (Mini D-Ribbon), active open and closed contacts
	Contact	\leq 100 mA, \leq 24 V DC
	Isolation	basic insulation (reference voltage: 250 V; test voltage: 1500 V)
	Delay	$<$ [Configured Latency +0.5] sec

MX750/850		
IntelliVue 802.11 Bedside Adapter (Wireless Network Adapter)	Type	Internal Wireless Adapter
	Technology	IEEE 802.11a/b/g/n
	Frequency Band	USA: 2.400-2.483 GHz, 5.15-5.35 GHz, 5.725-5.825 GHz Europe: 2.400-2.483 GHz, 5.15-5.35 GHz, 5.47-5.725 GHz Japan: 2.400-2.483 GHz, 5.150-5.250 GHz, 5.25-5.35 GHz, 5.470-5.725 GHz China: 2.400-2.483 GHz, 5.725-5.85 GHz
	Modulation technique	802.11b/g/n DSSS (DBPSK, DQPSK, CCK) OFDM (BPSK, QPSK, 16-QAM, 64-QAM) 802.11a/n OFDM (BPSK, QPSK, 16-QAM, 64-QAM)
	Effective isotropically radiated power (EIRP)	below 20 dBm
	WLAN Infrastructure	For operation with full capacity, a WLAN infrastructure is recommended that provides: <ul style="list-style-type: none"> • A minimum RF signal (RSSI) level of -67dBm (or higher) in all areas of monitor use. • A minimum signal-to-noise ratio (SNR) of 25 dB in all areas of monitor use. See the <i>IntelliVue Network Specification</i> document for details.
Near Field Communication Interface	Technology	NFCIP-1, NFCIP-2 protocol ISO/IEC 14443A, ISO/IEC 14443B FeliCa PCD mode MIFARE PCD encryption mechanism NFC Forum tag 1 to 4 ISO/IEC 15693/ICODE
	Modes	Peer-to-Peer, Reader/Writer, Card Emulation
	Band	13.56 MHz
	Modulation	ASK (active mode) or load modulation (passive mode)
	Bandwidth	106 kbit/s, 212 kbit/s, 424 kbit/s, 848 kbit/s (depending on technology used)
Measurement Link (MSL)	Connectors	MSL out (Proprietary)
	Voltage	56 V \pm 10 %
	Power	45 W
	Power Sync.	5 V CMOS Level; 78.125 kHz (typ.)
	LAN signals	10Base-T (IEEE802.3i) and 100Base-TX (IEEE802.3u) compliant
	Serial signals	RS-422 compliant
ECG Sync Output/Analog ECG Output (1/4" stereo phone jack with tip, ring, sleeve)		
General	Connector	1/4" phone with tip, ring, sleeve
	Isolation	none

38 Specifications

MX750/850		
Analog ECG Output (ring, tip)	Full scale on display	signal gain x measured ECG voltage
	Gain error	<15 %
	Baseline offset	<150 mV
	Bandwidth	1 to 100 Hz
	Output voltage swing	±4 V (min)
	Signal delay	<20 ms
	Signal delay with older versions of the M3001A MMS [identifiable with the serial number prefix DE227 or DE441 and option string #A01]	<30 ms
Digital Pulse Output (ring)	Output low voltage level	<0.4 V @ I=-1 mA
	Output high voltage level	>2.4 V @ I=1 mA
	Pulse Width	100 ms±10 ms (active high)
	Pulse Rise Time	<1 ms (from 0.4 V to 2.4 V)
	Signal delay	<25ms per AAMI EC13
	Signal delay with older versions of the M3001A MMS [identifiable with the serial number prefix DE227 or DE441 and option string #A01]	<35ms per AAMI EC13

X2 Interface Specifications

X2 (M3002A) Interface Specifications		
Measurement Link (MSL)	Connectors	MSL In (Proprietary)
	Power	30 V to 60 V input
	Power Sync.	RS-422 compliant input 78.125 kHz (typical)
	LAN signals	IEEE 802.3 10-Base-T compliant
	Serial signals	RS-422 compliant
	Local signals	Provided for connecting Measurement Extensions
ECG Sync Pulse Output (rectangular pulse)	Cable detection	Yes
	Wave Output	No
	Connector	Binder Series 709/719
	Output levels	Output low <0.8 V @ I = -4 mA
		Output high >2.4 V @ I = 4 mA
	Isolation	None
	Pulse Width	100 +/- 10 ms (high)
	Delay from R-wave peak to start of pulse	20 ms maximum per AAMI EC13
Minimum required R-wave amplitude	0.5 mV	

X2 (M3002A) Interface Specifications		
IntelliVue 802.11 Bedside Adapter (Wireless Network Adapter)	Type	Internal wireless adapter
	Technology	IEEE 802.11a/b/g
	Frequency Band	USA: 2.400 - 2.483GHz, 5.15 - 5.35GHz, 5.725 - 5.825GHz Europe: 2.400 - 2.483GHz, 5.15 - 5.35GHz, 5.47 - 5.725GHz Japan: 2.400 - 2.483GHz, 2.471 - 2.498GHz, 4.900 - 5.091GHz, 5.150 - 5.250GHz, 5.25 - 5.35GHz, 5.470 - 5.725GHz China: 2.400 - 2.483GHz, 5.725 - 5.85GHz
	Modulation Technique	802.11b/g DSSS (DBPSK, DQPSK, CCK) OFDM (BPSK, QPSK, 16-QAM, 64-QAM) 802.11a OFDM (BPSK, QPSK, 16-QAM, 64-QAM)
	Effective radiated power	max 18 dBm
Short Range Radio Interface ¹	Type	Internal SRR interface
	Technology	IEEE 802.15.4
	Frequency Band	2.4 GHz ISM (2.400-2.483 GHz)
	Modulation Technique	DSSS (O -QPSK)
	Effective radiated power	max. 0 dBm (1 mW)

¹ The short range radio interface is compatible with the following devices: TRx4841A/TRx4851A IntelliVue Telemetry System Transceiver and MX40 Wearable Patient Monitor

X3 Interface Specifications

X3 (867030) Interface Specifications		
Measurement Link (MSL)	Connectors	MSL In (Proprietary)
	Power	36 V to 60 V input
	Power Sync.	Unused
	LAN signals	IEEE 802.3 10-Base-T and 100Base-TX compliant
	Serial signals	RS-422 compliant
	Local signals	Provided for connecting measurement extensions
	Local voltage	9 V to 12.3 V - provided to power current generation measurement extensions

X3 (867030) Interface Specifications		
IntelliVue 802.11 Bedside Adapter (Wireless Network Adapter)	Type	Internal wireless adapter
	Technology	IEEE 802.11a/b/g/n
	Frequency Band	USA: 2.400-2.483 GHz, 5.15-5.35 GHz, 5.725-5.825 GHz Europe: 2.400-2.483 GHz, 5.15-5.35 GHz, 5.47-5.725 GHz Japan: 2.400-2.483 GHz, 5.15-5.25 GHz, 5.25-5.35 GHz, 5.470-5.725 GHz China: 2.400-2.483 GHz, 5.725-5.85 GHz
	Modulation Technique	802.11b/g/n DSSS (DBPSK, DQPSK, CCK) OFDM (BPSK, QPSK, 16-QAM, 64-QAM) 802.11a/n OFDM (BPSK, QPSK, 16-QAM, 64-QAM)
	Effective isotropically radiated power (EIRP)	below 20 dBm
	WLAN Infrastructure	For operation with full capacity, a WLAN infrastructure is recommended that provides: <ul style="list-style-type: none"> • A minimum RF signal (RSSI) level of -67dBm (or higher) in all areas of monitor use. • A minimum signal-to-noise ratio (SNR) of 25 dB in all areas of monitor use. See the <i>IntelliVue Network Specification</i> document for details.
IntelliVue Instrument Telemetry Wireless Network (USA only)		
Internal WMTS Adapter	Technology	compatible with Philips IntelliVue Telemetry System (TTS), cellular infrastructure
	Frequency Band	WMTS, 1395-1400 MHz and 1427-1432 MHz
	Effective isotropically radiated power (EIRP)	below 22 dBm

Integrated PC (iPC) Interface Specifications

Integrated PC (iPC) (monitor option PC1)		
Ethernet LAN (external)	Connector	RJ-45
	LAN Signals	IEE 802.3 1000-Base-T compliant
	Reinforced insulation	IEC 60601-1 compliant
USB	6 external ports (5 rear, 1 right side) Type A connectors	
	Top connector on rear and connector on right side	USB 2.0 supporting Hi-Speed mode
	Lower four connectors on rear (with blue inserts)	USB 3.0 supporting SuperSpeed mode
Audio	microphone input stereo	3.5 mm audio jack
	headphone output stereo	3.5 mm audio jack
Two independent DisplayPort outputs	DisplayPort 1.2	supports resolutions up to 2560x1600 at 60Hz

Display Specifications

Display Specifications		
22" Full HD MX850	Type	547 mm active matrix color LCD (TFT)
	Resolution	1920 x 1080 (Full HD)
	Useful Screen	476.6 mm x 268.1 mm
	Pixel Size	0.248 mm x 0.248 mm
19" Full HD MX750	Type	469 mm active matrix color LCD (TFT)
	Resolution	1920 x 1080 (Full HD)
	Useful Screen	409 mm x 230 mm
	Pixel size	0.213 mm x 0.213 mm

Compatible Devices

Displays must be approved for medical use and tested to IEC 60601-1.

Measurement Specifications

See the “[Default Settings Appendix](#)” for a list of the settings the monitor is initially shipped with.

ECG/Arrhythmia/ST/QT

Complies with:
IEC 60601-2-25:2011
ANSI/AAMI/IEC 60601-2-25:2011
IEC 60601-2-27:2011 + C1:2012
ANSI/AAMI/IEC 60601-2-27:2011 + Err:2012

ECG/Arrhythmia/ST Performance Specifications		
Cardiotach	Range	Adult/pedi: 15 to 300 bpm Neo range: 15 to 350 bpm Note: for rates less than 15 bpm, the displayed heart rate is 0.
	Accuracy	±1% of range
	Resolution	1 bpm
	Sensitivity	≥200 $\mu\text{V}_{\text{peak}}$
PVC Rate	Range	0 to 300 bpm
	Resolution	1 bpm
ST Numeric	Range	-25 to +25 mm
	Accuracy	±0.5 mm or 15%, whichever is greater
	Resolution	0.1 mm
QT Numeric	Range	200 to 800 ms
	Accuracy	±30 ms
	Resolution	8 ms
QTc Numeric	Range	200 to 800 ms
	Resolution	1 ms

38 Specifications

ECG/Arrhythmia/ST Performance Specifications		
Δ QTc Numeric	Range	-600 to +600 ms
	Resolution	1 ms
QT-HR Numeric	Range - adult	15 to 150 bpm
	Range - pediatric and neonatal	15 to 180 bpm
Sinus and SV Rhythm Ranges	Brady	Adult: 15 to 59 bpm Pedi: 15 to 79 bpm Neo: 15 to 89 bpm
	Normal	Adult: 60 to 100 bpm Pedi: 80 to 160 bpm Neo: 90 to 180 bpm
	Tachy	Adult: >100 bpm Pedi: >160 bpm Neo: >180 bpm
Bandwidth	Diagnostic Mode	Adult/neo/pedi: 0.05 to 150 Hz
	Extended Monitoring Mode	Adult/neo/pedi: 0.5 to 150 Hz
	Monitoring Mode	Adult: 0.5 to 40 Hz Neo/pedi: 0.5 to 55 Hz
	Filter Mode	Adult/neo/pedi: 0.5 to 20 Hz
Bandwidth when the ECG is transmitted from a telemetry device via short range radio	Diagnostic Mode	Adult/neo/pedi: 0.05 to 40 Hz
	Extended Monitoring Mode	Adult/neo/pedi: 0.5 to 40 Hz
	Monitoring Mode	Adult: 0.5 to 40 Hz Neo/pedi: 0.5 to 40 Hz
	Filter Mode	Adult/neo/pedi: 0.5 to 20 Hz
Differential Input Impedance		>2 MΩ RA-LL leads (Resp) >5 MΩ at all other leads (at 10 Hz including patient cable)
Common Mode Rejection Ratio		Diagnostic mode: >86 dB (with a 51 kΩ/47 nF imbalance). Filter mode: >106 dB (with a 51 kΩ/47 nF imbalance).
Electrode Offset Potential Tolerance		±500 mV
Auxiliary Current (Leads off Detection)		Active electrode: <100 nA Reference electrode: <900 nA
Input Signal Range		±5 mV
Noise		<30 μV p-p at 0.05 to 150 Hz

ECG/Arrhythmia/ST/QT Alarm Specifications	Range	Adjustment
HR	15 to 300 bpm maximum delay: 10 seconds according to AAMI EC 13-1992 standard	Adult: 1 bpm steps (15 to 40 bpm) 5 bpm steps (40 to 300 bpm) Pedi/Neo: 1 bpm steps (15 to 50 bpm) 5 bpm steps (50 to 300 bpm)
Extreme Tachy	Difference to high limit 0 to 50 bpm	5 bpm steps
	Clamping at 150 to 300 bpm	5 bpm steps
Extreme Brady	Difference to low limit 0 to 50 bpm	5 bpm steps
	Clamping at 15 to 100 bpm	5 bpm steps
Run PVCs	None, fixed setting 2 PVCs	Not adjustable by user

ECG/Arrhythmia/ST/QT Alarm Specifications	Range	Adjustment
PVCs Rate	1 to 99 PVCs/minute	1 PVC
Vent Tach HR	20 to 300 bpm	5 bpm
Vent Tach Run	3 to 99 PVCs/minute	1 PVC
Vent Rhythm Run	3 to 99 PVCs/minute	1 PVC
SVT HR	120 to 300 bpm	5 bpm
SVT Run	3 to 99 SV beats	1 SV beat
ST High	-19.8 to +20 mm	0.2 mm
ST Low	-20 to +19.8 mm	0.2 mm
STE Limit	-20 to +20 mm	0.2 mm
QTc High	200 ms to 800 ms	10 ms steps
Δ QTc High	30 ms to 200 ms	10 ms steps

ECG/Arrhythmia/ST Supplemental Information as required by AAMI EC11/13, IEC 60601-2-27		
Respiration Excitation Waveform		Sinusoidal signal, 260 μ A, 40.5 kHz
Noise Suppression		RL drive gain 44 dB max., max. voltage 1.8 Vrms
Time to Alarm for Tachycardia	Vent Tachycardia 1 mV _{pp} , 206 bpm	Gain 0.5, Range 6.5 to 8.4 seconds, Average 7.2 seconds
		Gain 1.0 Range 6.1 to 6.9 seconds, Average 6.5 seconds
		Gain 2.0, Range 5.9 to 6.7 seconds, Average 6.3 seconds
	Vent Tachycardia 2 mV _{pp} , 195 bpm	Gain 0.5, Range 5.4 to 6.2 seconds, Average 5.8 seconds
		Gain 1.0, Range 5.7 to 6.5 seconds, Average 6.1 seconds
		Gain 2.0, Range 5.3 to 6.1 seconds, Average 5.7 seconds
Tall T-Wave Rejection Capability		Maximum rejected T-wave amplitude is 1.8 mV (According to IEC 60601-2-27, 201.12.1.101.17)
Heart Rate Averaging Method		Three different methods are used: Normally, heart rate is computed by averaging the 12 most recent R-R intervals. For runs of PVCs, up to 8 R-R intervals are averaged to compute the HR. If each of 3 consecutive R-R intervals is greater than 1200 ms (that is, rate less than 50 bpm), then the 4 most recent R-R intervals are averaged to compute the HR.
Response Time of Heart Rate Meter to Change in Heart Rate		HR change from 80 to 120 bpm: Range: [6.4 to 7.2 seconds] Average: 6.8 seconds HR change from 80 to 40 bpm: Range: [5.6 to 6.4 sec] Average: 6.0 seconds
Heart Rate Meter Accuracy and Response to Irregular Rhythm		Ventricular bigeminy: 80 bpm Slow alternating ventricular bigeminy: 60 bpm Rapid alternating ventricular bigeminy: 120 bpm Bidirectional systoles: 90 bpm
Accuracy of Input Signal Reproduction		Methods A and D were used to establish overall system error and frequency response.
Pacemaker Pulse Rejection Performance		Rejection of pacemaker pulses with amplitudes from ± 2 mV to ± 700 mV and widths from 0.1 ms to 2.0 ms (Method B)
Pacemaker Pulse Rejection of fast ECG signals		2.2 V/s RTI (Paced Mode)
Minimum input slew rate		2.2 V/s RTI

Respiration

Respiration Performance Specifications		
Respiration Rate	Range	Adult/pedi: 0 to 120 rpm Neo: 0 to 170 rpm
	Accuracy	at 0 to 120 rpm ± 1 rpm at 120 to 170 rpm ± 2 rpm
	Resolution	1 rpm
Bandwidth		0.3 to 2.5 Hz (-6 dB)
Noise		Less than 25 m Ω (rms) referred to the input

Respiration Alarm Specifications	Range	Adjustment	Delay
High	Adult/pedi: 10 to 100 rpm Neo: 30 to 150 rpm	< 20 rpm: 1 rpm steps \geq 20 rpm: 5 rpm steps	max. 14 seconds
Low	Adult/pedi: 0 to 95 rpm Neo: 0 to 145 rpm	< 20 rpm: 1 rpm steps \geq 20 rpm: 5 rpm steps	for limits from 0 to 20 rpm: max. 4 seconds for limits above 20 rpm: max. 14 seconds
Apnea Alarm	10 to 40 seconds	5 second steps	

SpO₂

Complies with: ISO 80601-2-61:2011

Unless otherwise specified, this information is valid for SpO₂ measured using the M3001A, M3002A, 867036, and 867030 Multi-Measurement modules and the M1020B measurement module.

Measurement Validation: The SpO₂ accuracy has been validated in human studies against arterial blood sample reference measured with a CO-oximeter. Pulse oximeter measurements are statistically distributed, only about two-thirds of the measurements can be expected to fall within the specified accuracy compared to CO-oximeter measurements.

Display Update Period: Typical: 2 seconds, Maximum: 30 seconds. Maximum with NBP INOP suppression on: 60 seconds.

Philips FAST SpO₂ Performance Specifications

SpO ₂ Performance Specifications		
SpO₂ The specified accuracy is the root-mean-square (RMS) difference between the measured values and the reference values	Range	0 to 100%
	Option #A01/#SP1 Accuracy	Philips Reusable Sensors: M1191A, M1191AL, M1191B, M1191BL, M1192A = 2 % (70 % to 100 %) M1193A, M1194A, M1195A, M1196A, M1196S = 3 % (70 % to 100 %) M1191T, M1192T, M1193T (Adult), M1196T = 3% (70% to 100%) M1193T (Neonate) = 4 % (70% to 100%) Philips Disposable Sensors with M1943A(L): M1132A, M1133A (adult/infant), M1134A (adult/infant) = 2 % M1901B, M1902B, M1903B, M1904B, M1131A, M1133A (neonate), M1134A (neonate) = 3 % (70% to 100%) Nellcor Sensors with M1943A(L): MAXA, MAXAL, MAXP, MAXI, MAXN, D-25, D-20, I-20, N-25, Oxicliq A, P, I, N = 3 % (70% to 100%) Masimo Reusable Sensors with LNC MP10: LNCS DCI, LNCS DCIP, LNCS YI (adult/pedi/infant) = 2% (70% to 100%) LNCS YI (neonate) = 3% (70% to 100%) LNCS TC-I: 3.5 % (70% to 100%) Masimo Disposable Sensors with LNC MP10: LNCS Actx, LNCS Actx-3, LNCS Pctx, LNCS Pctx-3, LNCS Inf, LNCS Inf-3, LNCS Neo (adult), LNCS Neo-3 (adult) = 2% (70% to 100%) LNCS Neo (neonate), LNCS Neo-3 (neonate), LNCS NeoPt, LNCS NeoPt-3 = 3% (70% to 100%)
	Option #A02 Accuracy	Philips Reusable Sensors: M1193AN = 3 % (70% to 100%) Philips Disposable Sensors with M1943NL: M1901B (Adult), M1902B, M1903B, M1904B = 2% (70% to 100%) M1901B (Neonate) = 3% Nellcor Sensors with M1943NL: MAXFAST, MAXA, MAXAL, MAXP, MAXI, MAXN (Adult) = 2 % (70 % to 100 %) SC-A, Oxicliq A, P, I, N (Adult) = 2.5% (70% to 100%) MAXN (Neonate), Dura-Y D-YS (Infant to Adult), DS-100A-1, Oxiband OXI-A/N (Adult), OXI-P/I = 3 % (70% to 100%) MAXR, Oxicliq N (Neonate), SCNEO-I (Neonate), SC-PR-I (Neonate), Dura-Y D-YS with D-YSE or D-YSPD clip = 3.5 % (70% to 100%) Dura-Y D-YS (Neonate), Oxiband OXI-A/N (Neonate) = 4% (70% to 100%)
	Resolution	1%
	Averaging Time	5, 10 or 20 seconds (user adjustable)
Pulse	Range	30 to 300 bpm
	Accuracy	±2% or 1 bpm, whichever is greater
	Resolution	1 bpm
Numeric Update Rate		Typical: 2 seconds, Maximum: 30 seconds. Maximum with NBP INOP suppression on: 60 seconds

SpO ₂ Performance Specifications		
Sensors		Wavelength range: 500 to 1000 nm Emitted Light Energy: ≤15 mW Information about the wavelength range can be especially useful to clinicians (for instance, when photodynamic therapy is performed)
Pulse Oximeter Calibration Range		70% to 100%

Nellcor OxiMax Performance Specifications

Pulse Oximetry Performance Specifications		
SpO ₂ The specified accuracy is the root-mean-square (RMS) difference between the measured values and the reference values	Range	1 to 100%
	Accuracy	M1901B ¹ , M1902B, M1903B, M1904B, MAXA, MAXAL, MAXP, MAXI, MAXN ¹ , MAXFAST: adult/infant = 2% (70% to 100%) M1902B, M1903B, M1904B, MAXA, MAXAL, MAXP, MAXI, MAXN ¹ , MAXFAST: adult = 3% (60% to 80%) MAXN ¹ : neonate = 2% (70% to 100%) Oxicliq A, Oxicliq P, Oxicliq I, Oxicliq N ⁴ : adult/infant = 2.5% (70% to 100%) Oxicliq N ⁴ : neonate = 3.5% (70% to 100%) MAXR ² : adult/infant = 3.5% (70% to 100%) SoftCare SC-A (adult/infant), SoftCare SC-PR-I ³ (neonate), SoftCare SCNEO-I ³ : (neonate) = 2% (70% to 100%) DS-100A-1, D-YS, Oxiband OXI-A/N, Oxiband OXI-P/I: adult/infant = 3% (70% to 100%) D-YS ⁴ , Oxiband OXI-A/N ⁴ : neonate = 4% (70% to 100%)
	Low perfusion accuracy ⁵	2% (70 - 100%)
	Resolution	1%
Pulse	Range	25 to 300 bpm
	Accuracy	+/- 3 bpm (25 to 250 bpm)
	Low perfusion accuracy ⁵	+/- 3 bpm (25 to 250 bpm)
	Resolution	1 bpm
Numeric update rate		typical 1 second, max ≤60 seconds
Sensors		Wavelength range: 500 to 1000 nm Emitted Light Energy: ≤15 mW Information about the wavelength range can be especially useful to clinicians (for instance, when photodynamic therapy is performed)

1. M1901B/MAXN:

Clinical functionality has been demonstrated on a population of hospitalized neonate patients. The observed SpO₂ accuracy was 2.5% in a study of 42 patients with ages of 1 to 23 days, weight from 750 to 4100 grams, and 63 observations made spanning a range of 85 to 99% SaO₂ while monitored with Nellcor OxiMax N-595 pulse oximeters.

2. The accuracy specification has been determined between saturations of 80%–100%.

3. SoftCare SC-PR-I, SCNEO-I:

Clinical functionality has been demonstrated on a population of hospitalized neonate and infant patients. The observed SpO₂ accuracy was 3.0% in a study of 57 patients with ages of 24 to 40 weeks, weight from 710 to 5,000 grams, and 185 observations made spanning a range of 63 to 100% SaO₂ while monitored with Nellcor OxiMax N-595 pulse oximeters.

4. Neonatal accuracy: When sensors are used on neonatal subjects as recommended, the specified accuracy range is increased by ± 1 digit, as compared to adult usage, to account for the theoretical effect on oximeter measurements of fetal hemoglobin in neonatal blood. For example, Oxiciq N accuracy on neonates is ± 3.5 digits, rather than ± 2.5 .

5. Specification applies to the performance of the device. Reading accuracy in the presence of low perfusion (detected IR pulse modulation amplitude 0.03% - 1.5%) was validated using signals supplied by a patient simulator. SpO₂ and pulse rate values were varied across the monitoring range over a range of weak signal conditions and compared to the known true saturation and pulse rate of the input signals.

Masimo SET Performance Specifications

Pulse Oximetry Performance Specifications		
SpO ₂	Range	1 to 100%
	Accuracy ¹	No Motion Accuracy ^{2, 3} Masimo LNCS: Adtx, Adtx-3, Pdtx, Pdtx-3, Inf, Inf-3, Neo (Adult), Neo-3 (Adult), DCI, DCIP, TF-I, YI (Adult/Pedi/Infant), Trauma, Newborn Infant/Pediatric ⁴ = 2% (70% to 100%) Neo (Neo), Neo-3 (Neo), NeoPt, NeoPt-3 YI (Neo), Newborn Neonatal ⁵ = 3% (70% to 100%) TC-I = 3.5% (70% to 100%)
		Motion Accuracy ^{3, 6} Masimo LNCS: Adtx, Adtx-3, Pdtx, Pdtx-3, Inf, Inf-3, Neo, Neo-3, NeoPt, NeoPt-3, Trauma ⁴ , Newborn Neonatal ⁴ , Newborn Infant/Pediatric ⁴ , DCI, DCIP, YI = 3% (70% to 100%)
		Low Perfusion Accuracy ^{7, 3} : Masimo LNCS: Adtx, Adtx-3, Pdtx, Pdtx-3, Inf, Inf-3, Neo (Adult), Neo-3 (Adult), Trauma, Newborn Infant/Pediatric, DCI, DCIP, TF-I = 2% (70% to 100%) Neo (Neo), Neo-3 (Neo), NeoPt, NeoPt-3, Newborn Neonatal = 3% (70% to 100%) TC-I = 3.5% (70% to 100%)
Resolution	1%	
Pulse	Range	25 to 240 bpm
	Accuracy ¹	No motion accuracy ^{2,8,9} : 3 bpm Motion accuracy ^{6,9,10} : 5 bpm Low perfusion accuracy ^{7,11} : 3 bpm
	Resolution	1 bpm
Numeric update rate		typical 1 second, maximum for all numerics from this measurement: 30 seconds
Sensors		Wavelength range: 500 to 1000 nm Emitted Light Energy: ≤ 15 mW Information about the wavelength range can be especially useful to clinicians (for instance, when photodynamic therapy is performed)

1. The specified accuracy is the root-mean-square (RMS) difference between the measured values and the reference values.

2. Masimo SET technology with LNCS sensors have been validated for no motion accuracy in human blood studies on healthy adult volunteers in induced hypoxia studies in the range of 70 to 100% SpO₂ against a laboratory CO-oximeter and ECG monitor. This variation equals plus or minus one standard deviation, which encompasses 68% of the population.

3. 1% has been added to the saturation accuracy for neonates to account for the effects of fetal hemoglobin.

4. Accuracy determined by testing on adults.

38 Specifications

5. Accuracy determined by testing on adults, with ARMS accuracy over 70%-100% saturation of 2%.
6. Masimo SET technology with LNCS sensors have been validated for motion accuracy in human blood studies on healthy adult volunteers in induced hypoxia studies while performing rubbing and tapping motions, at 2 to 4 Hz at an amplitude of 1 to 2 cm and a non-repetitive motion between 1 to 5 Hz at an amplitude of 2 to 3 cm in induced hypoxia studies in the range of 70-100% SpO₂ against a laboratory CO-oximeter and ECG monitor. This variation equals plus or minus one standard deviation, which encompasses 68% of the population.
7. Masimo SET technology has been validated for low perfusion accuracy in bench top testing against a Biotek Index 2 simulator and Masimo's simulator with signal strengths of greater than 0.02% and a % transmission of greater than 5% for saturations ranging from 70 to 100%. This variation equals plus or minus one standard deviation, which encompasses 68% of the population.
8. Masimo SET technology with LNCS sensors have been validated for pulse rate accuracy for the range of 25 - 240 bpm in bench top testing against a Biotek Index 2 simulator. this variation equals plus or minus one standard deviation, which encompasses 68% of the population.
9. Pulse Rate accuracy determined by testing on adults for LNCS Trauma, Newborn Neonatal, Newborn Infant/ Pediatric sensors.
10. Motion performance does not apply to LNCS TF-I, TC-I sensors.
11. Low perfusion performance does not apply to LNCS YI.

SpO₂ Alarm Specifications

SpO ₂ Alarm Specifications	Range	Adjustment
SpO ₂ high and low limit alarms	Adult: 50 to 100% Pedi/Neo: 30 to 100%	1% steps
Desat	Adult: 50% to Low alarm limit Pedi/Neo: 30% to Low alarm limit	1% steps
Pulse	30 to 300 bpm	Adult: 1 bpm steps (30 to 40 bpm) 5 bpm steps (40 to 300 bpm) Pedi/Neo: 1 bpm steps (30 to 50 bpm) 5 bpm steps (50 to 300 bpm)
Tachycardia	Difference to high limit 0 to 50 bpm	5 bpm steps
	Clamping at 150 to 300 bpm	5 bpm steps
Bradycardia	Difference to low limit 0 to 50 bpm	5 bpm steps
	Clamping at 30 to 100 bpm	5 bpm steps

SpO ₂ Alarm Specifications (cont.)	Standard Delay	Smart Alarm Delay (alternative to standard alarm delay)		
		Short Mode	Medium mode	Long Mode
SpO ₂ high and low limit alarms	0 to 30 seconds (adjustable in 1 second steps) + system alarm delay ¹	10 to 25 seconds + system alarm delay	10 to 50 seconds + system alarm delay	10 to 100 seconds + system alarm delay
Desat	0 to 30 seconds (adjustable in 1 second steps) + system alarm delay	not supported		
Pulse	10 seconds + system alarm delay			
Tachycardia	10 seconds + system alarm delay			
Bradycardia	10 seconds + system alarm delay			

1. Refer to "Monitor Performance Specifications" on page 481 for system alarm delay specification.

SpO ₂ Smart Alarm Delay - Detailed Specifications			
Deviation from violated alarm limit	Resulting alarm delay according to selected mode		
	Short	Medium	Long
1%	25 sec (maximum delay)	50 sec (maximum delay)	100 sec (maximum delay)
2%	12 sec	25 sec	50 sec
3%	10 sec	16 sec	33 sec
4%	10 sec	12 sec	25 sec
5%	10 sec	10 sec	20 sec
6%	10 sec	10 sec	16 sec
7%	10 sec	10 sec	14 sec
8%	10 sec	10 sec	12 sec
9%	10 sec	10 sec	11 sec
>9%	10 sec	10 sec	10 sec

Masimo rainbow SET

Performance Specifications

The SpO₂ performance specifications in this section apply to devices with the Masimo rainbow SET technology. Unless otherwise noted the calibration range for the SpO₂ accuracy specification is from 70-100%.

Complies with ISO 80601-2-61:2011 / EN ISO 80601-2-61:2011.

General Performance Specification SpO ₂	
Numeric update rate for SpO ₂ , Pulse Rate, and Perf	Typical: 1 second Maximum: 30 seconds
Sensors	Emitted Light Energy ≤ 25mW Wavelength Range 500-1400nm Information about wavelength range can be especially useful to clinicians (for instance when photodynamic therapy is performed).

Operating Conditions

Besides the specification in the monitor Instructions for Use, the following additional environmental limitations apply for the Masimo rainbow SET measurement:

Environmental Limitations	
Incandescent Light Intensity	≤ 100 Klux
Fluorescent Light Intensity	≤ 10 Klux

Environmental Limitations	
Fluorescent Light Frequency	50, 60 Hz \pm 1.0 Hz (LNOP, LNCS Sensors) 50, 60 Hz \pm 0.5 Hz (rainbow Sensors)
Ambient Noise Level (Sound Pressure Level) (applies to acoustic respiration measurement only)	\leq 65 dB Alarm tolerant

Electromagnetic Emissions

The device is suitable for use in the electromagnetic environment specified in the table below. You must ensure that it is used in such an environment.

Emissions test	Compliance	Avoiding Electromagnetic Interference
Radiofrequency (RF) emissions	Group 1	The monitor uses RF energy only for its internal function. Therefore, its RF emissions are very low and are not likely to cause any interference in nearby electronic equipment
RF emissions CISPR 11	Class A	The monitor is suitable for use in all establishments other than those directly connected to the public low-voltage power supply network that supplies buildings used for domestic purposes.

Measurement Accuracy

The following accuracy specifications represent only the device's portion of the integrated Masimo rainbow SET technology performance. The actual measurement performance and accuracy depends on the accessory used, and can be limited by the accessory as specified in the sensor's DFU.

Ensure you only use accessories that are specified and provide accuracy specifications applicable for your device.

Measurement	Accuracy
SpO ₂ , no motion	60-80 \pm 3%, Adults/Pediatrics/Infants 70-100 \pm 2%, Adults/Pediatrics/Infants, \pm 3% Neonates
SpO ₂ , motion	70-100 \pm 3%, Adults/Pediatrics/Infants/Neonates
SpO ₂ , Low Perfusion	70-100 \pm 2%, Adults/Pediatrics/Infants/Neonates
Pulse Rate, no motion	25-240 \pm 3 bpm Adults/Pediatrics/Infants/Neonates
Pulse Rate, motion	25-240 \pm 5 bpm Adults/Pediatrics/Infants/Neonates
Pulse Rate, Low Perfusion	25-240 \pm 3 bpm Adults/Pediatrics/Infants/Neonates
SpCO	1-40 \pm 3% Adults/Pediatrics/Infants
SpMet	1-15 \pm 1% Adults/Pediatrics/Infants/Neonates
SpHb	8-17 \pm 1 g/dl (arterial or venous) Adults/Pediatrics
RRac	4-70 \pm 1 breath per minute, Adults/Pediatrics (>10 kg)



Measurement Validation

The Masimo rainbow SET technology with the designated sensors has been validated by Masimo during motion and no motion conditions in human studies against an arterial blood sample reference measured with a CO-oximeter and an ECG monitor. Pulse oximeter measurements are statistically distributed, only about two-thirds of the measurements can be expected to fall within the specified accuracy compared to CO-oximeter measurements. For more details refer to the sensor's DFU.

NOTE

A functional tester cannot be used to assess the accuracy of the Masimo rainbow SET measurement or accessories.

Measurement Range and Resolution

Measurement	Measurement Range	Resolution
Arterial Oxygen Saturation (SpO ₂)	0-100%	1%
Signal Quality Indicator (SQI)	The signal quality indicator represents the functional SpO ₂ Confidence as it is reported by the Masimo rainbow SET measurement board. >90% is represented as filled:  >30% and ≤90% is represented as half-filled:  ≤30% is represented as empty: 	1%
Perfusion Index (Perf)	0.02-20.00 for disposable sensors 0.05-20.00 for reusable sensors	0.01
Pleth Variability Index (PVI)	0-100%	1%
Pulse Rate from Plethysmogram (Pulse)	25-240 bpm	1 bpm
Carboxyhemoglobin Saturation (SpCO)	0-100%	1%
Methemoglobin Saturation (SpMet)	0-100%	0.1%
Total Hemoglobin Saturation (SpHb)	0.0-25.0 g/dl (0.0-15.5 mmol/l)	0.1 g/dl (0.1 mmol/l)
Total Oxygen Concentration (SpOC)	0.0-35 ml/dl	1 ml/dl
Acoustic Respiration Rate (RRac)	4-70 rpm	1 rpm

Alarm Specifications**Alarm Limits****SpO₂**

Patient Category	High Range	Low Range	Desat Range	Adjustment Steps
Adult	51-100%	50-99%	50-99%	1%
Neonate/Pediatric	31-100%	30-99%	30-99%	1%

SpMet

Patient Category	High Range	Low Range	Adjustment Steps
Adult/Pediatric/Neonate	0.1-100%	0.0-99%	0.1% (0.0-9.9%) 1% (10-100%)

SpCO

Patient Category	High Range	Low Range	Adjustment Steps
Adult/Pediatric/Neonate	1-100%	0-99%	1%

SpHb

Patient Category	High Range	Low Range	Adjustment Steps
Adult/Pediatric/Neonate	0.1-25.0 g/dl 0.1-15.5 mmol/l	0.0-24.5 g/dl 0.0-15.0 mmol/l	0.1g/dl (0.0-9.9 g/dl) 0.1mmol/l (0.0-9.9 mmol/l) 0.5 g/dl (10.0-25.0 g/dl) 0.5 mmol/l (10.0-15.5 mmol/l)

SpOC

Patient Category	High Range	Low Range	Adjustment Steps
Adult/Pediatric/Neonate	1-35 ml/dl	0-34 ml/dl	1 ml/dl

Pulse

NOTE

The Masimo rainbow SET technology only provides pulse rate values up to 240 bpm. To get pulse rate alarms, set the high alarm limit below 240 bpm.

Patient Category	High Range	Low Range	Adjustment Steps
Adult	31-300 bpm	30-295 bpm	1 bpm (30-40 bpm) 5 bpm (40-300 bpm)
Neonate/Pediatric	31-300 bpm	30-295 bpm	1 bpm (30-50 bpm) 5 bpm (50-300 bpm)

	Range	Clamping at	Adjustment Steps
Tachycardia	Delta to the high limit 0-50 bpm	150-300 bpm	5 bpm
Bradycardia	Delta to the low limit 0-50 bpm	30-100 bpm	5 bpm

PVI

Patient Category	High Range	Low Range	Adjustment Steps
Adult/Pediatric/Neonate	1-100%	0-99%	1%

RRac

The Masimo rainbow SET technology only provides respiration rate values from 4 rpm to 70 rpm. For respiration rate alarms, set the high alarm limit below 70 rpm and the low alarm limit above 4 rpm.

Patient Category	High Range	Low Range	Adjustment Steps
Adult/Pediatric	10-100 rpm	0-95 rpm	1 rpm steps below 20 rpm 5 rpm steps above 20 rpm
Neonate	30-150 rpm	0-145 rpm	1 rpm steps below 20 rpm 5 rpm steps above 20 rpm

RRac Pause Time

Range	Adjustment Steps
15-40 seconds	5 seconds

Perf

Patient Category	High Range	Low Range	Adjustment Steps
Adult/Pediatric/Neonate	0.10-20.00	0.02-19.00	0.01 (0.02-0.10) 0.10 (0.10-1.00) 1.00 (1.00-20.00)

3D Perf Delta

% Decrease	Adjustment Steps	Duration	Adjustment Steps
10-100%	2%	1 min - 48 hr, Infinite	1 min, 5 min, 30 min, 1 hr, 4 hr, 8 hr, 12 hr, 24 hr, 36 hr, 48 hr, Infinite

3D Desat Index

3D Desat Index Settings	Range	Adjustment Steps
Delta Threshold	2-10%	1 %
Count	1-25	1
Period	1-4 hrs	1 hrs

Alarm Delays

Alarm	Standard Delay	Smart Alarm Delay		
		Short Mode	Medium Mode	Long Mode
SpO ₂ high and low limit alarms	0-30 seconds (adjustable in 1 second steps) + system alarm delay	10-25 seconds + system alarm delay	10-50 seconds + system alarm delay	10-100 seconds + system alarm delay

Alarm	Standard Delay
Desat	0-30 seconds (adjustable in 1 second steps) + system alarm delay
Pulse	10 seconds + system alarm delay
Tachycardia	10 seconds + system alarm delay

38 Specifications

Alarm	Standard Delay
Bradycardia	10 seconds + system alarm delay
RRac	0, 10, 15, 30, 60 seconds + system alarm delay
PVI	system alarm delay
Perf	system alarm delay
SpCO	system alarm delay
SpHb	system alarm delay
SpMet	system alarm delay
SpOC	system alarm delay

NBP

Complies with: IEC 80601-2-30:2010 + A1:2013/EN 80601-2-30:2010

NBP Performance Specifications		
Measurement Ranges	Systolic	Adult: 30 to 270 mmHg (4 to 36 kPa) Pedi: 30 to 180 mmHg (4 to 24 kPa) Neo: 30 to 130 mmHg (4 to 17 kPa)
	Diastolic	Adult: 10 to 245 mmHg (1.5 to 32 kPa) Pedi: 10 to 150 mmHg (1.5 to 20 kPa) Neo: 10 to 100 mmHg (1.5 to 13 kPa)
	Mean	Adult: 20 to 255 mmHg (2.5 to 34 kPa) Pedi: 20 to 160 mmHg (2.5 to 21 kPa) Neo: 20 to 120 mmHg (2.5 to 16 kPa)
	Pulse Rate	Adult: 40 to 300 bpm Pedi: 40 to 300 bpm Neo: 40 to 300 bpm
Accuracy	Max. Std. Deviation: 8 mmHg (1.1 kPa) Max. Mean Error: ± 5 mmHg (± 0.7 kPa)	
Pulse Rate Measurement Accuracy	40 to 100 bpm: ± 5 bpm 101 to 200 bpm: $\pm 5\%$ of reading 201 to 300 bpm: $\pm 10\%$ of reading (average over NBP measurement cycle)	
Pulse Rate Range	40 to 300 bpm	
Measurement Time	Typical at HR >60 bpm Auto/manual/sequence: Adult: 30 seconds Neonatal: 25 seconds Stat: 20 seconds Maximum time: Adult/pedi: 180 seconds Neo: 90 seconds	
Cuff Inflation Time	Typical for normal adult cuff: Less than 10 seconds Typical for neonatal cuff: Less than 2 seconds	
Initial Cuff Inflation Pressure	Adult: 165 ± 15 mmHg Pedi: 130 ± 15 mmHg Neo: 100 ± 15 mmHg	
Maximum Cuff Pressure	Adult/Pedi: 300 mmHg Neo: 150 mmHg	

NBP Performance Specifications		
Auto Mode Repetition Times	1 min, 2 min, 2.5 min, 3 min, 5 min, 10 min, 15 min, 20 min, 30 min, 45 min, 1 h, 2 h, 4 h, 8 h, 12 h, 24 h	
STAT Mode Cycle Time	5 minutes	
Venipuncture Mode Inflation		
Inflation Pressure	Adult	20 to 120 mmHg (3 to 16 kPa)
	Pediatric	20 to 80 mmHg (3 to 11 kPa)
	Neonatal	20 to 50 mmHg (3 to 7 kPa)
Automatic deflation after	Adult/pediatric	170 seconds
	Neonatal	85 seconds

Measurement Validation: Clinical investigation according to ISO 81060-2:2013 with the auscultatory reference method:

- the 5th Korotkoff sound (K5) was used in adult / adolescent subjects and the 4th Korotkoff sound (K4) was used in pediatric subjects to determine the diastolic reference pressures.
- the approximation $MAP = (2 \cdot DIA + SYS) / 3$ was used to calculate reference MAP (mean arterial pressure) values from the systolic and diastolic reference pressures.

Clinical investigation according to ISO 81060-2:2013 with the intra-arterial reference method:

- the radial artery was used for the intra-arterial reference measurement.
- the MAP values displayed by the reference invasive blood pressure monitor were used as MAP reference values.
- blood pressure recordings with any arrhythmias were excluded.

NBP Alarm Specifications	Range	Adjustment
Systolic	Adult: 30 to 270 mmHg (4 to 36 kPa)	10 to 30 mmHg: 2 mmHg (0.5 kPa) >30 mmHg: 5 mmHg (1 kPa)
	Pedi: 30 to 180 mmHg (4 to 24 kPa)	
	Neo: 30 to 130 mmHg (4 to 17 kPa)	
Diastolic	Adult: 10 to 245 mmHg (1.5 to 32 kPa)	
	Pedi: 10 to 150 mmHg (1.5 to 20 kPa)	
	Neo: 10 to 100 mmHg (1.5 to 13 kPa)	
Mean	Adult: 20 to 255 mmHg (2.5 to 34 kPa)	
	Pedi: 20 to 160 mmHg (2.5 to 21 kPa)	
	Neo: 20 to 120 mmHg (2.5 to 16 kPa)	

NBP Overpressure Settings		
Adult	>300 mmHg (40 kPa) >2 sec	not user adjustable
Pediatric	>300 mmHg (40 kPa) >2 sec	
Neonate	>150 mmHg (20 kPa) >2 sec	

Invasive Pressure and Pulse

Complies with: IEC 60601-2-34:2011/EN 60601-2-34:2014

Invasive Pressure Performance Specifications		
Measurement Range		-40 to 360 mmHg (-5 to 48 kPa)
Pulse Rate	Range	25 to 350 bpm
	Accuracy	±1% Full Range
	Resolution	1 bpm
Input Sensitivity		Sensitivity: 5 $\mu\text{V}/\text{V}/\text{mmHg}$ (37.5 $\mu\text{V}/\text{V}/\text{kPa}$) Adjustment range: ±10%
Transducer		Load Impedance: 200 to 2000 Ω (resistive) Output Impedance: $\leq 3000 \Omega$ (resistive)
Frequency Response		dc to 12 Hz or 40 Hz
Zero Adjustment	Range	±200 mmHg (±26 kPa)
	Accuracy	±1 mmHg (±0.1 kPa)
	Drift	Less than 0.1 mmHg/°C (0.013 kPa/°C)
Gain Accuracy	Accuracy	±1%
	Drift	Less than 0.05%/°C
	Non linearity and Hysteresis	Error of $\leq 0.4\%$ FS (@CAL 200 mmHg)
Overall Accuracy	(including transducer)	±4% of reading or ±4 mmHg (±0.5 kPa), whichever is greater
Volume displacement of CPJ840J6		0.1 mm ³ / 100 mmHg

Analog output Specifications		
Analog Output available only with M1006B #C01 (@ CAL 200 mmHg)	Range	-0.4 V to 3.6 V
	Level	1 V / 100 mmHg
	Accuracy	±3% full scale
	Offset	±30 mV
	Resolution	8 Bit (@ 5 V range)
	Signal delay	20 ms

Invasive Pressure Alarm Specifications

Invasive Pressure Alarm Specifications	Range	Adjustment	Delay
Pressure	-40 to 360 mmHg (-5.0 to 48.0 kPa)	-40 to 50 mmHg (-5.0 to 7.0 kPa) 2 mmHg (0.5 kPa) >50 mmHg (>7.0 kPa) 5 mmHg (1.0 kPa)	max. 12 seconds
Extreme High	Difference to high limit 0 to 25 mmHg (0 to 3.5 kPa)	5 mmHg steps (0.5 kPa)	
	Clamping at -35 to 360 mmHg (-4.0 to 48.0 kPa)	5 mmHg steps (1.0 kPa)	
Extreme Low	Difference to low limit 0 to 25 mmHg (0 to 3.5 kPa)	5 mmHg steps (0.5 kPa)	
	Clamping at -40 to 355 mmHg (-5.0 to 47.0 kPa)	5 mmHg steps (1.0 kPa)	
Pulse	25 to 300 bpm	Adult: 1 bpm steps (25 to 40 bpm) 5 bpm steps (40 to 300 bpm) Pedi/Neo: 1 bpm steps (25 to 50 bpm) 5 bpm steps (50 to 300 bpm)	max. 14 seconds
Tachycardia	Difference to high limit 0 to 50 bpm	5 bpm steps	max. 14 seconds
	Clamping at 150 to 300 bpm	5 bpm steps	
Bradycardia	Difference to low limit 0 to 50 bpm	5 bpm steps	max. 14 seconds
	Clamping at 25 to 100 bpm	5 bpm steps	

Cerebral Perfusion Specifications

CPP Specifications		
CPP	Range	-40 to 360 mmHg (-5 to 48 kPa)

CPP Alarm Specifications	Range	Adjustment
CPP	-30 to 270 mmHg (-4 to 36 kPa)	2 mmHg steps (30 to 50 mmHg) 5 mmHg steps (50 to 270 mmHg) [0.5 kPa steps (-4.0 to 7.0 kPa) 1.0 kPa steps (7.0 to 36.0 kPa)]

Pulse Pressure Variation Specifications

PPV Specifications		
PPV	Measurement range	0 to 200%
	Physiological range	0 to 25%

Temp

Complies with: ISO 80601-2-56:2017/EN ISO 80601-2-56:2017

Specified without transducer.

Temp Performance Specifications		
Temp	Range	-1 to 45°C (30 to 113°F)
	Resolution	0.1°C (0.1°F)
	Accuracy	±0.1°C (±0.2°F)
Average Time Constant		Less than 10 seconds

Temp Alarm Specifications	Range	Adjustment
Temp High/Low Alarms	-1 to 45°C (30 to 113°F)	-1 to 30°C (30 to 86°F), 0.5°C (1.0°F) steps 30 to 45°C (86 to 113°F), 0.1°C (0.2°F) steps

Temperature Difference Specifications

Temp Difference Specifications		
ΔTemp	Range	-46 to 46°C (-83 to 83°F)
	Resolution	0.1°C (0.1°F)

Tympanic Temperature

Complies with:

- EN 12470-5 (Clinical thermometers - Part 5:2003: Performance of infrared thermometers)
- ASTM E1965-98 (Infrared Thermometers for Intermittent Determination of Patient Temperature)

with minor exceptions as noted below.

Performance Specifications		
Temperature Resolution	0.1°C or 0.1°F	
Response Time	<2 seconds	
Temperature Calibrated Accuracy Specifications (out of the Factory)		
Ambient Temperature	Target Temperature	Accuracy
25°C (77°F)	37.7°C to 38.9°C (98.4°F to 102°F)	±0.1°C (±0.2°F)
16°C to 33°C (60.8° to 91.4°F)	33°C to 42°C (91.4°F to 107.6°F)	±0.2°C (±0.4°F)
Temperature Calibrated Accuracy Specifications (after recalibration using Genius 2 Checker/Calibrator)		
Ambient Temperature	Target Temperature	Accuracy
16°C to 33°C (60.8° to 91.4°F)	36°C to 39°C (96.8°F to 102.2°F)	±0.2°C (±0.4°F)

Performance Specifications		
16°C to 33°C (60.8° to 91.4°F)	<36°C or >39°C (<96.8°F or >102.2°F)	±0.3°C (±0.5°F)
<p>ASTM laboratory requirement for IR thermometers in the display range 37°C to 39°C (98°F to 102°F) is ±0.2°C (±0.4°F), whereas for mercury-in-glass and electronic thermometers, the requirement per ASTM standards E667-86 and E1112-86 is ±0.1°C (±0.2°F).</p> <p>Clinical accuracy characteristics and procedures are available from Covidien llc on request. To verify the accuracy, use a certified black body as specified in EN 12470-5:2003, Annex C, or use a Genius 2 Checker/Calibrator - available from Covidien llc under part number 303097.</p> <p>Clinical repeatability: meets section A.5 of EN 12470-5:2003 (E) per Covidien llc technical report. Data is available from Covidien llc on request.</p>		

Displayed Temperature Measurement Range		
Mode	Range °C	Range °F
Ear	33.0 to 42.0	91.4 to 107.6
Oral (ear + 0.6°C)	33.6 to 42.0	92.5 to 107.6
Core (ear + 1.04°C)	34.0 to 42.0	93.2 to 107.6
Rectal (ear + 1.16°C)	34.2 to 42.0	93.6 to 107.6
Caution: ASTM E1965-98 specifies 34.4°C to 42.2°C (94°F to 108°F)		

Tympanic Temperature Alarm Specifications	
Range	33.0°C to 42.0°C (91°F to 108°F)
Adjustment	0.5°C steps (33°C to 35°C) 0.1°C steps (35°C to 42°C) 1.0°F steps (91°F to 95°F) 0.2°F steps (95°F to 108°F)

CO₂

Complies with: ISO 80601-2-55:2011/EN ISO 80601-2-55:2011

Microstream CO ₂ Performance Specifications		
CO₂	Range	0 to 150 mmHg (0 to 20 kPa), or 20% CO ₂ , whichever is lower
	Accuracy	Up to 5 minutes during warmup: ±4 mmHg or 12%, whichever is greater After 5 minutes warmup: 0 to 40 mmHg (0 to 5.3 kPa): ±2.2 mmHg (±0.3 kPa) Above 40 mmHg (5.3 kPa): ±(5.5% + {0.08% per mmHg above 40 mmHg}) of reading These specifications are valid for 21% O ₂ and N ₂ balance, up to 35°C ambient temperature, up to 60 rpm in adult mode and 100 rpm in neonatal mode. Outside of these conditions the accuracy reaches at a minimum ±4 mmHg or ±12% of the reading, whichever is greater.
	Resolution	Numeric: 1.0 mmHg (0.1 kPa) Wave: 0.1 mmHg (0.01 kPa)
	Stability	Included in Accuracy specifications
AwRR	Range	0 to 150 rpm
	Accuracy	0 to 40 rpm: ±1 rpm 41 to 70 rpm: ±2 rpm 71 to 100 rpm: ±3 rpm >100 rpm: ±5% of reading

38 Specifications

Microstream CO ₂ Performance Specifications		
IPI	Range	1 to 10
	Resolution	1
Warm-up Time		5 minutes for full accuracy specification
Rise Time		190 ms for neonatal mode (measured with FilterLine H for neonatal) 240 ms for adult mode (measured with FilterLine H for adult)
Sample Flow Rate		50 + 15/-7.5 ml/minute
Gas Sampling Delay Time		Maximum: 3 seconds (2m sample lines) 6 seconds (4m sample lines)
Sound Pressure		Acoustic noise: <45 dBA
Total System Response Time		Less than the sum of the gas sampling delay time and rise time plus 1 second.

Microstream CO₂ Humidity Correction Factor

Either BTPS or ATPD can be selected as the humidity correction factor for the Microstream CO₂ readings. The formula for the correction calculation is:

$$P_{\text{BTPS}} = (P_{\text{ATPD}} \cdot 0.94) \quad \text{where:}$$

P_{BTPS} = partial pressure at body temperature and pressure, saturated

P_{ATPD} = partial pressure at ambient temperature and pressure, dry

Mainstream CO ₂ Performance Specifications		
CO ₂	Range	0 to 150 mmHg (0 to 20.0 kPa)
	Accuracy	after 2 minutes warmup: For values between 0 and 40 mmHg: ± 2.0 mmHg (± 0.29 kPa) For values from 41 to 70 mmHg: $\pm 5\%$ of reading For values from 71 to 100 mmHg: $\pm 8\%$ of reading The specifications are valid for standard gas mixtures, balance air, fully hydrated at 35°C, $P_{\text{abs}} = 760$ mmHg, flow rate = 2 l/min.
	Resolution	Numeric: 1.0 mmHg (0.1 kPa) Wave: 0.1 mmHg (0.01 kPa)
	Stability:	
	Short term drift	± 0.8 mmHg over four hours
	Long term drift	Accuracy specification will be maintained over a 120 hour period
awRR	Range	2 to 150 rpm
	Accuracy	± 1 rpm
Warm-up Time		2 minutes with CO ₂ transducer attached for full accuracy specification
Rise Time		Less than 60 ms (with adult or infant reusable or disposable adapter)
Total System Response Time		Less than the rise time plus 1 second

Sidestream CO ₂ Performance Specifications		
CO ₂	Range	0 to 150 mmHg (0 to 20.0 kPa)
	Accuracy	after 2 minutes warmup: For values between 0 and 40 mmHg: ±2.0 mmHg (±0.29 kPa) For values from 41 to 70 mmHg: ±5% of reading For values from 71 to 100 mmHg: ±8% of reading For values from 101 to 150 mmHg: ±10% of reading At respiration rates above 80 rpm, all ranges are ±12% of actual. The specifications are valid for gas mixtures of CO ₂ , balance N ₂ , dry gas at 760 mmHg within specified operating temperature range.
	Resolution	Numeric: 1.0 mmHg (0.1 kPa) Wave: 0.1 mmHg (0.01 kPa)
	Stability:	
	Short term drift	±0.8 mmHg over four hours
	Long term drift	Accuracy specification will be maintained over a 120 hour period
awRR	Range	2 to 150 rpm
	Accuracy	±1 rpm
Warm-up Time	2 minutes with CO ₂ sensor attached for full accuracy specification	
Sample Flow Rate	50 ±10 ml/minute	
Gas Sampling Delay Time	Less than 3 seconds	
Rise Time	Less than 240 ms	
Total System Response Time	Less than the sum of the gas sampling delay time and rise time plus 1 second	
Operating Temperature	0 to 40°C (32 to 100°F)	

Mainstream and Sidestream CO₂ Humidity Correction Factor

Either BTPS or ATPD can be selected as the humidity correction factor for the CO₂ readings. The formula for the correction calculation is:

$$P_{\text{ATPD}} = P_{\text{BTPS}} \cdot \frac{P_{\text{abs}}}{P_{\text{abs}} - P_{\text{H}_2\text{O}}}$$

where:

P_{BTPS} = partial pressure at body temperature and pressure, saturated

P_{ATPD} = partial pressure at ambient temperature and pressure, dry

P_{abs} = absolute pressure

$P_{\text{H}_2\text{O}}$ = 42 mmHg @35°C and 100% RH

CO ₂ Alarm Specifications	Range	Adjustment	Delay
etCO ₂ High	20 to 95 mmHg (2 to 13 kPa)	1 mmHg (0.1 kPa)	Mainstream/sidestream: less than 14 seconds M3015A/B: less than 21 seconds.
etCO ₂ Low	10 to 90 mmHg (1 to 12 kPa)		
imCO ₂ High	2 to 20 mmHg (0.3 to 3.0 kPa)	steps of 1 mmHg (0.1 kPa)	Mainstream/sidestream: less than 14 seconds M3015A/B: less than 21 seconds.

38 Specifications

CO ₂ Alarm Specifications	Range	Adjustment	Delay
awRR High	Adult/pedi: 10 to 100 rpm Neo: 30 to 150 rpm	< 20 rpm: 1 rpm steps ≥ 20 rpm: 5 rpm steps	Mainstream/sidestream: less than 14 seconds M3015A/B: less than 21 seconds.
awRR Low	Adult/pedi: 0 to 95 rpm Neo: 0 to 145 rpm		Microstream: settings ≤20 rpm: less than 8 seconds >20 rpm: less than 21 seconds Mainstream/sidestream settings ≤20 rpm: less than 4 seconds >20 rpm: less than 14 seconds
IPI Low (M3015A/B only)	Adult/pedi: 2 to 9	steps of 1	Maximum 14 seconds after displayed value goes below the low alarm limit setting.
Apnea delay	10 to 40 seconds	5 second steps	Set apnea delay time + 4 seconds (Mainstream/sidestream) or 8 seconds (Microstream with 2 m sample lines) or 11 seconds (Microstream with 4 m sample lines).

Interfering Gas and Vapor Effects on CO₂ Measurement Values

The specified deviations for mainstream and sidestream CO₂ are valid when the appropriate corrections are switched on and set correctly.

Gas or Vapor	Gas Level (% volume fraction)	Mainstream/sidestream CO ₂	Microstream CO ₂
Additional deviation due to gas interference, measured at 0 - 40 mmHg CO₂			
Nitrous Oxide	60%	±1 mmHg	±5%
Halothane	4%	±1 mmHg	±5%
Enflurane	5%	±1 mmHg	±5%
Isoflurane	5%	±1 mmHg	±5%
Sevoflurane	5%	±1 mmHg	±5%
Xenon	80%	-5 mmHg	±5%
Helium	50%	±1 mmHg	±5%
Metered dose inhaler propellants	-	not specified for use	
Desflurane	15%	+3 mmHg	±5%
Ethanol	0.1	±1 mmHg	±5%
Isopropanol	0.1	±1 mmHg	±5%
Acetone	0.1	±1 mmHg	±5%
Methane	1%	±1 mmHg	±5%

Cardiac Output / Continuous Cardiac Output

C.O./CCO Performance Specifications		
C.O. (right heart)	Range	0.1 to 20.0 l/min
	Accuracy	Instrument Specification (electrical): $\pm 3\%$ or 0.1 l/min System Specification: $\pm 5\%$ or 0.2 l/min
	Repeatability	Instrument Specification (electrical): $\pm 2\%$ or 0.1 l/min System Specification: $\pm 3\%$ or 0.1 l/min
C.O. (transpulmonary)	Range	0.1 to 25.0 l/min
	Accuracy	Instrument Specification (electrical): $\pm 4\%$ or 0.15 l/min System Specification: $\pm 5\%$ or 0.2 l/min
	Repeatability	Instrument Specification (electrical): $\pm 2\%$ or 0.1 l/min System Specification: $\pm 3\%$ or 0.1 l/min
EVLW	Range	10 to 5000 ml
	Standard Deviation	10% or 1 ml/kg
ITBV	Range	50 to 6000 ml
	Accuracy	$\pm 10\%$ or 30 ml
	Repeatability	$\pm 5\%$ or 20 ml
GEDV: Global End Diastolic Volume	Range	40 to 4800 ml
CFI: Cardiac Function Index	Range	1 to 15
PVPI: Pulmonary Vascular Permeability Index ¹	Range	0 to 9.9
GEF: Global Ejection Fraction ¹	Range	0 to 100%
RLShnt: Right-Left-Shunt Fraction ¹	Range	0 to 100%
CCO	Range	0.1 to 25.0 l/min
	Standard Deviation	10% or 0.3 l/min
	Display Update	2 seconds nominal
CCI: Continuous Cardiac Index	Range	0.1 to 15 l/min/m ²
SV: Stroke Volume	Range	1 to 250 ml
SI: Stroke Volume Index	Range	1 to 125 ml/m ²
SVV: Stroke Volume Variation	Range	0 to 50%
PPV: Pulse Pressure Variation	Range	0 to 50%
dPmax: Left Ventricular Contractility Index ¹	Range	200 to 5000
Blood Temperature	Range	17.0 to 43°C (62.6 to 109.5°F)
Injectate Temperature	Range	-1 to 30°C (30.1 to 86.0°F)

¹ Not available in the USA and territories relying on FDA market clearance.

C.O./CCO Alarm Specifications	Range	Adjustment	Delay
TBlood	17 to 43°C (63 to 109°F)	Steps of 0.5°C (17 to 35°C) Steps of 0.1°C (35 to 43°C) Steps of 1°F (63 to 95°F) Steps of 0.2°F (95 to 109°F)	10 seconds after the value exceeds the set limit
CCO	0.1 to 25.0 l/min	Steps of 0.1 l/min (0.1 to 10.0 l/min) Steps of 0.5 l/min (10.0 to 25.0 l/min)	10 seconds after the value exceeds the set limit
CCI	0.1–15 l/min/m ²	Steps of 0.1 l/min/m ² (0.1 to 7.0 l/min/m ²) Steps of 0.5 l/min/m ² (7.0 to 15.0 l/min/m ²)	10 seconds after the value exceeds the set limit

Intravascular Oxygen Saturation

Performance Specifications		
SO ₂ , SvO ₂ , ScvO ₂	Range	10% to 100%
	Accuracy	±2% (i.e. ±2 units), 1 standard deviation over 40% to 100% ¹ range.
	Resolution	1%
Stability (system)		Drift <2% over 24 hours
Response Time (10 % to 90 %)		5 seconds

¹ The accuracy specification for Edwards Lifesciences' Philips-compatible catheters has been verified in the saturation range 40%-95%.

Alarm Specifications	Range	Adjustment	Delay
SO ₂ , SvO ₂ , ScvO ₂	10% to 100%	1%	max. 15 +4 seconds after value exceeds the set limit range

EEG

M1027B complies with IEC 60601-2-26:2012/EN 60601-2-26:2015.

EEG Performance Specifications		
Total Power (TP)	0 to 99.99 nW	
Spectral Edge Frequency (SEF)	0 to 30 Hz	
Mean Dominant Frequency (MDF)	0 to 30 Hz	
Peak Power Frequency (PPF)	0 to 30 Hz	
Delta	0 to 100%	
Theta	0 to 100%	
Alpha	0 to 100%	
Beta	0 to 100%	
Burst Suppression Ratio	0 to 100%	
Input Signal Range	1 mV _{p-p}	
Differential Input Impedance	>15 M Ω @ 10 Hz	
Max. DC Input Offset Voltage	\pm 320 mV	
Input Protection	Against defibrillation (5 kV) and electrosurgery	
Common Mode Rejection	>105 dB @ 5 k Ω imbalance and 60 Hz	
Noise	<0.4 μ V _{rms} (1 to 30 Hz)	
Electromagnetic Susceptibility	<10 μ V _{p-p} @ 3 V/m and 3V _{RMS} , respectively	
Electrode Impedance Measurement	Range	0 to 30 k Ω
	Accuracy	\pm 1 k Ω or \pm 10%, whichever is greater
Bandwidth	0.5 Hz to 50 Hz (-3 dB)	
Low Filter Cut-Off Frequencies	0.5, 1.0, 2.0, and 5.0 Hz (12 dB/octave)	
High Filter Cut-Off Frequencies	15 Hz, 30 Hz, 50 Hz (65 dB/octave)	

BIS

M1034B complies with IEC 60601-2-26:2012/EN 60601-2-26:2015.

BIS Performance Specifications	
Bispectral Index (BIS) Range	0 - 100
Signal Quality Index (SQI) Range	0 - 100%
EMG Range	0 - 100 dB
Suppression Ratio (SR)	0 - 100%
Spectral Edge Frequency (SEF)	0.5 - 30.0 Hz
Total Power (TP)	0 - 100 dB
Bursts	0 - 30 /minute
Asymmetry (ASYM L/R)	-100 - 100% (in relation to selected hemisphere)
Noise	<0.3 μ V RMS (2.0 μ V peak-to-peak)
Wave Scale	<i>With gridlines on:</i> \pm 25 μ V, \pm 50 μ V, \pm 100 μ V, \pm 250 μ V <i>With gridlines off:</i> 50 μ V, 100 μ V, 200 μ V, 500 μ V
Bandwidth	0.25 - 100 Hz (-3 dB)
High Pass Filters	0.25 Hz, 1 Hz, 2 Hz (-3 dB)

38 Specifications

BIS Performance Specifications	
Low Pass Filters	30 Hz, 50 Hz, 70 Hz, 100 Hz (-3 dB)
Notch Filters (for line frequency)	50 Hz, 60 Hz
Impedance Measurement Range	0 to 999 k Ω

BIS Alarm Specifications	Range	Adjustment	Alarm Delay
BIS High/Low Alarm	0 - 100	1	Max. 2 seconds

NMT

NMT Performance Specifications		
Stimulation Output	Current Pulse	100, 200, or 300 μ secs; monophasic rectangle pulse
	Current Range	5 to 60 mA in increments of 5 mA
	Current Accuracy	\pm 5% or \pm 2 mA, whichever is greater
	Maximum Skin Resistance	3 k Ω
	Maximum Output Voltage	300 V \pm 10%
Single Twitch Stimulation Mode	Twitch	0 to 200% (resolution: 1%)
	Repeat Time	Manual, or 1 sec, 12 sec, 30 sec
	Minimum Recovery Time	None
Train-Of-Four Stimulation Mode	TOF Count (TOFcnt)	0 to 4 (resolution: 1)
	TOF Ratio (TOFrat)	5 to 150% (resolution: 1)
	Repeat Time	Manual, or 12 sec, 30 sec, 1 min, 5 min, 10 min, 15 min, 30 min, 60 min
	Minimum Recovery Time	10 sec
Post-Tetanic-Count Stimulation Mode	PTC	0 to 20 (resolution: 1)
	Repeat Time	Manual
	Minimum Recovery Time	2 min
Double-Burst Stimulation Mode	Repeat Time	Manual
	Minimum Recovery Time	20 sec

NMT Alarm Specifications	Range	Alarm Delay
** TOFcnt High	0, 1, 2, 3 TOF Counts	Max. 4 sec system delay after value goes above the high alarm limit setting

G7m Gas Analyzer

The G7m Gas Analyzer (866173) complies with ISO 80601-2-55: 2011.

G7m Gas Analyzer Performance Specifications		
General specifications	Sample flow rate	200 ml/min \pm 20 ml/min
	Gas sampling delay	<5 seconds
	Leakage	<5 ml/min
	Air ingress ion	<40 ml per zero

G7m Gas Analyzer Performance Specifications		
CO ₂	Range	0 to 13.6 vol%
	Accuracy	±(0.43 vol% +8% relative)
	Resolution	1 mmHg
	Rise time	300 ms typical
O ₂	Range	0 to 100 vol%
	Accuracy	±(2.5 vol% +2.5% relative)
	Resolution	1 vol%
	Rise Time	500 ms typical
N ₂ O	Range	0 to 100 vol%
	Accuracy	±(2.0 vol% +8% relative)
	Resolution	1 vol%
	Rise time	300 ms typical
Halothane Enflurane Isoflurane Sevoflurane Desflurane	Range	Halothane: 0-8.5 vol% Enflurane: 0-10.0 vol% Isoflurane: 0-8.5 vol% Sevoflurane: 0-10.0 vol% Desflurane: 0-20.0 vol%
	Accuracy	±(0.15 vol% +15.0% relative)
	Resolution	0.05 vol%
	Rise Time	450 ms typical
	Agent ID response time	15 seconds for first agent 20 seconds for second agent
	First agent detection threshold	maximum 0.3 vol%
	Second agent detection threshold	Maximum 0.4 vol%, except when the first agent is Desflurane 10 vol% of the current Desflurane concentration
awRR	Range	0 to 100 l/min
	Accuracy	±1 for respiration rates 0 to 80 unspecified if > 80
	Resolution	1.0
	Detection Criteria	adaptive threshold
Total System Response Time	Less than the sum of the gas sampling delay time and rise time plus 1 second	

Accuracy specifications refer to BTPS for mmHg and kPa, and to ATPS for vol%.

The influence of respiration rate and the inspiratory/expiratory time ratio (I:E) on the accuracy of end tidal gas readings was determined from the measured concentration gradients in a simulated breathing system with rectangular concentration transitions.

The end tidal gas concentration is the value of a specific gas that is measured at the time of the maximum CO₂ concentration in the expiration phase. This time is determined for each breath individually.

The maximum data sample rate that can be displayed on the monitor for gas waves is 1 sample per 32 ms. The actual data sample rate displayed is dependent on the wave speed set at the monitor.

Humidity Correction

For CO₂ the humidity correction can be set to **Wet** or **Dry**.

Wet: p [mmHg] = c [Vol%]* $(p_{abs} - p_{H_2O})/100$. This measurement unit corresponds to the setting: ambient temperature and pressure, saturated (ATPS)

Dry: p [mmHg] = c [Vol%]* $p_{abs}/100$

Where p = partial pressure, c = gas concentration, p_{abs} = pressure in breathing circuit, and p_{H_2O} = 21 mmHg, partial pressure of water vapor of exhaled gas (23°C, 100% rh).

For all other gases (except CO₂) the readings are always given as dry values.

Alarm Specifications

Alarm	Alarm Limit Range	Delay
etCO ₂ High	20 to 76 mmHg (2.7 to 10.1 kPa)	19 seconds, if no automatic zero calibration occurs within that time (total delay = gas sampling delay + programmed alarm delay + system delay <= 5 sec + 10 sec + 4 sec).
etCO ₂ Low	10 to 75 mmHg (1.3 to 10.0 kPa)	
imCO ₂ High	2 to 20 mmHg (0.3 to 2.7 kPa)	
inO ₂ High	19 to 100 vol%	
inO ₂ Low	18 to 99 vol%	
inN ₂ O	0 to 82 vol%	
in/et HAL/ISO/ENF High	0.1 to 7.5 vol%	
in/et HAL/ISO/ENF Low	0.0 to 7.4 vol%	
in/et SEV High	0.1 to 9.0 vol%	
in/et SEV Low	0.0 to 8.9 vol%	
in/et DES High	0.2 to 20.0 vol%	
in/et DES Low	0.0 to 19.8 vol%	
awRR High	Neonatal: 30 to 60 rpm Adult and Pediatric: 10 to 60 rpm	10 seconds
awRR Low	Neonatal: 0 to 55 rpm Adult and Pediatric: 0 to 55 rpm	< 20 rpm: 0 seconds > 20 rpm: 10 seconds
Apnea Delay	10 to 40 seconds	within 2 sec after alarm criterion is met (no detected breath within the adjusted delay time), if no automatic zero calibration occurs

Interfering Gases and Vapors

At the gas levels listed below the cross-sensitivity is lower than 0.2 vol%.

Gas or Vapor	Gas Level in % volume fraction
Xenon	Not for use with Xenon
Helium	Not for use with Helium
Metered dose inhaler propellants	Not for use with metered dose inhaler propellants
Ethanol	0.3
Isopropanol	1.0
Acetone	0.1
Methane	0.1

Safety and Performance Tests

You must observe any national regulations on the qualification of the testing personnel and suitable measuring and testing facilities. See the maintenance section for a list of required tests. Safety and performance tests, and what to do if the instrument does not meet these specifications, are described in the Service Guide.

Electromagnetic Compatibility (EMC) Specifications

Take special precautions regarding electromagnetic compatibility (EMC) when using medical electrical equipment. You must operate your monitoring equipment according to the EMC information provided in this book.

WARNING

Do not expose the equipment to X-ray or strong magnetic fields (MRI).

The monitor should not be used next to or stacked with other equipment. If you must stack the monitor, check that normal operation is possible in the necessary configuration before you start monitoring patients.

Radio frequency interference: Portable and mobile radio frequency (RF) communications equipment (for example cell phones and wireless LAN) including their antennas can affect the monitor, potentially leading to safety risks. Do not use portable radio frequency (RF) communications equipment closer than 30 cm (12 in) to the monitor and the specified accessories.

This monitor generates, uses and radiates radio frequency energy, and if it is not installed and used in accordance with its accompanying documentation, may cause interference to radio communications.

The monitor, equipped with a wireless network interface, intentionally receives RF electromagnetic energy for the purpose of its operation. Therefore, other equipment may cause interference, even if that other equipment complies with CISPR emission requirements.

Electromagnetic compatibility: Using accessories other than those specified may result in increased electromagnetic emission or decreased electromagnetic immunity of the monitoring equipment.

Based on their emission characteristics, MX750/850 patient monitors are suitable for use in hospitals only (CISPR 11 class A). If they are used in a residential environment (for which CISPR 11 class B is usually required), these monitors might not offer adequate protection to radio frequency communication services. You might need to take mitigation measures, such as relocating or reorienting the equipment.

Essential Performance Characteristics

This section defines the Essential Performance for IntelliVue patient monitors, in combination with Multi-Measurement Modules, Module Racks, Measurement Extensions and measurement (plug-in) modules.

Under normal and single fault conditions and when operating under non-transient electromagnetic phenomena according to IEC 60601-1-2, either at least the performance listed in the following table is provided or failure to provide this performance is readily identifiable by the user. For example, identifiers are technical alarms, no waveforms and/or numeric values, complete failure of the monitor, readily identifiable distorted signals, and so on.

The following are non-transient electromagnetic phenomena according to IEC 60601-1-2:

- Radiated radio frequency (RF) electromagnetic fields
- Conducted disturbances induced by RF fields
- Power frequency magnetic fields
- Voltage dips
- Proximity electromagnetic fields from RF wireless communication equipment

Parameter	Performance
General	No interruption or cessation of current operating mode (for example, no reboot, display OK). No spontaneous operation of controls (for example, no activation of touchscreen without user interaction).
	Visual and audible alarm indications (monitor internal or Active Display).
BIS	Measurement of Bispectral Index (BIS).
	Alarming on BIS limit violation.
C.O./C.C.O	Measurement of blood temperature within $\pm 0.3^{\circ}\text{C}$.
	Alarming on blood temperature limit violations.
ECG	Measurement of heart rate within $\pm 10\%$ or ± 5 bpm, whichever is greater.
	Alarming on Asystole, or heart rate limit violation within specified delay time.
	Detection of VFIB and alarming on it.
	ECG-Out Signal delay ≤ 35 ms.
EEG	Measurement of spectral edge frequency, mean dominant frequency, peak power frequency, total power, as well as the percentage of power in the alpha, beta, theta, and delta bands.
Intravascular Oxygen Saturation	Measurement of intravascular oxygen saturation within specified accuracy/ error limits.
	Alarming on intravascular oxygen saturation limit violation.
Invasive Pressure	Measurement of systolic, diastolic and mean blood pressure within $\pm 4\%$ or ± 4 mmHg, whichever is greater, and pulse rate within $\pm 10\%$ or ± 5 bpm, whichever is greater.
	Alarming on systolic, diastolic and mean blood pressure limit violations.
Masimo SET	SpO ₂ (Functional Oxygen Saturation) Accuracy shall be root-mean-square difference of less than or equal to 2.0% SpO ₂ over the range of 70% to 100% SaO ₂ without Motion.
	SpO ₂ Accuracy shall be root-mean-square difference of less than or equal to 3.0% SpO ₂ over the range of 70% to 100% SaO ₂ with Motion.
	BPM (pulse rate) Accuracy shall be root-mean-square difference of less than or equal to 3 bpm over the range of 25-240 bpm without Motion.
	Alarming on oxygen saturation and pulse rate limit violation.

Parameter	Performance
Masimo rainbow SET	SpO ₂ (Functional Oxygen Saturation) Accuracy shall be root-mean-square difference of less than or equal to 2.0% SpO ₂ over the range of 70% to 100% SaO ₂ without Motion.
	SpO ₂ Accuracy shall be root-mean-square difference of less than or equal to 3.0% SpO ₂ over the range of 70% to 100% SaO ₂ with Motion.
	SpO ₂ Accuracy shall be root-mean-square difference of less than or equal to 3.0% SpO ₂ over the range of 60% to 80% SaO ₂ with Motion.
	SpCO (carboxyhemoglobin saturation) Accuracy shall be root-mean-square difference of less than or equal to 3.0% SpCO over the range of 0% to 100% without Motion.
	SpMet (methemoglobin saturation) Accuracy shall be root-mean-square difference of less than or equal to 1.0% SpMet over the range of 0% to 100% without Motion.
	SpHb (total hemoglobin) Accuracy shall be root-mean-square difference of less than or equal to 1.0% SpHb over the range of 0-25 g/dl without Motion.
	RPM (respiratory rate) Accuracy shall be root-mean-square difference of less than or equal to 1 rpm over the range of 0-70 rpm without Motion.
	BPM (pulse rate) Accuracy shall be root-mean-square difference of less than or equal to 3 bpm over the range of 25-240 bpm without Motion.
	Alarming on limit violation of the respective parameters.
NBP	Measurement of systolic, diastolic and mean blood pressure and pulse rate within specified accuracy/error limits.
	Automatic cycling.
	Alarming on systolic, diastolic and mean blood pressure limit violations.
NMT	Measurement of Train-Of-Four, Post-Tetanic-Count, Double-Burst and Single-Twitch stimulation responses.
	Alarming on TOF Count limit violation.
Respiration	Measurement of respiration rate within specified accuracy/error limits.
	Alarming on apnea and on respiration rate limit violation.

Parameter	Performance
Respiratory Gases (CO ₂ , O ₂ , N ₂ O, Anesthetic Agents)	Measurement of respiratory gases within the following measurement accuracy ranges: Halogenated agent: ± (0.2% absolute + 15% of reading) CO₂: ± (0.43% absolute + 8% of reading) Nitrous oxide: ± (2.0% absolute + 8% of reading) O₂: ± (0.25% absolute + 2.5% of reading)
	Measurement of airway respiration rate within specified accuracy/error limits.
	Alarming on apnea, airway respiration rate and respiratory gas limit violation.
SpO ₂	Measurement of oxygen saturation within 4% _{RMS} over the range from 70 to 100% and pulse rate within ±10% or ±5 bpm, whichever is greater.
	Alarming on oxygen saturation and pulse rate limit violation.
tcpO ₂ / tcpCO ₂	Measurement of partial pressure O ₂ within ±6 mmHg over the range from 40 to 100 mmHg and partial pressure CO ₂ within ±6 mmHg over the range from 30 to 60 mmHg.
	Alarming on transcutaneous partial pressure O ₂ and CO ₂ limit violation.
Temperature	Measurement of temperature within ±0.3°C.
	Alarming on temperature limit violation.
Tympanic Temperature	Measurement of temperature within ±0.3°C.
	Alarming on temperature limit violation.

When operating under transient electromagnetic phenomena according to IEC 60601-1-2, either at least the performance listed in the following table is provided or failure to provide this performance is readily identifiable by the user. For example, identifiers are technical alarms, no waveforms and/or numeric values, complete failure of the monitor, readily identifiable distorted signals, and so on.

The following are transient electromagnetic phenomena according to IEC 60601-1-2:

- Electrostatic Discharge (ESD)
- Electrical Fast Transients/Bursts
- Surges
- Voltage interruptions
- Electrosurgery
- Defibrillation

Parameter	Performance
All	After electrostatic discharge, fast transients / bursts, surges, electro surgery interference and defibrillation the equipment returns to previous operation mode within 30 seconds (tcpO ₂ /tcpCO ₂ : 60 seconds) without operator intervention and without loss of any stored data.
	After voltage interruptions the equipment returns to previous operating mode without operator intervention and without loss of any stored data.

NOTE

Some standards of the IEC 60601 family (for example IEC 60601-2-49, IEC 60601-2-27, and so on) may specify additional essential performance or shorter recovery times for defibrillation.

Restart time

After a power interruption, an ECG wave will be shown on the display after 30 seconds maximum. If an X2/X3 is connected to a host monitor, it can take up to a maximum of 45 seconds until the ECG wave is shown.

Default Settings Appendix

This appendix documents the most important default settings of your monitor as it is delivered from the factory. For a comprehensive list and explanation of default settings, see the Configuration Guide supplied with your monitor. The monitor's default settings can be permanently changed in Configuration Mode.

NOTE

If your monitor has been ordered pre-configured to your requirements, the settings at delivery will be different from those listed here.

Alarm and Measurement Default Settings

The default wave speed for all measurements except Respiration is 25 mm/sec. For Respiration the default wave speed is 6.25 mm/sec.

In the following tables, settings may be entered only once per table row if they are the same for all patient categories.

There are two standard Adult profiles, A and B. Some measurements have different default settings for the two profiles. This mainly affects alarm limits and some alarm settings. Profile A then uses the established defaults from the IntelliVue monitor family and profile B uses wider default settings more tolerant of differences in patient status.

Alarm Default Settings

Alarm Settings	Factory Defaults
Alarm Volume	5
Alarms Off	2 min
Pause Al. 5min	Enabled
Pause Al. 10min	Enabled
Auto Alarms Off	Off
AlarmOffReminder	Off
Visual Latching	Red&Yellow
Audible Latching	Red&Yellow
Alarm Reminder	On
Reminder Time	3 min
Alarm Sounds	Traditional
Alarm Low	4
Red Alarm Volume	AlarmVol. +2
Yell.AlarmVolume	AlarmVol. +0
INOP Volume	AlarmVol. +0

Alarm Settings	Factory Defaults
AutoIncrease Vol	2 Steps
IncreaseVolDelay	20 sec
Keep Blinking	No
Relay1 Sensitiv.	R&Y&C
Relay2 Sensitiv.	Red&Yellow
Relay3 Sensitiv.	Red
CyanRelayLatency	5 sec
Yel.RelayLatency	2 sec
Alarm Text	Standard
NoCentrMonMinVol	On
Numeric Blinking	Enhanced

ECG, Arrhythmia, ST and QT Default Settings

ECG Settings	Factory Defaults H1x/H2x/H4x			Factory Defaults H3x (where different from H1x/H2x/H4x)		
	Adult A/B	Pedi	Neo	Adult	Pedi	Neo
High Limit	120 bpm/ 140 bpm	160 bpm	200 bpm			
Low Limit	50 bpm	75 bpm	100 bpm			
ECG/Arrhy Alarms	On	On	On			
Alarm Source	Auto	Auto	Auto	Auto		
ECG	On	On	On			
QRS Volume	1	1	1			
Primary Lead	II	II	II			
Secondary Lead	V	V	V			
Analysis Mode	Multi Lead	Multi Lead	Multi Lead			
Lead Placement	Standard	Standard	Standard			
Mod.LeadPlacment	Off	Off	Off			
Filter	Monitor	Monitor	Monitor	Filter		
AutoFilter	Off	Off	Off			
Default ECG Size	Size x1	Size x1	Size x1			
Color	Green	Green	Green			
Asystole Thresh.	4.0 sec	4.0 sec	3.0 sec			
Δ ExtrTachy	20 bpm	20 bpm	20 bpm			
Tachy Clamp	200 bpm	220 bpm	240 bpm			
Δ ExtrBrady	20 bpm	20 bpm	20 bpm			
Brady Clamp	40 bpm	40 bpm	50 bpm	40 bpm	60 bpm	80 bpm
ECG Alm Off INOP	Cyan	Cyan	Cyan			
Fallback	On	On	On			
Alarms Off	Enabled	Enabled	Enabled			

ECG Settings	Factory Defaults H1x/H2x/H4x			Factory Defaults H3x (where different from H1x/H2x/H4x)		
	Adult A/B	Pedi	Neo	Adult	Pedi	Neo
AlarmSource Sel.	Enabled	Enabled	Enabled			
Va Lead	V2	V2	V2			
Vb Lead	V5	V5	V5			
SyncPulse Sensit	Medium	Medium	Medium			
SyncPulse Marker	On	On	On			
PulseAlarms Tele	Enabled	Enabled	Enabled			

Arrhythmia Default Settings

Arrhythmia Settings	Factory Defaults H1x/H2x/H4x			Factory Defaults H3x (where different from H1x/H2x/H4x)		
	Adult A/B	Pedi	Neo	Adult	Pedi	Neo
Arrhythmia	On	On	Off	Off	Off	Off
Pause Threshold	2.0 sec	2.0 sec	1.5 sec			
VTach HR	100	120	150			
VTach Run	5	5	5			
Vent Rhythm	14	14	14			
SVT HR	180	200	210			
SVT Run	5	5	5			
PVCs/min	10	5	5			
Non-Sustain	On	On	On			
Vent Rhythm	On	On	On			
Run PVCs	On	On	On			
Pair PVCs	On/Off	On	On	Off	Off	Off
R-on-T PVCs	On/Off	On	On	Off	Off	Off
V. Bigeminy	On/Off	On	On	Off	Off	Off
V. Trigeminy	On/Off	On	On	Off	Off	Off
PVCs/min	On/Off	On	On	Off	Off	Off
Multif. PVCs	On/Off	On	On	Off	Off	Off
Pacer n.Cap	On	On	On			
Pacer n.Pac	On	On	On			
Pause	On	On	On	Off	Off	Off
Missed Beat	On	On	On	Off	Off	Off
SVT	On	On	On			
Afib	On	On	On			
Irregular HR	On/Off	On	On	Off	Off	Off
HR Alarms	Short Yellow	Short Yellow	Short Yellow			
TimeOut 1st	3 min	3 min	3 min			
TimeOut 2nd	10 min	10 min	10 min			

Arrhythmia Settings	Factory Defaults H1x/H2x/H4x			Factory Defaults H3x (where different from H1x/H2x/H4x)		
	Adult A/B	Pedi	Neo	Adult	Pedi	Neo
Cardiotach Msg	Yes	Yes	Yes			
Some ECG AI INOP	On	On	On	Off	Off	Off

ST and QT Default Settings

Lead-independent ST Settings	Factory Defaults		
	Adult	Pedi	Neo
ISO/J Point detection	Auto	Auto	Auto
Alarms (ST)	On	On	On
STE	Off	Off	Off
Alarms (STE)	On	On	On
ST Analysis	On	Off	Off
ST-Index	Off	Off	Off
ISO Point	-80 ms	-80 ms	-80 ms
J Point	48 ms	48 ms	48 ms
ST Offset	J+60	J+60	J+60

ST Settings - Lead I, II, III, V, aVR, aVL, V1-6, MCL	Factory Defaults		
	Adult	Pedi	Neo
ST (Label) High Alarm Limit	+1.0 mm	+1.0 mm	+1.0 mm
ST (Label) Low Alarm Limit	-1.0 mm	-1.0 mm	-1.0 mm
ST Settings - Lead V, MCL			
ST (Label) High Alarm Limit	+2.0 mm	+2.0 mm	+2.0 mm
ST (Label) Low Alarm Limit	-2.0 mm	-2.0 mm	-2.0 mm
STE Settings - Limb leads			
STE Male Limb, Alarm Limit	1.0 mm	1.0 mm	1.0 mm
STE Female Limb, Alarm Limit	1.0 mm	1.0 mm	1.0 mm
ST Settings - lead V2, V3			
STE Male V2,V3, Alarm Limit			
STE Female V2,V3, Alarm Limit			
STE Settings - V1, V4-V6			
STE Male V1,V4-6, Alarm Limit	1.0 mm	1.0 mm	1.0 mm
STE Fem. V1,V4-6, Alarm Limit	1.0 mm	1.0 mm	1.0 mm

QT Settings	Factory Defaults		
	Adult	Pedi	Neo
QT Lead	All	All	All
QTc High Limit	500 ms	480 ms	460 ms
Δ QTc High Limit	60 ms	60 ms	60 ms
QTc High Alarm	On	On	On
Δ QTc High Alarm	On	On	On
QT Analysis	Off	Off	Off
QTc Formula	Bazett	Bazett	Bazett

Pulse Default Settings

Pulse Settings	Factory Defaults H1x/H2x/H4x			Factory Defaults H3x (where different from H1x/H2x/H4x)		
	Adult	Pedi	Neo	Adult	Pedi	Neo
Alarm Source	Auto	Auto	Auto	Auto	Auto	Auto
Pulse (source label)	On	On	On			
System Pulse	SpO ₂	SpO ₂	SpO ₂	Auto	Auto	Auto
Alarms Off	Enabled	Enabled	Enabled			
AlarmSource Sel.	Enabled	Enabled	Enabled			

Pulse Alarm Settings	Factory Defaults H1x/H2x/H4x			Factory Defaults H3x (where different from H1x/H2x/H4x)		
	Adult	Pedi	Neo	Adult	Pedi	Neo
Pulse Alarms ¹	On	On	On			
High Limit	120 bpm	160 bpm	200 bpm			
Low Limit	50 bpm	75 bpm	100 bpm			
Δ ExtrBrady	20 bpm	20 bpm	20 bpm			
Brady Clamp	40 bpm	40 bpm	50 bpm	40 bpm	60 bpm	80 bpm
Δ ExtrTachy	20 bpm	20 bpm	20 bpm			
Tachy Clamp	200 bpm	220 bpm	240 bpm			

¹ When Pulse is not the alarm source, the alarms will be **Off**.

Pulse alarms use the settings of the currently selected Pulse alarm source.

Respiration Default Settings

Respiration Settings	Factory Defaults H1x/H2x/H4x			Factory Defaults H3x (where different from H1x/H2x/H4x)		
	Adult A/B	Pedi	Neo	Adult	Pedi	Neo
High Limit	30 rpm	30 rpm	100 rpm			
Low Limit	8 rpm/5 rpm	8 rpm	30 rpm			

Respiration Settings	Factory Defaults H1x/H2x/H4x			Factory Defaults H3x (where different from H1x/H2x/H4x)		
	Adult A/B	Pedi	Neo	Adult	Pedi	Neo
Apnea Time	20 sec	20 sec	20 sec			
Alarms	On	On	On			
Resp	On	On	On	Off	Off	Off
Detection	Auto (Trigger Mode)	Auto (Trigger Mode)	Auto (Trigger Mode)			
Color	Yellow	Yellow	Yellow	White	White	White

SpO₂ Default Settings

SpO ₂ Settings	Factory Defaults		
	Adult A/B	Pedi	Neo
Mode	Continuous	Continuous	Continuous
Repeat Time	15 min	15 min	15 min
Alarms	On	On	On
QRS Volume	1	1	1
Tone Modulation	Yes	Yes	Yes
Tone Mod. Type	Enhanced	Enhanced	Enhanced
Perfusion	On	On	On
Average	10 sec	10 sec	10 sec
NBP Alarm Suppr.	On	On	On
Extd. Auto OnOff	Disabled	Disabled	Disabled
Color	Cyan (light blue)	Cyan (light blue)	Cyan (light blue)
Average in Mon.	No	No	No
Signal Quality	On	On	On

SpO ₂ Alarm Default Settings			
Setting	Adult A/B	Pedi	Neo
Desat Limit	80	80	80
Low Limit	90	90	85
High Limit	100	100	95
Desat Delay	20 sec	20 sec	20 sec
High Alarm Delay	10 sec	10 sec	10 sec
Low Alarm Delay	10 sec	10 sec	10 sec
SmartAlarmDelay (SAD)	Off/On	Off	Off
High Alarm Delay (SAD)	Short/Long	Short	Short
Low Alarm Delay (SAD)	Short/Long	Short	Short
Label	SpO ₂	SpO ₂	SpO ₂
Pulse settings			

SpO ₂ Alarm Default Settings			
Setting	Adult A/B	Pedi	Neo
Pulse (SpO ₂)	On	On	On
For all other Pulse default settings, refer to the Pulse Default Settings table.			

Masimo rainbow SET Default Settings

SpO₂

Setting	Adult A/B	Pedi	Neo
Desat Limit	80	80	80
Low Limit	90	90	85
High Limit	100	100	95
Desat Delay	20 sec	20 sec	20 sec
High Alarm Delay	10 sec	10 sec	10 sec
Low Alarm Delay	10 sec	10 sec	10 sec
Average*	10 sec	10 sec	10 sec
NBP Alarm Suppr.*	On	On	On
SpO ₂ Alarms	On	On	On
Perfusion	On	On	On
Color	Cyan	Cyan	Cyan
Extd. Auto OnOff	Disabled	Disabled	Disabled
Average in Mon.	No	No	No
Signal Quality (Also available with Masimo rainbow SET)	On	On	On
Mode*	Continuous	Continuous	Continuous
Repeat Time*	15 min	15 min	15 min
SmartAlarmDelay (SAD) (If set to On, the High/Low Alarm Limit Delay (SAD) settings are valid; if set to Off, the Standard SpO ₂ High/Low Alarm limit delay setting (0-30 sec) is valid)	Off/On	Off	Off
High Alarm Delay (SAD)	Short/Long	Short	Short
Low Alarm Delay (SAD)	Short/Long	Short	Short
Aging Time*	10 min	10 min	10 min

*Not supported with Masimo rainbow SET technology

SpO2 rainbow

Setting	Adult	Pedi	Neo
Average Average Time (rainbow)	8 sec	8 sec	8 sec
Sensitivity Algorithm Sensitivity	APOD	APOD	APOD
FastSat Algor. FastSat Algorithm	Off	Off	Off
Smart Tone	Off	Off	Off
3D Desat Index	Off	Off	Off
Delta Threshold 3D Desat Index Threshold	4%	4%	4%
Count 3D Desat Index Count	5	5	5
Period 3D Desat Index Period	1 hr	1 hr	1 hr

Pulse

Setting*	Adult	Pedi	Neo
Pulse (SpO₂)	On	On	On
Pulse Alarms	On	On	On
High Limit	120 bpm	160 bpm	200 bpm
Low Limit	50 bpm	75 bpm	100 bpm
Δ ExtrBrady	20 bpm	20 bpm	20 bpm
Brady Clamp	40 bpm	40 bpm	50 bpm
Δ ExtrTachy	20 bpm	20 bpm	20 bpm
Tachy Clamp	200 bpm	220 bpm	240 bpm

*(The presentation may depend on whether SpO₂ is selected as the HR/PULSE source or not)

Perf rainbow

Setting	Adult	Pedi	Neo
High Limit	20.00	20.00	10.00
Low Limit	0.30	0.30	0.30
Alarms Perf alarms	Off	Off	Off
Delta % Decrease 3D Perf Delta threshold	50%	50%	50%
Duration 3D Perf Delta alarm active time	Infinite	Infinite	Infinite

PVI

Setting	Adult	Pedi	Neo
High Limit	40	40	40
Low Limit	5	5	5
Alarms PVI alarms	Off	Off	Off
PVI	On	On	On

NOTE

The PVI numeric has the same color that is configured for the SpO₂ numeric.

SpMet

Setting	Adult	Pedi	Neo
High Limit	3.0%	3.0%	3.0%
Low Limit	0.0%	0.0%	0.0%
Alarms SpMet alarms	On	On	On
SpMet	Enabled	Enabled	Enabled
Color	Yellow	Yellow	Yellow

SpCO

Setting	Adult	Pedi	Neo
High Limit	10%	10%	10%
Low Limit	0%	0%	0%
Alarms SpCO alarms	On	On	On
SpCO	Enabled	Enabled	Enabled
Color	Orange	Orange	Orange

SpHb/SpOC

Setting	Adult	Pedi	Neo
SpHb	Enabled	Enabled	Enabled
SpHb High Limit	17.0 g/dl	17.0 g/dl	17.0 g/dl
SpHb Low Limit	7.0 g/dl	7.0 g/dl	7.0 g/dl
SpHb Alarms	On	On	On
SpHb Unit	g/dl	g/dl	g/dl
Average	Medium	Medium	Medium
SpHb Precision	0.1	0.1	0.1
SpHb Cal	Arterial	Arterial	Arterial
SpHb Color	Red	Red	Red

39 Default Settings Appendix

Setting	Adult	Pedi	Neo
SpOC	On	On	On
SpOC High Limit	25 ml/dl	25 ml/dl	25 ml/dl
SpOC Low Limit	10 ml/dl	10 ml/dl	10 ml/dl
SpOC Alarms	Off	Off	Off
SpOC Color	Magenta	Magenta	Magenta

RRac

Setting	Adult A/B	Pedi	Neo
High Limit	30 rpm	30 rpm	60 rpm
Low Limit	8 rpm/5 rpm	8 rpm	30 rpm
Alarms	On	On	On
Alarm Delay	30 sec	15 sec	15 sec
Average	Slow	Slow	Slow
Pause Time	30 sec	30 sec	30 sec
Max.Extd. Update	0 min	0 min	0 min
Color	White	White	White

NBP Default Settings

NBP Settings	Factory Defaults H1x/H2x/H4x			Factory Defaults H3x (where different from H1x/H2x/H4x)		
	Adult A/B	Pedi	Neo	Adult	Pedi	Neo
Mode	Auto	Auto	Manual			
Alarms from	Sys.	Sys.	Sys.			
High Limit	160/90 (110) / 180/100 (130)	120/70 (90)	90/60 (70)	180/90 (110)		
Low Limit	90/50 (60) 100/40 (60)	70/40 (50)	40/20 (24)	70/50 (65)		
Alarms	On	On	On			
NBP	On	On	On			
Repeat Time	15 min	15 min	15 min	3 min	3 min	3 min
Pulse (NBP)	On	On	On			
Unit	mmHg	mmHg	mmHg			
Done Tone	Off	Off	Off	On	On	
Start Time	Synchronized	Synchronized	Synchronized	NotSynchron.	NotSynchron.	NotSynchron.
VP Pressure	60 mmHg	40 mmHg	30 mmHg			
Reference	Auscultatory	Auscultatory	Invasive			
Aging Time	10 min	10 min	10 min			
Color	Red	Red	Red	Magenta	Magenta	Magenta

NBP Settings	Factory Defaults H1x/H2x/H4x			Factory Defaults H3x (where different from H1x/H2x/H4x)		
	Adult A/B	Pedi	Neo	Adult	Pedi	Neo
Sequence Phase A	4 times	4 times	5 times			
Repetition time	5 min	5 min	15 min			
Sequence Phase B	4 times	4 times	5 times			
Repetition time	10 min	10 min	15 min			
Sequence Phase C	4 times	4 times	5 times			
Repetition time	15 min	15 min	15 min			
Sequence Phase D	4 times	4 times	5 times			
Repetition time	30 min	30 min	15 min			
Accelerated Msmt	Off	Off	Off			
Artifact Suppr.	Standard	Standard	Standard			

Temperature Default Settings

Temp Settings	Factory Defaults H1x/H2x/H4x			Factory Defaults H3x (where different from H1x/H2x/H4x)		
	Adult	Pedi	Neo	Adult	Pedi	Neo
Low Limit	36°C	36°C	36°C	35°C	35°C	35°C
High Limit	39°C	39°C	39°C			
Alarms	On	On	On			
Unit	°C	°C	°C			
Range	35...43	35...43	35...43			
Color	Green	Green	Green	Light Green	Light Green	Light Green

Δ Temp Settings	Factory Defaults		
	Adult	Pedi	Neo
First Temp	Trect	Trect	Trect
Second Temp	Tblood	Tblood	Tblood
ΔTemp	Off	Off	Off
Measurement	Enabled	Enabled	Enabled
Color	Green	Green	Green

Tympanic Temperature Default Settings

iTemp Settings	Factory Defaults H1x/H2x/H4x			Factory Defaults H3x (where different from H1x/H2x/H4x)		
	Adult	Pedi	Neo	Adult	Pedi	Neo
Low Limit	36°C	36°C	36°C			
High Limit	39°C	39°C	39°C			

iTemp Settings	Factory Defaults H1x/H2x/H4x			Factory Defaults H3x (where different from H1x/H2x/H4x)		
	Adult	Pedi	Neo	Adult	Pedi	Neo
Unit	°C	°C	°C			
Alarms	On	On	On			
Color	Green	Green	Green			

Invasive Pressure Default Settings

ABP, P, P1, P2, P3, P4, UAP, ART, Ao, FAP, BAP, RFP, LFP, Ppr, Ppo, Pa1, Pa2, Pa3, Pa4 Settings	Factory Defaults H1x/H2x/H4x			Factory Defaults H3x (where different from H1x/H2x/H4x)		
	Adult A/B	Pedi	Neo	Adult	Pedi	Neo
Alarms from	Sys.	Sys.	Sys.			
High Limit	160/90 (110) / 180/100 (130)	120/70 (90)	90/60 (70)	180/90 (110)		
Low Limit	90/50 (70) / 80/40 (60)	70/40 (50)	55/20 (36)	70/50 (70)		
Alarms	On	On	On			
Extreme Alarms	Disabled	Disabled	Disabled			
Δ Extreme High	15	10	5			
Δ Extreme Low	15	10	5			
Sys. High Clamp/Dia. High Clamp (Mean High Clamp)	190/100 (125)	140/80 (100)	105/75 (75)			
Sys. Low Clamp/Dia. Low Clamp (Mean Low Clamp)	80/45 (65)	60/35 (45)	45/15 (30)	65/45 (65)		
Scale	150	100	100			
Mean only	No	No	No			
Filter	12 Hz	12 Hz	12 Hz			
Mercury Cal	Yes	Yes	Yes			
Artifact Suppr.	60 sec	60 sec	60 sec			
Unit	mmHg	mmHg	mmHg			
Color	Red	Red	Red			

CVP, RAP, LAP, UVP, Pv1, Pv2, Pv3, Pv4 Settings	Factory Defaults H1x/H2x/H4x			Factory Defaults H3x (where different from H1x/H2x/H4x)		
	Adult	Pedi	Neo	Adult	Pedi	Neo
Alarms from	Mean	Mean	Mean			
High Limit	14/6 (10)	10/2 (4)	10/2 (4)			
Low Limit	6/-4 (0)	2/-4 (0)	2/-4 (0)			
Alarms	On	On	On			
Extreme Alarms	Disabled	Disabled	Disabled			
Δ Extreme High	5	5	5			

CVP, RAP, LAP, UVP, Pv1, Pv2, Pv3, Pv4 Settings	Factory Defaults H1x/H2x/H4x			Factory Defaults H3x (where different from H1x/H2x/H4x)		
	Adult	Pedi	Neo	Adult	Pedi	Neo
Δ Extreme Low	5	5	5			
Sys. High Clamp/ Dia. High Clamp (Mean High Clamp)	20/10 (15)	15/5 (10)	15/5 (10)			
Sys. Low Clamp/Dia. Low Clamp (Mean Low Clamp)	0/-5 (-5)	0/-5 (-5)	0/-5 (-5)			
Scale	30	30	30			
Mean only	Yes	Yes	Yes			
Filter	12 Hz	12 Hz	12 Hz			
Mercury Cal	Yes	Yes	Yes			
Artifact Suppr.	60 sec	60 sec	60 sec			
Unit	mmHg	mmHg	mmHg			
Color	Cyan (light blue)	Cyan (light blue)	Cyan (light blue)	Blue	Blue	Blue

PAP Settings	Factory Defaults		
	Adult	Pedi	Neo
Alarms from	Dia.	Dia.	Dia.
High Limit	34/16 (20)	60/4 (26)	60/4 (26)
Low Limit	10/0 (0)	24/-4 (12)	24/-4 (12)
Alarms	On	On	On
Extreme Alarms	Disabled	Disabled	Disabled
Δ Extreme High	5	5	5
Δ Extreme Low	5	5	5
Sys. High Clamp/Dia. High Clamp (Mean High Clamp)	45/20 (25)	65/5 (35)	65/5 (35)
Sys. Low Clamp/Dia. Low Clamp (Mean Low Clamp)	5/-5 (-5)	15/-5 (5)	15/-5 (5)
Scale	30	30	30
Mean only	No	No	No
Filter	12 Hz	12 Hz	12 Hz
Mercury Cal	Yes	Yes	Yes
Artifact Suppr.	60 sec	60 sec	60 sec
Unit	mmHg	mmHg	mmHg
Color	Yellow	Yellow	Yellow

ICP, IC1, IC2, SCP Settings	Factory Defaults		
	Adult	Pedi	Neo
Alarms from	Mean	Mean	Mean
High Limit	14/6 (10)	10/2 (4)	10/2 (4)

39 Default Settings Appendix

ICP, IC1, IC2, SCP Settings	Factory Defaults		
	Adult	Pedi	Neo
Low Limit	6/-4 (0)	2/-4 (0)	2/-4 (0)
Alarms	On	On	On
Extreme Alarms	Disabled	Disabled	Disabled
Δ Extreme High	10	10	10
Δ Extreme Low	10	10	10
Sys. High Clamp/Dia. High Clamp (Mean High Clamp)	20/10 (15)	15/5 (10)	15/5 (10)
Sys. Low Clamp/Dia. Low Clamp (Mean Low Clamp)	0/-5 (-5)	0/-5 (-5)	0/-5 (-5)
Scale	30	30	30
Mean only	Yes	Yes	Yes
Filter	12 Hz	12 Hz	12 Hz
Mercury Cal	Yes	Yes	Yes
Artifact Suppr.	60 sec	60 sec	60 sec
Unit	mmHg	mmHg	mmHg
Color	Magenta	Magenta	Magenta

IAP, UAP Settings	Factory Defaults		
	Adult	Pedi	Neo
Alarms from	Mean	Mean	Mean
Mean High	12	10	10
Mean Low	0	0	0
Alarms	On	On	On
Extreme Alarms	Disabled	Disabled	Disabled
Δ Extreme High	10	5	5
Δ Extreme Low	5	5	5
Mean High Clamp	25	20	20
Mean Low Clamp	0	0	0
Scale	30	30	30
Mean only	Yes	Yes	Yes
Filter	12 Hz	12 Hz	12 Hz
Mercury Cal	Yes	Yes	Yes
Artifact Suppr.	60 sec	60 sec	60 sec
Unit	mmHg	mmHg	mmHg
Color	Magenta	Magenta	Magenta

CPP Settings	Factory Defaults		
	Adult	Pedi	Neo
High Limit	130	100	90
Low Limit	50	40	30

CPP Settings	Factory Defaults		
	Adult	Pedi	Neo
Alarms	On	On	On
CPP	Off	Off	Off
Measurement	Enabled	Enabled	Enabled
Arterial Source	ABPm	ABPm	ABPm
Scale	105 mmHg	105 mmHg	105 mmHg
Color	Magenta	Magenta	Magenta

PPV Settings	Factory Defaults		
	Adult	Pedi	Neo
Arterial Source	ABP	ABP	ABP
PPV	Off	Off	Off
Measurement	Disabled	Disabled	Disabled

Pulse settings for all arterial pressures except P1 to P4	Factory Defaults		
	Adult	Pedi	Neo
Pulse (<Press Label>)	On	On	On

For all other Pulse default settings, refer to the Pulse Default Settings table.

Cardiac Output Default Settings

C.O. Settings	Factory Defaults H0x/H1x/H2x/H4x			Factory Defaults H3x (where different from H1x/H2x/H4x)		
	Pedi	Neo	Adult	Pedi	Neo	
Adult						
Auto-Calibration	On	On	On			
Tblood HighLimit	39.0°C	39.0°C	39.0°C			
Tblood Low Limit	36.0°C	36.0°C	36.0°C			
Tblood Alarms	On	On	On			
Temperature Unit	°C	°C	°C			
Color	Green	Green	Green	Yellow	Yellow	Yellow

CCO/CCI Settings	Factory Defaults		
	Adult	Pedi	Neo
Settings common to CCO and CCI			
Alarms from	CCO	CCO	CCO
CCO from	ABP	ABP	ABP
Color	Green	Green	Green
CCO			
Alarms	On	On	On

CCO/CCI Settings	Factory Defaults		
	Adult	Pedi	Neo
CCO High Limit	8.5 l/min	3.7 l/min	1.3 l/min
CCO Low Limit	4.0 l/min	2.6 l/min	0.3 l/min
CCI			
Alarms	On	On	On
CCI High Limit	4.3 l/min/m ²	4.3 l/min/m ²	5.2 l/min/m ²
CCI Low Limit	2.0 l/min/m ²	2.6 l/min/m ²	1.2 l/min/m ²

CO₂ Default Settings

CO ₂ Settings	Factory Defaults H1x/H2x/H4x			Factory Defaults H3x (where different from H1x/H2x/H4x)		
	Adult A/B	Pedi	Neo	Adult	Pedi	Neo
etCO ₂ Low	25	25	25			
etCO ₂ High	60	60	60			
imCO ₂ High	4	4	4			
CO ₂ Alarms	On	On	On			
Unit	mmHg	mmHg	mmHg			
Scale	50 mmHg	50 mmHg	50 mmHg			
imCO ₂	On	On	On	Off	Off	Off
N ₂ O Corr. (only M3015A/B)	Off	Off	Off			
Oxygen Corr. (only M3014A)	20%	20%	20%			
Gas Corr. (only M3014A)	Off	Off	Off			
Humidity Corr.	BTPS	BTPS	BTPS			
Max Hold	20 s	20 s	20 s			
awRR	On	On	On			
awRR Alarms	On	On	On			
High Limit (awRR)	30 rpm	30 rpm	100 rpm			
Low Limit (awRR)	8 rpm/5 rpm	8 rpm	30 rpm			
Apnea Time	20 sec	20 sec	20 sec			
IPI	On	On	Off			
Low Alarm (IPI)	Off	Off				
** IPI Low	5	5				
Color	Yellow	Yellow	Yellow	White	White	White

Intravascular Oxygen Saturation Default Settings

SO ₂ Settings	Factory Defaults		
	Adult	Pedi	Neo
Low Limit	70%	70%	70%
HR High Limit	80%	80%	80%
Alarms	On	On	On
Light Intensity	On	On	On
Color	Yellow	Yellow	Yellow
Hb/Hct Entry	Hct [%]	Hct [%]	Hct [%]
Factor Entry	Disabled	Disabled	Disabled

SvO ₂ Settings	Factory Defaults		
	Adult	Pedi	Neo
Low Limit	60%	60%	60%
High Limit	80%	80%	80%
Alarms	On	On	On
Light Intensity	On	On	On
Color	Yellow	Yellow	Yellow
Hb/Hct Entry	Hct [%]		
Factor Entry	Disabled		

ScvO ₂ Settings	Factory Defaults		
	Adult	Pedi	Neo
Low Limit	70%	70%	70%
High Limit	80%	80%	80%
Alarms	On	On	On
Light Intensity	On	On	On
Color	Yellow	Yellow	Yellow

G7m Gas Analyzer Default Settings

Gas Analyzer Settings	Factory Defaults		
	Adult	Pedi	Neo
Alarm Suppress	On	On	On
AutoStandbyAfter	120 min	120 min	120 min

CO₂ Default Settings

CO ₂ Settings	Factory Defaults		
	Adult	Pedi	Neo
etCO ₂ Alarms	On	On	On
etCO ₂ High	60 mmHg	60 mmHg	60 mmHg
etCO ₂ Low	25 mmHg	25 mmHg	25 mmHg
imCO ₂ Alarm	Off	Off	Off
imCO ₂ High	4 mmHg	4 mmHg	4 mmHg
Scale	50 mmHg	50 mmHg	50 mmHg
CO ₂	et + im	et + im	et + im
Unit	mmHg	mmHg	mmHg
Color	White	White	White
Humidity Corr.	Wet ^a	Wet	Wet

a. **Wet** corresponds to ATPS (Ambient Temperature Pressure Saturated) at ambient temperature of 23°C. **Dry** corresponds to ATPD (Ambient Temperature Pressure Dry).

awRR Default Settings

awRR settings	Factory Defaults		
	Adult	Pedi	Neo
awRR Alarms	On	On	On
High Limit	40 rpm	40 rpm	60 rpm
Low Limit	8 rpm	8 rpm	30 rpm
Apnea Time	40 sec	40 sec	40 sec
awRR	On	On	On

O₂ Default Settings

O ₂ Settings	Factory Defaults		
	Adult	Pedi	Neo
inO ₂ Alarms	On	On	On
inO ₂ High	100%	100%	100%
inO ₂ Low	18%	18%	18%
Scale	100	100	100
RespiratorySpeed	-	-	-
O ₂	et + in	et + in	et + in
Unit	%	%	%
Color	Green	Green	Green

N₂O Default Settings

N ₂ O Settings	Factory Defaults		
	Adult	Pedi	Neo
inN ₂ O Alarm	On	On	On
inN ₂ O High	80%	80%	80%
Scale	60	60	60
RespiratorySpeed	-	-	-
N ₂ O	et + in	et + in	et + in
Unit	%	%	%
Color	Blue	Blue	Blue

MAC Default Settings

MAC Settings	Factory Defaults		
	Adult	Pedi	Neo
MAC	Off	Off	Off
MACawk	Off	Off	Off
Correction	Off	Off	Off
Color	White	White	White

Agent Default Settings

Agent Settings (Label Independent)	Factory Defaults		
	Adult	Pedi	Neo
Agent Channel 1	et + in	et + in	et + in
Agent Channel 2	et + in	et + in	et + in
Agent ID	Auto	Auto	Auto

HAL Default Settings

HAL Settings	Factory Defaults		
	Adult	Pedi	Neo
inHAL Alarms	On	On	On
inHAL High	2.0%	2.0%	2.0%
inHAL Low	0.0%	0.0%	0.0%
etHAL Alarms	On	On	On
etHAL High	1.6%	1.6%	1.6%
etHAL Low	0.0%	0.0%	0.0%
Scale	2.0	2.0	2.0
RespiratorySpeed	-	-	-

39 Default Settings Appendix

HAL Settings	Factory Defaults		
	Adult	Pedi	Neo
Unit	%	%	%
Color	Red	Red	Red

ISO Default Settings

ISO Settings	Factory Defaults		
	Adult	Pedi	Neo
inISO Alarms	On	On	On
inISO High	3.0%	3.0%	3.0%
inISO Low	0.0%	0.0%	0.0%
etISO Alarms	On	On	On
etISO High	2.5%	2.5%	2.5%
etISO Low	0.0%	0.0%	0.0%
Scale	3.0	3.0	3.0
RespiratorySpeed	-	-	-
Unit	%	%	%
Color	Magenta	Magenta	Magenta

ENF Default Settings

ENF Settings	Factory Defaults		
	Adult	Pedi	Neo
inENF Alarms	On	On	On
inENF High	4.0%	4.0%	4.0%
inENF Low	0.0%	0.0%	0.0%
etENF Alarms	On	On	On
etENF High	3.3%	3.3%	3.3%
etENF Low	0.0%	0.0%	0.0%
Scale	4.0	4.0	4.0
RespiratorySpeed	-	-	-
Unit	%	%	%
Color	Orange	Orange	Orange

SEV Default Settings

SEV Settings	Factory Defaults		
	Adult	Pedi	Neo
inSEV Alarms	On	On	On
inSEV High	6.0%	6.0%	6.0%

SEV Settings	Factory Defaults		
	Adult	Pedi	Neo
inSEV Low	0.0%	0.0%	0.0%
etSEV Alarms	On	On	On
etSEV High	5.0%	5.0%	5.0%
etSEV Low	0.0%	0.0%	0.0%
Scale	6.0	6.0	6.0
RespiratorySpeed	-	-	-
Unit	%	%	%
Color	Yellow	Yellow	Yellow

DES Default Settings

DES Settings	Factory Defaults		
	Adult	Pedi	Neo
inDES Alarms	On	On	On
inDES High	15.0%	15.0%	15.0%
inDES Low	0.0%	0.0%	0.0%
etDES Alarms	On	On	On
etDES High	10.0%	10.0%	10.0%
etDES Low	0.0%	0.0%	0.0%
Scale	15.0	15.0	15.0
RespiratorySpeed	-	-	-
Unit	%	%	%
Color	Cyan	Cyan	Cyan

EEG/aEEG Default Settings

EEG Settings	Factory Defaults		
	Adult	Pedi	Neo
TP, SEF	On	On	On
MDF, PPF, Delta, Theta, Alpha, Beta, BSR	Off	Off	Off
SEF Threshold	90%	90%	90%
Numeric Average	8 sec	8 sec	8 sec
Wave Scale	100 μ V	100 μ V	100 μ V
Show Gridlines	No	No	No
Low Filter	0.5 Hz	0.5 Hz	0.5 Hz
High Filter	30 Hz	30 Hz	30 Hz
Impedance Limit	5 kOhm	5 kOhm	5 kOhm
Smoothing CSA	On	On	On

EEG Settings	Factory Defaults		
	Adult	Pedi	Neo
aEEG Scale	200 μ V	200 μ V	200 μ V
Color	Yellow	Yellow	Yellow

See also “Choosing an EEG Electrode Montage” on page 310.

BIS Default Settings

BIS Settings	Factory Defaults H0x/H1x/H2x/H4x			Factory Defaults H3x (where different from H1x/H2x/H4x)		
	Adult	Pedi	Neo	Adult	Pedi	Neo
SQI	On	On	On			
EMG	On	On	On			
SR	On	On	On			
SEF	Off	Off	Off			
TP	Off	Off	Off			
Asym	On	On	On			
Values from	Left	Left	Left			
Bursts	On	On	On	Off	Off	Off
Scale	100 μ V (or +/- 50 μ V if Show Gridlines is configured to Yes)					
Show Gridlines	No	No	No			
Filters	On	On	On			
Low Filter	2 Hz	2 Hz	2 Hz			
High Filter	70 Hz	70 Hz	70 Hz			
Notch Filter	On	On	On			
High Limit	70	70	70			
Low Limit	20	20	20			
Alarms	On	On	On			
Show ImpedValues	Off	Off	Off			
Smoothing Rate	30 sec	30 sec	30 sec	15 sec	15 sec	15 sec
Color	Yellow	Yellow	Yellow	Magenta	Magenta	Magenta

NMT Default Settings

NMT Settings	Factory Defaults		
	Adult	Pedi	Neo ¹
Stimulation	TOF	TOF	TOF
Mode	Manual	Manual	Manual
Repeat Time ^{TOF}	30 sec	30 sec	30 sec
Repeat Time ^{Twitch}	12 sec	12 sec	12 sec

NMT Settings	Factory Defaults		
	Adult	Pedi	Neo ¹
Current	50 mA	50 mA	50 mA
Pulse Width	200 µsec	200 µsec	200 µsec
Alarms	Off	Off	Off
Suppress Alarms	On	On	On
TOFcnt High Lim	3	3	3
Stimul. Modes	TOF/PTC	TOF/PTC	TOF/PTC
Value Lifetime	5 min	5 min	5 min
Color	Light Green	Light Green	Light Green

¹ The NMT Measurement may not be used for neonatal patients and is therefore not supported in the neonatal mode.

Index

#

- 10-lead placement (ECG) 157
- 12-lead placement (ECG) 157
- 3-lead placement (ECG) 155
- 5-lead placement (ECG) 155

A

- AAMI ECG lead labels 154
- abdominal breathing 200
 - and Resp electrode placement 200
- aberrantly conducted beats 170
- accessories 277, 439
 - 10-electrode cable sets 445
 - 3-electrode cable sets 444
 - 5-electrode cable sets 444
 - 6-electrode cable sets 444
 - C.O. 262, 263, 267, 460
 - CO₂ 278, 282
 - CO₂ (mainstream) 461
 - ECG 147
 - EEG 310
 - NBP 446
 - adult cuffs 448
 - comfort cuffs 446
 - disposable cuffs 448
 - multi-patient comfort cuff kits 446
 - neonatal/infant cuffs (single patient) 448
 - reusable cuffs 446
 - single patient, adult/pediatric soft cuffs 448
 - Nellcor 449
 - resp 443
 - set combiners and organizers 446
 - SpO₂ 203, 205, 449
 - Nellcor adhesive sensors (disposable) 449
 - Philips sensors (disposable) 449
 - Philips sensors (reusable) 449
 - SvO₂ 464
 - temperature 460
 - trunk cables 443
- active alarms 65
- address, Philips 468
- addressograph (printer configuration setting) 407
- adjusting ST measurement points 183
- adjusting wave scale (pressure) 252
- adjusting wave size (CO₂) 284
- admitting a patient
 - editing information 124
 - quick admit 123
- advanced event surveillance 361
- agent identification 296
 - during emergence from anesthesia 297
 - exchanging agents 297
- airway adapter 283
 - CO₂, Microstream accessory 283
- alarm latching 79, 80, 175
- alarm limits 72, 75, 408
 - checking 72
 - narrow 75
 - report 341
 - setting 72
 - ST 185
 - switching auto limits on/off 75
 - using automatic limits 75
 - wide 75
- alarm recording 389
- alarm source selection, disabled 196
- alarm suppression 207, 296
- alarms 65
 - acknowledging 69
 - active 65
 - active SpO₂ source 212
 - apnea delay 202, 285
 - apnea delay time (Resp) 202
 - arrhythmia 169
 - audible indicators 67
 - awrr limits 285
 - chaining 177
 - CO₂ specific 284
 - CO₂, apnea delay 202, 285
 - CO₂, awRR 285
 - desat, SpO₂ 211
 - effect on pressure alarms during zero 249
 - extending pause time 71
 - high priority 65
 - INOP 65
 - ISO/IEC standard 68
 - NBP source 235
 - pausing 70
 - pleth as source 212
 - recordings 81
 - red 65
 - restarting 71
 - reviewing 75
 - reviewing messages 76
 - reviewing window 76
 - selftest 80
 - silencing 69
 - SpO₂ high and low limits 211
 - SpO₂ specific 207
 - ST 185
 - suspended symbol 71
 - switching on and off 51
 - temperature 237
 - testing 80
 - tone configuration 68
 - traditional 68
 - volume, changing 68
 - yellow 65
- analog output 472
 - ECG 147
 - pressure 245
- annotating events 371
- annotation 371
- apnea alarm delay 202, 285, 296
- apnea alarm delay time (Resp) 202
- apnea alarms 202, 301
 - and Resp detection modes 201
- arrhythmia 169
 - aberrantly conducted beats 170
 - analysis, how it works 169
 - atrial fibrillation and flutter 170
 - beat labels 171
 - initiating learning 174
 - intermittent bundle branch block 171
 - learning during ventricular rhythm 174
 - levels of analysis 164, 169
 - monitoring non-paced patients 170
 - monitoring paced patients 170
 - options 169
 - relearning 173, 174
 - relearning and lead fallback 174
 - status messages 172
 - switching on/off 75
 - understanding the display 171
- arrhythmia alarms 65, 174, 175, 177, 178
 - adjusting alarm limits 175
 - all yellow on/off 175
 - chaining 177
 - latching 79, 80
 - multiple 177
 - PVC-related alarms 178
 - sinus and SV rhythm ranges 494
 - switching on/off 75
 - timeout periods 176
- arrhythmia monitoring 167
 - and defibrillation 167

- arrhythmia options 164
- arrhythmia relearning 159
 - with EASI INOP 159
- arterial catheter constant (PiCCO) 263
- arterial pressure source 254
- arterial pulsation 203
- artifact suppression (pressure) 253
- Aspect Medical Systems Inc 468
- ATPD correction (Ambient Temperature Pressure Dry) 295
- atrial fibrillation and flutter 170
- audible latching (arrhythmia alarms) 175
- auto alarm limits 75
 - switching on/off 75
- auto detection mode (Resp) 200
- auto ECG wave gain (recordings) 391
- auto window (care groups) 145
- autofilter 151
- automatic arrhythmia relearn 174
- automatic default setting 50
- automatic NBP 234
- autosize 151
 - ECG wave 150
- average trend events 363
- awRR alarms 285
 - limits 285

B

- balloon inflation, wedge measurement 256
- baseline 182, 188
 - ST map, updating 188
 - ST, updating 182
- basic arrhythmia option 164, 169
- basic event surveillance 361
 - setup 263
- beat labels 171
 - arrhythmia 169
- BIS 317
 - Continuous Impedance Check 319
 - Cyclic Impedance Check 319
 - filters 321
 - Ground Check 319
 - impedance indicators 320
 - monitoring 45
 - numerics
 - on/off 321
 - safety information 167, 202, 273
 - smoothing rate 321
- blood pressure. See also NBP (noninvasive) or PRESS (invasive) 229
- BSA formula (trends) 355
- BTPS correction (Body Temperature Pressure Saturated) 295

- buffer (EEG) 312
- buffer (EEG) on reports 315
- buffer (EEG) on screen 313

C

- C.I. 259
- C.O. 259
 - accessories 277, 439
 - calibrating measurements (PiCCO) 265
 - curve alert messages 270
 - documenting measurements 269
 - editing measurements (PiCCO) 265
 - editing measurements (RH method) 268
 - flow-through method 267
 - hemocal window 262
 - hemodynamic parameters available 259
 - injectate guidelines 269
 - PiCCO method 262
 - Procedure window 260
 - prompt messages 271
 - results table 260
 - right heart thermodilution method 266
 - saving measurements (PiCCO) 265
 - setup for PiCCO method 263
 - setup for RH method 267
 - temperature unit 260
 - warning messages 272
- C.O./CCO safety information 273
- Calc Type 355
- calculating 413
 - drug infusions 413
- calculating cerebral perfusion 254
- calculating oxygen extraction 308
- calculating pulse pressure variation 254, 262
- calculating temperature difference 238
- calculations 353, 356
 - pop-up keys 44, 363
- calculations reports 356
- calculations review 356
- calculator 44
- calibrating 236
- calibrating C.O. measurements 265
- calibration 236, 250, 307
 - NBP 236
 - pressure 250
 - pressure transducer 250
- calibration status indicators (C.O.) 266
- capnography 34
 - mainstream 34
 - Microstream 34
- capturing loops 428
- carbon dioxide, see CO2 275
- cardiac output 259, 409
 - how the measurement works 229

- report 341
- cardiac overlay 199, 201
 - and Resp detection modes 201
 - when measuring Resp 199
- cardiotach alarms 164
- care groups 145
 - alarm notification 145
 - pop-up window 145
- catheter constant, setting (PiCCO) 263
- catheter preparation
 - SvO2 305
- CCO 259, 262, 263, 266
 - calibration status indicators 266
 - choosing the correct pressure source 263
 - how the measurement works 229
 - PiCCO method 262
- cerebral perfusion 254
- CFI 259
- chaining 177
- change screen menu 47
- changing ECG lead sets 153
- changing EEG wave scale 313
- changing EEG wave speed 314
- changing Resp detection mode 200
- changing Resp wave size 201
- changing Resp wave speed 201
- changing screen content 47
- changing wave scale 313
 - EEG 310
- checking paced status 148
- cleaning
 - monitoring accessories 436
 - recorder printhead 438
- clock 425
 - displaying on main screen 425
- CO2 275
 - airway adapter 283
 - alarms, apnea delay 202, 285
 - alarms, awRR 285
 - alarms, specific 284
 - awRR alarm limits 285
 - correction, humidity 284
 - correction, N2O 284
 - corrections 284
 - FilterLine 283
 - mainstream accessories 277
 - measuring mainstream 278
 - measuring Microstream 282
 - method, mainstream 275
 - method, Microstream 275
 - method, sidestream 275
 - Microstream accessories 282
 - Microstream extension 282
 - removing exhaust gases 282, 283

- troubleshooting 441
- wave scale, adjusting 284
- CO2 (mainstream) 461
 - accessories 277, 439
- CO2 (Microstream)
 - accessories 277, 439
- combi-events 370
- Compressed Spectral Arrays (CSA) 312
- computation constant (RH) 268
- configuration 45
 - drug calculator 413
 - trends database 349
- configuration mode 45
- conflict 53
 - label 53
- connecting temperature probe 237
- connection direction symbol 469
- connectors 472
- continuous cardiac output 259
- Continuous Impedance Check (BIS) 319
- conventional 12-lead ECG 157
- correcting the NBP measurement 231
- counting events 368
- CPAP (RESP) 200
- CSA (Compressed Spectral Arrays) 312
- cuff 231
 - selection, NBP 231
- current view
 - ST map 186
- curve alert messages (C.O.) 270
- Cyclic Impedance Check (BIS) 319

D

- database 368
 - events 363
 - trends 349
- date, setting 57
- default profile 50
- default settings 525
- defibrillation 167, 315
 - and arrhythmia monitoring 167
 - and ECG monitoring 167
 - during EEG monitoring 315
- delayed recording 389
- deleting events 368
- demonstration mode 45
- desat alarm, SpO2 211
- detection modes (Resp) 200
- diagnostic (ECG filter setting) 151
- discharging a patient 124
- disconnect INOPs 69
 - silencing 69

- disinfecting 436
- display 171, 181, 200
 - ECG 148
 - Resp 200
 - ST 181
- display settings 49
- disposal
 - gas cylinder 442
 - parts and accessories 442
- documenting events 371
- dPmax 259
- drug calculator 413
- dual SpO2 212
- dual Temp measurement 238
- dyshemoglobins 205
 - intravascular (SpO2) 205

E

- EASI 152, 159
 - activating 152
 - ECG monitoring 159
 - lead placement 152, 199
- EASI ECG lead labels 154
- ECG 147
 - accessories 277, 439
 - alarms off (Config Mode) 167
 - changing lead sets 153
 - choosing electrode sites 153
 - conventional 12-lead 157
 - external pacing electrodes 167
 - filter settings 151
 - fusion beat pacemakers 167
 - intrinsic rhythm 167
 - modified 12-lead 157
 - New Lead Setup 153
 - pacemaker failure 167
 - rate adaptive pacemakers 167
 - unfiltered 151
 - wave size 150
- ECG analog output 472
- ECG cable 167
 - for operating room 167
- ECG cables, connecting 147
- ECG connector 147
- ECG electrode colors 154
- ECG electrode placement 167
 - during electrosurgery 167
- ECG gain 391, 401
 - in reports 360
- ECG lead labels 154
- ECG lead placement 152
 - choosing EASI/Standard 152
- ECG leads monitored 153
- ECG report 401, 410
 - lead layout 401
- ECG safety information 167
- ECG source tracking 139
- ECG wave 150
 - autosize 151
 - calibration bar 151
- ectopic status messages (arrhythmia monitoring) 173
- editing C.O. measurements (PiCCO method) 265
- editing C.O. measurements (RH methods) 268
- EEG 310
 - accessories 277, 439
 - monitor configuration and upgrade 315
- EEG monitoring
 - about aEEG 314
 - buffer time 312
 - changing filter frequencies 314
 - changing wave scale 313
 - changing wave speed 314
 - choosing electrode montages 310
 - CSAs 312
 - electrode-to-skin impedance 311
 - gridlines 313
 - impedance quality indicators 312
 - Impedance/Montage Window 310
 - international 10-20 electrode placement system 310
 - safety information 167, 202, 273
 - setting report buffer time 315
 - setting screen buffer time 313
 - setup 263
 - skin preparation 147, 310
 - switching numerics on and off 313
- EEG wave 321
 - changing aEEG scale 315
 - changing scale 321
- electrical interference
 - during EEG monitoring 315
- electrode montage 310
 - EEG 310
- electrode placement (ECG) 147, 157
 - conventional 12-lead 157
 - modified 12-lead 157
- electrode placement (Resp) 199, 200
 - with abdominal breathing 200
 - with lateral chest expansion 200
- electrode-to-skin impedance (BIS) 319
- electrode-to-skin impedance (EEG) 311
- electrosurgery 167
 - and ECG 167
- EMC interference 202
 - Resp 200
- EMI filter for ECG 151
- end case 124

discharging a patient 124
report, printing 124
end case reports 402
setup 263
enhanced arrhythmia option 164, 169
entering values 354
calculations 353, 356
event database 368
event episode reports 401
event groups 362
event report 374
event review reports 401
event snapshots 363
event surveillance 361
options 169
events 361
annotation 371
combi-events 370
counting oxyCRG/NER events 370
event counter 368
event episode 363
event episode recording 373
event episode types 363
event episode window 370
event post-time 363
event pre-time 363
event retriggering 366
event review recording 372
event review window 369
event summary view 368
event time 363
event values 370
manual event triggers 367
events pop-up keys 363
EVLW/EVLWI 259
exchanging anaesthetic agents 297
exhaust gases, removing 282, 283
extension cable for SpO2 205
external pacing electrodes 167
and ECG monitoring 167
extreme bradycardia alarm 166, 197
extreme pressure alarms 253
extreme rate alarms 166, 197
extreme tachycardia alarm 166, 197

F

fallback (ECG) 154
FAST 203
Fourier artefact suppression
technology 203
filter (ECG filter setting) 151
filter (ECG) 151
filter frequencies (EEG) 314
FilterLine 283

CO2, Microstream accessory 283
filters 321
BIS 321
flushing invasive pressure accessories 246
functional arterial oxygen saturation 203
fusion beat pacemakers 167
and ECG monitoring 167

G

gas analyzer 287
gases measured 287
MAC calculation 297
MACawk 297
removing gas 291
returning the gas sample 291
standby mode 300
gas cylinder 442
empty, disposing of 442
gas measurement 287
GEDV/GEDVI 259
getting started 58
global trend time 350
graphic trend 341
report 341
graphic trends report 348
gridlines (EEG) 313, 321
Ground Check (BIS) 319

H

hardkeys 44
help 76
INOPS 76
hemodynamic calculations 353
hemodynamic measurement extension 34
hemodynamic parameters 259
high filter (EEG) 314
high pass filter (BIS) 321
high resolution recording 389
high-res trend event episodes 363
high-res trend waves 359
about 50
OxyCRG 359
high-res waves 360
in reports 360
recordings 81
HiResTrnd 363
see high-res trend 363
horizon trend 350
trend time 350
HR = RR (Resp) 200
HR alarms 167
when arrhythmia off 167
HR alarms off (Config Mode) 167

HR and pulse alarm source selection 196
HR from (heart rate source) 196
humidity correction 284, 295
hypotension evaluation 384

I

IEC ECG lead labels 154
impedance indicators (BIS) 320
impedance quality indicators 312
IMV (Resp) 200
infection control
disinfecting 436
sterilizing 436
Information Center 129, 130
transferring patients 129
transferring patients using IIT 130
injectate guidelines for C.O. 269
injectate volume setting (C.O.) 263
INOPs 65, 69
silencing 69
installation 472
connectors 472
integrated PC 61
intermittent bundle branch block 171
intermittent mandatory ventilation
(Resp) 200
intravascular dyshemoglobins (SpO2) 205
intrinsic rhythm 167
invasive pressure 245
in-vivo calibration, SvO2 307
iPC 61
desktop 61
input devices 62
shutting down 62
ISO point (ST) 184
ITBV/ITBVI 259

J

J point (ST) 184

K

keys 44
hardkeys 44
pop-up 44

L

label conflict resolution 53
labels 53
lactate measurement 383
latching 79, 80
alarms, behavior 80
latching arrhythmia alarms 175

lateral chest expansion (neonates) 200
 monitoring Resp 200
LCW/LCWI 259
lead fallback 174
 and arrhythmia relearning 174
lead fallback (ECG) 154
lead labels (ECG) 154
lead placement 152, 199
 activating EASI/Standard 152
 for Resp measurement 199
leads monitored (ECG) 153
Leads Off INOP (ECG) 154
levels of arrhythmia analysis 169
levels of event surveillance 361
line frequency interference (BIS) 321
loops 428, 429
 capturing 428
 loop size in window 428
 loops report 429
 source device 429
low filter (EEG) 314
low pass filter (BIS) 321
LVCI 259

M

MAC calculation 297
MACawk 297
mainstream 34
 capnography 34
mainstream CO2 277
 accessories 277, 439
 measuring 278
maintenance 439
 schedule 439
 visual inspection 439
manual detection mode (Resp) 201, 202
 and apnea alarms 202
manually triggering events 367
manufacturer's information 468
map 186
 ST 186
Mason-Likar lead system 157
max hold setting (CO2) 275
mean pressure calculation (trends) 354
measurement 51, 52
 setting up 51
 switching on and off 51
 wave speed, changing 52
measurement extension 34
 M3012A 34
 M3015A 34
measurement modules 58
measurement points, ST 183

measurement settings 49
merging patient data 134
methemoglobin (SpO2) 205
Microstream capnography 34
Microstream CO2 282
 accessories 277, 439
 measuring 278
mismatch 132
 patient data, resolving 132
modified 12-lead ECG 157
modified screen history 47
modifying screens 46
monitor 59
 starting monitoring 59
monitor (ECG filter setting) 151
monitor defaults 525
monitor revision 58
 how to find 58
monitor settings 49
monitoring 45
monitoring mode 45
mouse 40
 using 40
Multi-Measurement Module 131
 using for patient transfer 131
multi-measurement module 147
 ECG connector 147

N

N2O correction 284
narrow alarm limits 75
navigating 40
 mouse 40
 trackball 40
NBP 229
 adult cuffs 448
 alarm source 235
 ANSI/AAMI SP10-1992 229
 automatic mode, enabling 234
 calibrating 236
 comfort cuff kits 446
 comfort cuffs 446
 cuff, applying 231
 cuff, selecting 231
 cuff, tightness 231
 disposable cuffs 448
 how the measurement works 229
 measurement correction 231
 measurement limitations 230
 measurement methods, auto 230
 measurement methods, manual 230
 measurement methods, sequence 230
 measurement methods, stat 230
 measurement, starting 233
 measurement, stopping 233

neonatal cuffs (disposable) 448
oscillometric method 229
pediatric cuffs 448
preparing to measure 231
repeat time for automatic 234
repetition time, setting 234
reusable cuffs 446
single patient, adult/pediatric soft
 cuffs 448
site inspection 205
venous puncture 236
neonatal event counting 370
neonates 200
 Resp electrode placement 200
noninvasive blood pressure. See NBP 229
non-paced patients 170
 arrhythmia monitoring 167
notch filter (BIS) 321
nurse call 71

O

on screen calculator 44
operating 40
 mouse 40
 trackball 40
operating modes 45
 configuration 45
 demonstration 45
 monitoring 45
 passcode protection 45
 service 45
operating room ECG cable 167
orange ECG cable 167
organizers 446
Oridion Systems Ltd 468
Original Calc pop-up key 356
oscillometric NBP measurement
 method 229
overlapping screen trends 350
oxyCRG 359, 370
 event counting 370
OxyCRG event episodes 363
oxygen extraction 308
oxygenation calculations 353

P

pace pulse rejection (ECG) 148, 150
 about 50
 switching on/off 75
paced patients 150, 167, 170
 arrhythmia monitoring 167
 repolarization tails 150
 safety information 167, 202, 273
 setting status 167

paced status 148
 checking 72
pacemaker failure 167
paper size 401
 for reports 401
parameter scales 346
 trends 346
passcode protection 45
patient 229
 category, NBP 229
 discharge 124
 end case 124
patient demographics window 120
patient mismatch 132
patient reports 407
 contents 407
patient trends 341
 viewing 341
paused alarms 70, 71
 extending time 71
 restarting 71
PAWP 256
performance test 519
performing calculations 354
perfusion indicator 203, 205, 211
Philips contact information 468
physiological alarms 65
PiCCO method 262
 C.O. 262
 CCO 262
 setup 263
pleth alarm source 212
pleth wave 211
pleth waveform 203
pop-up keys 44, 363
 events 363
power 59
 disconnecting from 59
 mains power 59
 disconnecting from 59
PPV 254, 262
preparing skin 147
 for ECG 147
pressure 245
 alarms during zero 249
 arterial source 254
 calibration pressure 250
 cerebral perfusion, calculating 254
 wave scale 252
 wave size 150
 wedge 256
 wedge, editing 257
 zeroing the transducer 248
pressure analog output 258

pressure artifact suppression 253
pressure transducer 248
 calibration 250
 zeroing 248
previous screen 47
primary lead (ECG) 147
 selecting 147
print job 405
 suspended 405
printer 404, 405, 406
 settings 50, 139, 525
 status messages 172
 unavailable 405
printing
 C.O. measurements 269
 calculations reports 356
 event reports 371
 ST map reports 188
 status log 441
 trends reports 348
 wedge 256
priority list for trends 346
probes 237
 disposable temperature 237
profiles 49, 50
 default profile 50
 patient category 49
 swapping 50
 swapping setting block 50
protocol log 385
ProtocolWatch 381
 SSC sepsis 381
pulse 195, 196
 system pulse source 195
pulse numerics for SpO₂ 205
pulse pressure variation 254, 262
Pulsion Medical Systems AG 468
PVC-related alarms 178
PVR/PVRI 259

Q

QRS tone pitch, SpO₂ 212
QRS volume, changing 151
QT alarms 193
QT baseline 192
QT measurement algorithm 190
QT monitoring 191
 limitations 191
QT/QTc monitoring 190
quick admit 123

R

radiated field immunity 202
 Resp 200

rate adaptive pacemakers 167
 and ECG monitoring 167
RCW/RCWI 259
realtime recording 389
realtime report 409
realtime reports 401
 content 401
recorder 438
 cleaning the print head 438
recorder status messages 393
recording
 alarm 68
 annotation 371
 beat-to-beat 389
 C.O. measurements 269
 context 389
 delayed 389
 drug calculations 417
 ECG gain 391, 401
 high resolution 389
 preventing fading ink 392
 procedure 389
 realtime 389
 recording strip 391
 recording strip code 391
 ST segments 183
 starting and stopping 388
 types 389
 wave scale 252
 waveforms recorded 392
 wedge 256
recording alarms 81
recording events 371
recording strip code 391
recycling 442
reference waves, wedge measurement 256
rejecting pace pulses 148
relearning arrhythmia 173
repolarization tails 150
report 341
 cardiac output 259, 409
 event review 374
reports
 alarm limits 408
 calculations 353, 356
 choosing paper size 401
 contents 407
 drip table 417
 drug calculator 413
 ECG 147
 end case 124
 loops 428, 429
 patient trends 341
 realtime report 409
 re-routing 405
 scheduled 402

- setting up 51
- ST map 188
- stopping printouts 399
- titration table 417
- trends 348
- re-routing reports 405
- resampling vitals 356
- resolving patient mismatch 132
- resp accessories 443
- Resp alarms 202
 - apnea alarm delay time 202
- Resp detection level 202
 - and apnea detection 202
- Resp detection modes 200, 201
 - and cardiac overlay 199
- Resp display 200
- Resp monitoring 199
 - and cardiac overlay 199
- Resp safety information 202
- Resp wave 201
 - changing size 201
 - changing speed 52, 53
- respiratory loops 429
 - source device 429
- restarting paused alarms 71
- results table (C.O.) 260
- resuscitation bundle recommendations 384
- re-triggering events 366
- retrolental fibroplasia (SpO2) 211
- review 356
 - calculations 353, 356
- reviewing alarm messages 76
- reviewing alarms 75
- reviewing alarms window 76
- RH method 268
 - computation constant 268
- rhythm status messages (arrhythmia monitoring) 172
- right heart thermodilution method (C.O.) 266
- right heart thermodilution setup (C.O.) 267
- rule of six 414
- RVSW/RVSWI 259

S

- safety information 167, 202, 273
 - BIS 321
 - C.O./CCO 273
 - ECG 147
 - gas analyzer 302
 - Resp 200
- safety test 519
- same patient data merge 134

- saving C.O. measurements (RH methods) 268
- scale 150, 201
 - ECG wave 150
 - Resp wave 201
- scales 346
 - for trends waveforms 346
- scheduled reports 402
- screen trend 350
 - trend time 350
- screen trends 349
- screening criteria 383
- screens 46
 - changing content 47
 - understanding 46
 - visitors screen 48
- secondary lead (ECG) 147
 - selecting 147
- SEF numeric (BIS) 321
 - on/off 321
- selecting the primary lead (ECG) 147
- selecting the secondary lead (ECG) 147
- selftest 80
- sensor 204
 - disposable SpO2 204
- sepsis management bundle 381
 - recommendations 384
- sepsis resuscitation bundle 381, 384
 - recommendations 384
- sequence mode 235
- service mode 45
- set combiners 446
- setting the arterial catheter constant (PiCCO) 263
- setting the computation constant (RH) 268
- setting up 51
 - trends 341
- setting up reports 400
- setting up the sequence 235
- settings 50, 139, 525
 - about 50
 - default 525
 - measurement settings 49
 - monitor settings 49
 - screen settings 50
 - synchronized telemetry and monitor 139
- settings blocks 49
- severe sepsis screening 381, 383
 - criteria 383
- short yellow alarms on/off 175
- signal quality of SpO2 206
- sinus and SV rhythm ranges 494
- skin preparation 147, 310

- ECG 147
- smoothing rate (BIS) 321
- snapshots 363
 - events 363
- source device 429
 - loops 428, 429
- source tracking 139
 - ECG 147
- specifications
 - arrhythmia 169
- speed 52
 - recording 389
 - wave speed, changing 52
- SpO2 203
 - accessories 449
 - active alarm source 212
 - alarms specific to SpO2 207
 - arterial pulsation 203
 - assessing suspicious reading 206
 - calculating difference between values 212
 - connecting the cables 205
 - disposable sensors 204
 - dual SpO2 212
 - extension cable 205
 - FAST technology 203
 - Nellcor adhesive sensors (disposable) 449
 - perfusion indicator 203, 205, 211
 - Philips sensors (disposable) 449
 - Philips sensors (reusable) 449
 - pleth as alarm source 212
 - pleth wave 211
 - pleth waveform 203
 - pulse numerics 205
 - signal quality 206
 - site inspection 205
 - tone modulation 212
- SpO2 desat alarm 211
- SpO2 limit alarms 211
- Sp-vO2 308
- SQI numeric 321
 - on/off 321
- SR numeric (BIS) 321
 - on/off 321
- SSC guidelines 381
- SSC sepsis 381
- ST 179
 - adjusting alarm limits 175
 - baseline, updating 182
 - ensuring diagnostic quality 179
 - filtering 179
 - measurement points, adjusting 183
 - snippets 181
- ST display 181
- ST map 186

- baseline, updating 188
- report, printing (ST map) 188
- scale, changing 188
- task window 188
- trend view 187
- trending interval, changing 188
- ST maps 186
- ST point 184
- standard 10-lead placement 157
- standard 3-lead placement 155
- standard 5-lead placement (ECG) 155
- standardized rate 413
- starting monitoring 59
- status log 441
 - printing 441
- status messages 172
 - printer 404, 405, 406
 - recorder 438
- status messages (arrhythmia) 172, 173
 - ectopic 173
 - rhythm 172
- sterilizing 436
- stopping reports printouts 399
- suppressing alarms 207, 296
- suppressing zero calibration 301
- surgical ECG cable 167
- surviving sepsis campaign 381
- suspended alarm 71
- suspicious SpO2 reading 206
- SV/SI 259
- SvO2 305
 - accessories 277, 439
 - in-vivo calibration 307
 - monitoring 45
- SVR/SVRI 259
- system pulse 195

T

- tabular trends 343
- task window for ST map 188
- technical alarms messages 90
 - see INOPs 90
- telemetry alarms 138
 - suspending at bedside 138
- temperature 237
 - accessories 460
 - alarm settings 237
 - connecting probe to monitor 237
 - difference, calculating 238
 - dual Temp measurement 238
 - first 238
 - label 53
 - making a measurement 237
 - probe, disposable 237
 - probe, selecting 237
 - second 238
- temperature probe 237
- testing alarms 80
- time, setting 57
- timers 423, 424, 425
 - counting direction 424
 - displaying on main screen 425
 - notification 424
 - selecting label 424
 - viewing 341
- Tinj Probe Type 263
- tone configuration, alarm 68
- tone mod (SpO2) 212
- tone modulation 212
- TP numeric (BIS) 321
 - on/off 321
- trackball 40
- trackball, using 40
- trademarks 468
- transducer 17, 236, 248, 250
 - pressure, zeroing 248
- transferring centrally-monitored patients 129, 130
 - using IIT 130
- transferring patients with Multi-Measurement Module 131
- trend time 350
 - global 350
- trend view 187
 - ST map 186
- trending interval 188
 - ST map 186
- trends 341
 - automatic unit conversion 354
 - automatic value substitution 354
 - database configuration 349
 - resolution 346
 - screen trends 349
 - setting parameter scales 346
 - setup 263
 - viewing 341
- trends pop-up keys 341
- trends priority list 346
 - ST map 186
- trigger conditions 366
 - events 366
- troubleshooting 441
 - CO2 282
- trunk cables 443

U

- unfiltered ECG signal 151
- upgrading 315

- effect on EEG configuration 315

V

- V electrode placement (ECG) 156
- venous puncture 236
- ventilation calculations 353
- viewing arrhythmia waves 171
- viewing trends 341
- visible waves report 401
- visitors screen 48
- visual latching (arrhythmia alarms) 175
- vital signs 341
 - recording 348
 - report 348
- vital signs report 348
- volume 68
 - alarm 68

W

- watertrap
 - emptying 294
 - installing 292
 - removing 293
 - replace 295
- wave 52, 252, 284
 - changing speed 52, 53
 - scale (CO2) 284
 - scale (pressure) 252
 - size (CO2) 284
 - size (pressure) 252
- wave channel speed 52
- wave group speed 52
- wave scale (EEG) 321
- wave size 150
 - Resp 200
- wave size (ECG) 150
- wave speed (EEG) 314
- wave speed (Resp) 201
- wave speeds 52
 - ceg speed 52
 - wave speeds 52
 - global speed 52
 - respiratory speed 52
- wedge 256
 - balloon inflation 256
 - editing 257
 - pulmonary artery 256
 - reference waves 256
- wide alarms limits 75

Z

- zero 249
 - effect on pressure alarms 249
- zero calibration 301



zeroing 248
pressure transducer 249





Part Number 453564861711
Published in Germany 07/2019



PHILIPS

Addendum

Addendum to the Instructions for Use

This addendum provides additional information for the IntelliVue Patient Monitor Revision N.xx Instructions for Use for the following monitors:

- MX100/X3
- MX400-800
- MX750/MX850

Depending on the monitor model, some of this information may already be included in the version of the Instructions for Use you have received.

Please store this addendum with your monitor documentation.

Additional Information - Patient Alarms and INOPs Chapter

Multi-Measurement Module, Measurement Extensions and Module Rack INOPs

The following INOPs exist in addition to the ones already listed in your Instructions for Use.

INOP Message, Indication	What to do
FMS Unsupported	An FMS connected to the Measurement Link (MSL) is incompatible or not supported in this configuration. Contact your service personnel.
MMS Unsupported	An MMS connected to the Measurement Link (MSL) is incompatible or not supported in this configuration. Contact your service personnel.
MMX Unsupported	An MMX connected to the Measurement Link (MSL) is incompatible or not supported in this configuration. Contact your service personnel.
X2 Unsupported	An X2 connected to the Measurement Link (MSL) is incompatible or not supported in this configuration. Contact your service personnel.
X3 Unsupported	An X3 connected to the Measurement Link (MSL) is incompatible or not supported in this configuration. Contact your service personnel.
<Measurement Label> Unsupported	A plug-in module is incompatible or not supported in this configuration. Contact your service personnel.
FMX Unsupported	An FMX connected to the Measurement Link (MSL) is incompatible or not supported in this configuration. Contact your service personnel.
FMX Unplugged	Make sure that the Module Rack is connected to the monitor. All Module Rack measurements are off while the Module Rack is unplugged.



Additional Information - Monitoring NBP Chapter

Introducing the Oscillometric NBP Measurement

WARNING

Mastectomy or Lymph Node Clearance: Avoid applying the cuff on the side of the mastectomy or lymph node clearance, as the pressure increases the risk of lymphedema. For patients with a bilateral mastectomy or lymph node clearance, use clinical judgement to decide whether the benefit of the measurement outweighs the risk.

Additional Information - Monitoring Temperature and Monitoring Invasive Pressure Chapters

Pressure and Temperature Label Fallback Behavior

With Release N, the following new labels have been added to the extended temperature and pressure label sets:

Tbladd, Tfoley, IAP, RFP, LFP, SCP, UBP, Ppr, Ppo, Pa1, Pa2, Pa3, Pa4, Pv1, Pv2, Pv3, Pv4

These labels are only available in MX100, MX400-550, and MX750/MX850 patient monitors, FMX-4 Module Racks, and MMX and X3 Multi-Measurement Modules with SW Release N.0 or higher. An FMX, MMX or an X3 in companion mode can only be used with the new labels, if the host monitor also supports the new labels.

If you are using an X3 or MMX with the new labels to transfer patients to different units, the following conditions define whether the new labels are kept or whether the X3 or MMX falls back to an alternative label:

- whether the host monitor supports the new labels,
- the software version of the host monitor,
- the label set configuration in the X3 and the host monitor, and
- whether the measurement is activated or deactivated on an X3.

X3/MMX Fallback Behavior

The following table lists the different scenarios and the corresponding fallback behavior.

Multi-Measurement Module	Host Monitor	Fallback Behavior
X3 with new labels activated	Host monitor supports new labels	Labels in X3 are kept, even if the label set in the host monitor is set to Restricted .
X3 with new labels activated	Host monitor does not support new labels	<ul style="list-style-type: none"> • X3 does not enter companion mode. • X3 Unsupported INOP is issued on the host monitor. • Notification message "<i>Device on MSL with incompatible SW</i>" is displayed on the host monitor. • "<i>Deactivate <label> or change label to enter companion mode.</i>" is displayed on X3. • Once you have deactivated or changed all unsupported labels, it may take up to one minute until companion mode is established and all notification messages have been cleared.
X3 with new labels deactivated	Host monitor does not support new labels	X3 falls back to alternative label. See Configuration Guide for details.
MMX	Host monitor supports new labels	<ul style="list-style-type: none"> • Labels in the MMX are kept if the label set in the host monitor is set to Full • Labels in the MMX are not kept, if the label set in the host monitor is set to Restricted. The MMX falls back to an alternative label. See Configuration Guide for details.
MMX	Host monitor does not support new labels	MMX falls back to an alternative label. See Configuration Guide for details.

Additional Information - Accessories Chapter

WARNING

Defibrillation Protection: The defibrillation protection requires the use of the accessories specified in this section. Using other accessories may cause risk to patients, users or bystanders or may cause damage to the monitor.

Corrected Information - Invasive Pressure Accessories



These transducers and accessories are designed to have special protection against electric shocks (particularly regarding allowable leakage currents), and are defibrillator proof.

If you are using the M3012A Hemodynamic Measurement Extension, and you want to measure temperature and invasive pressure at the same time, we recommend that you use the pressure transducer CPJ840J6, with a round module connector piece, and not a transducer with a square connector. Pressure transducers with square connectors may make it difficult to connect the adjacent Temperature connector at the same time.

Contact ICU Medical for compatible disposable pressure transducers and accessories.

Pressure transducers and accessories	Part No.
Reusable pressure transducer 5 μ V/V/mmHg sensitivity	CPJ840J6
Sterile disposable pressure domes for CPJ840J6 (pack of 50)	CPJ84022
Transducer holder for CPJ840J6 (pack of 4)	CPJ84046
IV pole mount for CPJ840J6	CPJ84447
Monitoring Line Set for CPJ840J6	CPJ84026
Transpac IV dual IBP Cable	#K16 ¹
Dual IBP adapter	989803199741









¹ This cable is available from Philips only under option K16 of compatible monitors. Additional cables can be ordered from ICU Medical.

Pressure transducer kits	Part No.
PiCCO monitoring kit, 30 cm pressure line, includes PV4046 injectate temperature sensor housing for M1646A	PV8103
PiCCO monitoring kit, 150 cm pressure line, includes PV4046 injectate temperature sensor housing for M1646A	PV8115
PiCCO monitoring kit, 150 cm pressure line, includes PV4046 injectate temperature sensor housing for M1646A and central venous pressure line	PV8115CVP
PULSION Pressure Interface Cable for disposable pressure transducer	PMK 206

Additional Information - Specifications Chapter

Symbols

The following additional symbols can appear on the monitor and its associated equipment and packaging.

Symbols			
	CE mark accompanied by the Notified Body number 0123 (EU compulsory product compliance mark used for medical devices)		Indicates that the product was tested and has met the CSA certification requirements for Canada and the US
	Customs Union EAC Qualification Certification (Customs Union established by Russia, Belarus and Kazakhstan)		China RoHS mark
	RCM certification mark (Australian Communications Product Certification)		An information sign or warning sign that is part of the CE mark and is used to inform the user of the restrictions on the use of the device.
	CE Mark (EU compulsory product compliance mark)		Japan TELEC wireless certification mark
	Class II equipment		

ECG Alarm Specifications

ECG/Arrhythmia/ST/QT Alarm Specifications	Range	Adjustment
ST High	-19.8 to +20.0 mm	0.2 mm
ST Low	-20.0 to +19.8 mm	0.2 mm
STE Limit	-20.0 to +20.0 mm	0.2 mm

Philips FAST SpO2 Specifications

SpO ₂ Performance Specifications	
Numeric Update Rate	Typical: 2 seconds, Maximum: 30 seconds. Maximum with NBP Alarm Suppr. on: 60 seconds

NBP Specifications

NBP Performance Specifications	
STAT Mode Cycle Time	5 minutes plus time to complete the last measurement

Invasive Pressure Alarm Specifications

Invasive Pressure Alarm Specifications	Range	Adjustment	Delay
Extreme High	Difference to high limit 0 to 25 mmHg (0 to 3.5 kPa)	5 mmHg steps (0.5 kPa)	max. 12 seconds
	Clamping at -35 to 360 mmHg (-4.0 to 48.0 kPa)	5 mmHg steps (1.0 kPa)	
Extreme Low	Difference to low limit 0 to 25 mmHg (0 to 3.5 kPa)	5 mmHg steps (0.5 kPa)	
	Clamping at -40 to 355 mmHg (-5.0 to 47.0 kPa)	5 mmHg steps (1.0 kPa)	

CO₂ Specifications

Microstream CO ₂ Performance Specifications		
Total System Response Time		Less than the sum of the gas sampling delay time and rise time plus 1 second.

Mainstream CO ₂ Performance Specifications	
Rise Time	Less than 60 ms (with adult or infant reusable or disposable adapter)
Total System Response Time	Less than the rise time plus 1 second

Sidestream CO ₂ Performance Specifications	
Gas Sampling Delay Time	Less than 3 seconds
Rise Time	Less than 240 ms
Total System Response Time	Less than the sum of the gas sampling delay time and rise time plus 1 second

Masimo CO ₂ Performance Specifications	
Total System Response Time	Less than total system response time specified in the Instructions for Use provided by Masimo plus 1 second

NOTE

The following alarm specifications also apply to Masimo CO₂, which is available with MX500/MX550 and MX750/MX850 only:

CO ₂ Alarm Specifications	Range	Adjustment	Delay (excluding Total System Response Time)
etCO ₂ High	20 to 95 mmHg (2 to 13 kPa)	1 mmHg (0.1 kPa)	less than 14 seconds
etCO ₂ Low	10 to 90 mmHg (1 to 12 kPa)		
imCO ₂ High	2 to 20 mmHg (0.3 to 3.0 kPa)	steps of 1 mmHg (0.1 kPa)	less than 14 seconds
awRR High	Adult/pedi: 10 to 100 rpm Neo: 30 to 150 rpm	under 20 rpm: 1 rpm steps	less than 14 seconds
awRR Low	Adult/pedi: 0 to 95 rpm Neo: 0 to 145 rpm	over 20 rpm: 5 rpm steps	settings <20 rpm: less than 4 seconds settings >20 rpm: less than 14 seconds
IPI Low (Microstream CO ₂ only)	Adult/pedi: 2 to 9	steps of 1	Maximum 14 seconds after displayed value goes below the low alarm limit setting.
Apnea delay	10 to 40 seconds	5 second steps	set apnea delay time + 4 seconds

G7m Gas Analyzer Specifications

G7m Gas Analyzer Performance Specifications	
Total System Response Time	Less than the sum of the gas sampling delay time and rise time plus 1 second

•English	Addendum	3
•Français	Addenda	3
•Deutsch	Nachtrag	4
•Nederlands	Addendum	4
•Español	Anexo	5
•Português	Adendo	5
•Italiano	Addendum	6
•Norsk	Tillegg	6
•Svenska	Tillägg	7
•Suomi	Lisäys	7
•Dansk	Tillæg	7
•Magyar	Kiegészítés	8
•Polski	Dodatek	8
•Česky	Dodatek	9
•Slovenčina	Dodatok	9
•Slovenščina	Dodatek	10
•Srpski	Dopuna	10
•Română	Anexă	10
•Eesti	Lisa	11
•Latviešu	Pielikums	11
•Lietuvių k.	Priedas	11
•Български	Допълнение	12
•Русский	Дополнение	12
•Қазақша	Қосымша	13
•Українська	Додаток	13
•Ελληνικά	Συμπλήρωμα	14
•Türkçe	Ek	14
•Bahasa Indonesia	Adendum	14
•한국어	부록	15
•Tiếng Việt	Phụ lục	15
•日本語	補足	15
•繁體中文	附錄	16
•简体中文	附录	16





This addendum provides additional information for the IntelliVue MX100/X3, MX400-800 and MX750/MX850 Patient Monitor Instructions for Use. Please store it with your monitor documentation.

Introduction Chapter

Additional Information - Previous Generation Measurement Extensions Section

NOTE The M3015A Microstream CO₂ Measurement Extension with Hardware B (indicated by serial number prefix DE435; year of last manufacture: 2011) cannot be used with the IntelliVue X3 and MMX Multi-Measurement Modules. Using this Measurement Extension with an X3 or an MMX may cause the Multi-Measurement Module to lose its connection to the host monitor.

Cet addenda contient des informations complémentaires destinées au Manuel d'utilisation des moniteurs patient IntelliVue MX100/X3, MX400-800 et MX750/MX850. Veuillez le conserver avec la documentation de votre moniteur.

Chapitre Introduction

Informations complémentaires – Section Extensions de mesure ancienne génération

REMARQUE L'extension de mesure du CO₂ Microstream M3015A, modèle B (identifiée par le numéro de série, préfixe DE435 ; dernière année de fabrication : 2011) ne peut pas être utilisée avec les modules multi-mesure IntelliVue X3 et MMX. Son utilisation avec un X3 ou un MMX risque d'entraîner une perte de connexion entre le Module multi-mesure et le moniteur hôte.

Dieser Nachtrag enthält zusätzliche Informationen zur Gebrauchsanweisung der Patientenmonitore IntelliVue MX100/X3, MX400 bis 800 und MX750/MX850. Legen Sie ihn bitte mit der Monitorokumentation ab.

Kapitel „Einleitung“

Zusätzliche Informationen – Kapitel „Erweiterungen einer früheren Generation“

HINWEIS Die Microstream-CO₂-Erweiterung M3015A mit Hardware B (gekennzeichnet durch das Seriennummer-Präfix „DE435“; letztes Herstellungsjahr: 2011) kann nicht zusammen mit den Kombi-Modulen IntelliVue X3 und MMX eingesetzt werden. Bei Verwendung dieser Erweiterung mit einem X3 oder MMX kann es dazu kommen, dass die Verbindung zwischen Kombi-Modul und Host-Monitor unterbrochen wird.

In dit addendum vindt u aanvullende informatie voor de Gebruiksaanwijzing van de IntelliVue MX100/X3-, MX400-800- en MX750/MX850-patiëntmonitor. Bewaar dit addendum bij de documentatie van uw monitor.

Inleiding

Aanvullende informatie - Gedeelte Meetuitbreidingen van een eerdere generatie

OPMERKING De M3015A Microstream CO₂-meetuitbreiding met hardware B (aangeduid door serienummervoorvoegsel DE435; jaar van laatste fabricage: 2011) kan niet worden gebruikt met de IntelliVue X3- en MMX-Multi-Measurement Modules. Het gebruik van deze meetuitbreiding met een X3 of een MMX kan ervoor zorgen dat de Multi-Measurement Module de verbinding met de hostmonitor verliest.

Este anexo proporciona información adicional a las Instrucciones de uso de los monitores de paciente IntelliVue MX100/X3, MX400-800 y MX750/MX850. Guárdelo junto con la documentación relativa al monitor.

Capítulo Introducción

Información adicional: sección Extensiones de mediciones de la generación anterior

NOTA La extensión de medición CO₂ Microstream M3015A con hardware B (indicado por el prefijo del número de serie DE435; año de última fabricación: 2011) no se puede utilizar con los módulos multiparamétricos IntelliVue X3 ni MMX. En caso de utilizar esta extensión de medición con un X3 o con un MMX, puede provocar la pérdida de conexión del módulo multiparamétrico con el monitor host.

Este adendo proporciona informações adicionais às Instruções de Uso dos Monitores de Pacientes IntelliVue MX100/X3, MX400-800 e MX750/MX850. Arqueve-o junto com a documentação do monitor.

Capítulo Introdução

Informações adicionais - Seção de extensões de medição da geração anterior

OBSERVAÇÃO A Extensão de medição M3015A Microstream CO₂ com Hardware B (indicado pelo número de série com prefixo DE435; ano da última fabricação: 2011) não pode ser usado com os Módulos de múltipla medição IntelliVue X3 e MMX. Usar esta Extensão de medição com um X3 ou um MMX pode fazer com que o Módulo de múltipla medição perca sua conexão do monitor anfitrião.

Il presente addendum rappresenta un'integrazione alle Istruzioni d'uso del monitor paziente IntelliVue MX100/X3, MX400-800 e MX750/MX850. Conservarlo insieme alla documentazione relativa al monitor.

Capitolo Introduzione

Informazioni aggiuntive - Sezione Moduli di Estensione di generazione precedente

NOTA Il Modulo di Estensione con CO₂ Microstream M3015A con Hardware B (identificato dal prefisso del numero di serie DE435; ultimo anno di fabbricazione: 2011) non può essere utilizzato con i Moduli Multiparametrici IntelliVue MMX e IntelliVue X3. L'utilizzo di questo Modulo di Estensione con X3 o MMX può causare l'interruzione del collegamento tra il Modulo Multiparametrico e il monitor host.

Dette tillegget inneholder tilleggsinformasjon til brukerhåndboken for pasientmonitoren IntelliVue MX100/X3, MX400-800 og MX750/MX850. Tillegget bør oppbevares sammen med annen dokumentasjon om IntelliVue TcG10.

Kapittelet Innledning

Tilleggsinformasjon – avsnitt angående forrige generasjons tilleggsmoduler

MERK M3015A Microstream CO₂-tilleggsmodul med maskinvare B (angitt med serienummerprefiks DE435; siste produksjonsår: 2011) kan ikke brukes sammen med MMS-modulene for IntelliVue X3 and MMX. Bruk av denne tilleggsmodulen med X3 eller MMX kan forårsake brudd på koblingen mellom MMX og vertsmonitoren.

Det här tillägget innehåller ytterligare information till bruksanvisningen för patientmonitorerna IntelliVue MX100/X3, MX400-800 och MX750/MX850. Förvara det tillsammans med övrig patientmonitordokumentation.

Kapitlet Inledning

Ytterligare information – Avsnittet om föregående generationens mätningssystem

OBS! Mätningssystemet M3015A Microstream CO₂ med programvara B (anges genom serienummerprefixet DE435, sista tillverkningsår: 2011) kan inte användas med multimätningssystemen IntelliVue X3 och MMX. Om den här mätningssystemet används med en X3 eller MMX kan multimätningssystemet förlora kontakten med värdmonitorn.

Tämä lisäys sisältää IntelliVue MX100/X3-, MX400-800- ja MX750/MX850 -potilasmonitorin käyttöoppaaseen liittyviä lisätietoja. Säilytä tämä lisäys yhdessä monitorin ohjeiden kanssa.

Luku Johdanto

Lisätietoja – Osio Edellisen sukupolven mittauslaajennukset

HUOMAUTUS Laitteistolla B varustettua M3015A Microstream CO₂ -mittauslaajennusta (sarjanumerossa etuliite DE435, viimeinen valmistusvuosi: 2011) ei voi käyttää IntelliVue X3- ja MMX-monimittausmoduulin kanssa. Jos tätä mittauslaajennusta käytetään X3- tai MMX-moduulin kanssa, monimittausmoduulin yhteys isäntämonitoriin saattaa katketa.

Dette tillæg indeholder yderligere oplysninger til brugerhåndbogen til IntelliVue MX100/X3, MX400-800 og MX750/MX850 patientmonitorerne. Opbevar venligst dette tillæg sammen med dokumentationen til monitoren.

Introduktionskapitel

Yderligere oplysninger - afsnittet Parameterudvidelser af den forrige generation

BEMÆRK M3015A Microstream CO₂-parameterudvidelsen med Hardware B (angivet ved serienummerpræfix DE435; sidste fremstillingsår: 2011) kan ikke anvendes sammen med IntelliVue X3- og MMX-multiparametermoduler. Brug af denne parameterudvidelse sammen med et X3 eller et MMX kan få multiparametermodulet til at tabe forbindelsen til værtsmonitoren.

Ez a kiegészítés további információt tartalmaz az IntelliVue MX100/X3, MX400-800 és MX750/MX850 betegmonitorok használati útmutatójával kapcsolatban. Kérjük, tárolja a monitorral kapcsolatos dokumentumok között.

Bevezetés fejezet

További információ – Az előző generációs MMS bővítményekre vonatkozó rész

MEGJEGYZÉS Az M3015A Microstream CO₂ MMS bővítmény „B” hardverváltozata (amit a gyártási szám „DE435” előtagja jelez; a gyártás utolsó éve: 2011) nem használható az IntelliVue X3 és MMX többparaméteres mérőmodulokkal. Az MMS modul X3 vagy MMX többparaméteres mérőmodullal való használata esetén az utóbbiak kapcsolata megszakadhat a gazdamonitorral.

Niniejszy dodatek zawiera informacje uzupełniające instrukcje obsługi monitorów pacjenta IntelliVue MX100/X3, MX400–800 oraz MX750/MX850. Dodatek należy przechowywać wraz z pozostałą dokumentacją monitorów.

Rozdział Wstęp

Część Informacje dodatkowe — moduły pomiarowe poprzedniej generacji

UWAGA Moduł do pomiaru CO₂ w technologii Microstream M3015A ze sprzętem w wersji B (wskazanym przez prefiks numeru seryjnego DE435; ostatni rok produkcji 2011) nie może być używany z modułami wieloparametrowymi IntelliVue X3 i MMX. Korzystanie z tego modułu pomiarowego z modulem wieloparametrowym X3 lub MMX może powodować utratę połączenia modułu wieloparametrowego z monitorem głównym.

Tento dodatek poskytuje dodatečné informace k návodu k obsluze patientského monitoru IntelliVue MX100/X3, MX400-800 a MX750/MX850. Uložte si jej společně s dokumentací k monitoru.

Úvodní kapitola

Další informace – část Rozšíření měření předchozí generace

POZNÁMKA Rozšíření měření M3015A Microstream CO₂ s hardwarem B (označeno předponou výrobního čísla DE435, poslední výroba roku 2011) nelze používat s víceúčelovými měřicími moduly IntelliVue X3 a MMX. Použití tohoto rozšíření měření s modulem X3 nebo MMX může způsobit, že víceúčelý měřicí modul ztratí spojení s hostitelským monitorem.

Tento dodatok obsahuje dodatočné informácie k návodu na použitie patientskeho monitora IntelliVue MX100/X3, MX400-800 a MX750/MX850. Uložte ho k dokumentácii k monitoru.

Úvodná kapitola

Dodatočné informácie – Časť o rozšíreniach meraní predchádzajúcej generácie

POZNÁMKA Rozšírenie meraní M3015A Microstream CO₂ s hardvérom B (označené predponou sériového čísla DE435; rok poslednej výroby: 2011) nie je možné používať s viacúčelovými meracími modulmi IntelliVue X3 a MMX. Používanie tohto rozšírenia meraní so zariadením X3 alebo MMX môže spôsobiť, že viacúčelový merací modul stratí pripojenie k hostiteľskému monitoru.

Ta dodatek vsebuje dodatne informacije k navodilom za uporabo bolniškega monitorja IntelliVue MX100/X3, MX400-800 in MX750/MX850. Shranite ga skupaj z dokumentacijo monitorja.

Poglavje Uvod

Dodatne informacije – poglavje Razširitve meritev prejšnje generacije

OPOMBA Razširitev meritev M3015A Microstream CO₂ s strojno opremo različice B (označeno s predpono serijske številke DE435; leto zadnje izdelave: 2011) ni mogoče uporabljati z večparametričnimi moduli IntelliVue X3 in MMX. Uporaba razširitev meritev z modulom X3 ali MMX lahko povzroči, da večparametrični modul izgubi povezavo z gostiteljskim monitorjem.

Ova dopuna pruža dodatne informacije za uputstvo za upotrebu za IntelliVue MX100/X3, MX400-800 i MX750/MX850 uređaj za nadzor pacijenta. Čuvajte je sa dokumentacijom uređaja IntelliVue TcG10.

Uvodno poglavje

Dodatne informacije – Odeljak o produžecima za merenje prethodne generacije

NAPOMENA Produžetak za merenje CO₂ M3015A Microstream sa Hardware B (označen prefiksom serijskog broja DE435; poslednja godina proizvodnje: 2011.) ne može da se koristi sa modulima za više merenja IntelliVue X3 i MMX. Korišćenje ovog produžetka za merenje sa modulom X3 ili MMX može da uzrokuje gubitak veze između modula za više merenja i matičnog monitora.

Această anexă oferă informații suplimentare pentru instrucțiunile de utilizare a monitoarelor de pacient IntelliVue MX100/X3, MX400-800 și MX750/MX850. Vă rugăm să o păstrați împreună cu documentația monitorului dvs.

Capitolul Introducere

Informații suplimentare - Secțiunea extensiilor de măsurători din generațiile anterioare

NOTĂ Extensia de măsurători M3015A Microstream CO₂ cu hardware B (indicat de prefixul numărului de serie DE435; anul ultimei fabricări: 2011) nu poate fi utilizată cu modulele multi-măsurători IntelliVue X3 și MMX. Utilizarea acestei extensii de măsurători cu un dispozitiv X3 sau MMX poate cauza pierderea conexiunii modului de multi-măsurători la monitorul gazdă.

See lisa annab lisateavet patsiendimonitoride IntelliVue MX100/X3, MX400–800 ja MX750/MX850 kasutusjuhendile. Palun säilitage see koos oma monitori dokumentatsiooniga.

Sissejuhatav peatükk

Lisateave – eelmise põlvkonna mõõtmislaienduste jaotis

MÄRKUS Microstream CO₂ mõõtmislaiendust riistvara versiooniga B (seda tähistab seerianumbri eesliide DE435; viimati toodetud: 2011) ei saa kasutada mitmik-mõõtemoodulitega IntelliVue X3 ja MMX. Selle mõõtmislaienduse kasutamine mooduliga X3 või MMX võib põhjustada mitmik-mõõtemooduli ühenduse katkemist hostmonitoriga.

Šajā pielikumā sniegta papildinformācija IntelliVue MX100/X3, MX400-800 un MX750/MX850 pacienta monitora lietošanas instrukcijai. Lūdzu, glabājiet to kopā ar pārējo monitora dokumentāciju.

Ievada nodaļa

Papildinformācija — sadaļa Iepriekšējās paaudzes mērījumu pagarinājumi

PIEZĪME M3015A Microstream CO₂ mērījumu pagarinājums ar aparāturu B (norāda sērijas numura prefikss DE435; pēdējā ražojuma gads: 2011. gads) nav izmantojams ar IntelliVue X3 un MMX vairāku mērījumu moduļiem. Izmantojot šo mērījuma pagarinājumu kopā ar X3 vai MMX, var rasties vairāku mērījumu moduļa savienojuma atbrīvošanās pie saimniekdatora monitora.

Šiame priede pateikiama informacija papildu „IntelliVue“ MX100 / X3, MX400-800 ir MX750 / MX850 pacientų monitorių naudojimo instrukcijas. Laikykite priedą kartu su kitais monitoriaus dokumentais.

Ivado skyrius

Papildoma informacija – ankstesnēs kartos papildomųjų matavimo prietaisų skyrius

PASTABA „M3015A Microstream CO₂“ papildomojo matavimo prietaiso su B aparātūra (tai nurodo serijos numerio priešdēlis DE435; paskutiniai pagaminimo metai: 2011 m.) negalima naudoti su „IntelliVue X3“ ir MMX daugybinių matavimų moduļiais. Naudojant šį papildomąjį matavimo prietaisą su X3 arba MMX, daugybinių matavimų modulis gali prarasti ryšį su pagrindinio kompiuterio monitoriumi.

Това допълнение осигурява допълнителна информация за указанията за употреба на пациентен монитор IntelliVue MX100/X3, MX400-800 и MX750/MX850. Съхранявайте го с документацията за вашия монитор.

Глава Въведение

Допълнителна информация – раздел „Измервателни приставки от предишно поколение“

ЗАБЕЛЕЖКА Измервателната приставка M3015A за CO₂ с Microstream с хардуер В (указано чрез представката на серийен номер DE435; година на последно производство: 2011 г.) не може да се използва с IntelliVue X3 и мултиизмервателните модули ММХ. Използването на измервателната приставка с X3 или ММХ може да предизвика загуба на връзка на мултиизмервателния модул с хост монитора.

В настоящем дополнении представлены сведения, дополняющие инструкции по эксплуатации мониторов пациента IntelliVue MX100/X3, MX400-800 и MX750/MX850. Храните его вместе с документацией на монитор.

Глава «Введение»

Дополнительные сведения: раздел «Модули расширения предыдущего поколения»

ПРИМЕЧАНИЕ Модуль расширения Microstream CO₂ (M3015A) с аппаратным обеспечением версии В (определяется по серийному номеру, начинающемуся с DE435; год вывода из производства: 2011) нельзя использовать вместе с многопараметрическими измерительными модулями IntelliVue X3 и ММХ. Использование данного модуля расширения с X3 или ММХ может привести к потере соединения между многопараметрическим измерительным модулем и основным монитором.

Осы қосымшада IntelliVue MX100/X3, MX400-800 және MX750/MX850 емделуші мониторының Пайдалану нұсқаулығына қосымша ақпарат беріледі. Оны монитордың құжаттамасымен бірге сақтаңыз.

«Кіріспе» тарауы

Қосымша ақпарат - Алдыңғы буын өлшем кеңейтімдері бөлімі

ЕСКЕРТПЕ В жабдығы (DE435 сериялық нөмір префиксімен көрсетіледі; соңғы өндірілген жылы: 2011) бар M3015A Microstream CO₂ өлшем кеңейтімін IntelliVue X3 және MMX көппараметрлі өлшем модульдерімен пайдалануға болмайды. Бұл өлшем кеңейтімін X3 немесе MMX модулімен пайдалану салдарынан Көппараметрлі өлшем модулі мен негізгі монитор арасында байланыс жоғалуы мүмкін.

У цьому документі міститься додаткова інформація щодо Інструкцій із використання монітора пацієнта IntelliVue MX100/X3, MX400-800 і MX750/MX850. Зберігайте його з документацією вашого монітора.

Глава «Вступ»

Додаткова інформація: розширення багатопараметричного вимірювального модуля попереднього покоління

ПРИМІТКА Розширення багатопараметричного вимірювального модуля M3015A для Microstream CO₂ з обладнанням В (з префіксом DE435 у серійному номері; рік останнього виробництва: 2011) не можна використовувати з модулями IntelliVue X3 та MMX. Таке використання може призвести до втрати зв'язку між модулями X3 або MMX і головним монітором.

Το παρόν συμπλήρωμα παρέχει πρόσθετες πληροφορίες σχετικά με τις Οδηγίες χρήσης των μόνιτορ ασθενούς IntelliVue MX100/X3, MX400-800 και MX750/MX850. Φυλάξτε το μαζί με το υλικό τεκμηρίωσης του μόνιτορ.

Κεφάλαιο "Εισαγωγή"

Πρόσθετες πληροφορίες - Ενότητα "Επεκτάσεις μετρήσεων προηγούμενης γενιάς"

ΣΗΜΕΙΩΣΗ Η επέκταση μέτρησης Microstream CO₂ M3015A με Υλικό (Hardware) B (δηλώνεται από το πρόθημα σειριακού αριθμού DE435, έτος τελευταίας κατασκευής: 2011) δεν μπορεί να χρησιμοποιηθεί με τις μονάδες πολλαπλών μετρήσεων IntelliVue X3 και MMX. Η χρήση της συγκεκριμένης επέκτασης μετρήσεων με X3 ή MMX μπορεί να προκαλέσει την απώλεια της σύνδεσης της μονάδας πολλαπλών μετρήσεων με το κεντρικό μόνιτορ.

Bu ek, IntelliVue MX100/X3, MX400-800 ve MX750/MX850 Hasta Monitörü Kullanım Talimatları'na ek bilgi sağlar. Lütfen bu eki monitörünüzün belgeleriyle birlikte saklayın.

Giriş Bölümü

Ek Bilgi - Önceki Nesil Ölçüm Uzantıları Kısmı

NOT B Donanımlı M3015A Microstream CO₂ Ölçüm Uzantısı (DE435 seri numarası ön eki ile belirtilir; son üretim yılı: 2011) IntelliVue X3 ve MMX Çoklu Ölçüm Modülleri ile kullanılamaz. Bu Ölçüm Uzantısının X3 veya MMX ile kullanılması, Çoklu Ölçüm Modülü ile ana monitör arasındaki bağlantının kopmasına neden olabilir.

Tambahan ini berisi informasi tambahan untuk Petunjuk Penggunaan Monitor Pasien IntelliVue MX100/X3, MX400-800 dan MX750/MX850. Simpanlah bersama dokumentasi monitor Anda.

Bab Pendahuluan

Informasi Tambahan - Bagian Ekstensi Pengukuran Generasi Sebelumnya

CATATAN Ekstensi Pengukuran CO₂ Microstream M3015A dengan Perangkat Keras B (ditunjukkan oleh nomor seri berawalan DE435; tahun produksi terakhir: 2011) tidak bisa digunakan dengan IntelliVue X3 dan Modul Multipengukuran MMX. Jika Ekstensi Pengukuran ini digunakan dengan X3 atau MMX, maka dapat mengakibatkan hilangnya koneksi Modul Multipengukuran dengan monitor host.

이 부록은 IntelliVue MX100/X3, MX400-800 및 MX750/MX850 Patient Monitor 사용 설명서에 추가되는 정보를 제공합니다. IntelliVue TcG10 관련 문서와 함께 보관하십시오.

'소개' 장

추가 정보 - 이전 세대 Measurement Extension 모듈 섹션

참고 하드웨어 B와 결합된 M3015A Microstream CO₂ Measurement Extension 모듈(일련 번호 앞자리 DE435로 표시; 마지막 제조 연도: 2011)은 IntelliVue X3 및 MMX Multi-Measurement 모듈과 함께 사용할 수 없습니다. 이 Measurement Extension을 X3 또는 MMX에 사용하면 Multi-Measurement 모듈과 호스트 모니터 사이의 연결이 끊길 수 있습니다.

Tiếng Việt

Phụ lục

Phụ lục này cung cấp thông tin bổ sung cho Hướng Dẫn Sử Dụng Máy Theo Dõi Bệnh Nhân IntelliVue MX100/X3, MX400-800 và MX750/MX850. Vui lòng cất giữ phụ lục này cùng với tài liệu hướng dẫn máy theo dõi của bạn.

Chương Giới thiệu

Mục Thông tin bổ sung - Phần mở rộng đo thể hệ trước

LƯU Ý Không thể sử dụng M3015A Microstream CO₂ Measurement Extension có Phần cứng B (được chỉ báo bằng tiền tố số sê-ri DE435; năm sản xuất gần nhất: 2011) chung với IntelliVue X3 và MMX Multi-Measurement Module. Việc sử dụng Measurement Extension này chung với X3 hoặc MMX có thể làm cho Multi-Measurement Module mất kết nối với máy theo dõi chính.

日本語

補足

本書は、IntelliVue MX100/X3、MX400～800、およびMX750/MX850 生体情報モニタのユーザーズガイドの内容を補足するものです。本書はお使いのモニタの付属文書と併せて保管してください。

「概要」の章

補足情報 - 「旧世代の拡張モジュール」の項

注記 M3015A Microstream CO₂ 拡張モジュールのうちハードウェア B搭載製品(シリアル番号が DE435 で始まるもの、最終製造年は 2011 年)は、IntelliVue X3 および MMX マルチメジャメントモジュールと併用できません。該当の拡張モジュールを X3 または MMX と併用すると、マルチメジャメントモジュール(X3 または MMX) とホストモニタ間の接続が失われるおそれがあります。

本附錄提供《IntelliVue MX100/X3、MX400-800 和 MX750/MX850 病患監視器使用說明》的補充資訊。本附錄請與監視器說明文件一同保存。

簡介章節

補充資訊 - 上一代測量擴充模組一節

注意 配備硬體 B 的 M3015A Microstream CO₂ 測量擴充模組 (序號首碼 DE435；最後製造年分：2011 年) 無法搭配 IntelliVue X3 及 MMX 多功能測量模組使用。將此測量擴充模組搭配 X3 或 MMX 使用，可能會使多功能測量模組失去與主監視器的連線。

本附录提供的是 IntelliVue MX100/X3、MX400-800 和 MX750/MX850 病人监护仪使用说明书的附加信息。请与您的监护仪文档一同保存。

简介章节

附加信息 - 上一代测量扩展件/模块部分

注意 M3015A Microstream CO₂ 测量扩展件/模块硬件版本 B (由序列号前缀 DE435 表示；最后生产年份：2011) 不可配合 IntelliVue X3 及 MMX 多测量模块使用。若配合 X3 或 MMX 使用，会导致多测量模块丢失与主监护仪的连接。