

Impella RP[®] System

with the Automated Impella Controller

Circulatory Support System

INSTRUCTIONS FOR USE & CLINICAL REFERENCE MANUAL

(United States only)

IMPORTANT NOTICE: Read this entire manual before using the Automated Impella Controller and Impella RP Circulatory Support System (Impella RP System). The Impella RP System is to be used only in accordance with this manual. This manual is only applicable to Impella systems using the Automated Impella Controller.

Information contained in this document is subject to change without notice.

©2020 Abiomed[®], Inc. All rights reserved.

The ABIOMED logo, ABIOMED, Impella, Impella 2.5, Impella CP, Impella CP with SmartAssist, Impella 5.0, Impella 5.5 with SmartAssist, Impella LD, Impella RP, Impella Connect and Recovering Hearts. Saving Lives. are registered trademarks of ABIOMED, Inc. in the U.S. and in certain foreign countries.

The following information pertains to the Emergency Use Authorization (EUA) during the COVID-19 outbreak granted by the FDA and does not apply to the indications approved under the PMA (i.e., providing temporary right ventricular support for up to 14 days in patients with a body surface area $> 1.5 \text{ m}^2$, who develop acute right heart failure or decompensation following left ventricular assist device implantation, myocardial infarction, heart transplant, open-heart surgery):

- The Impella RP has neither been cleared or approved for use by healthcare providers (HCP) in the hospital setting for providing temporary right ventricular support for up to 14 days in critical care patients with a body surface area $\geq 1.5 \text{ m}^2$, for the treatment of acute right heart failure or decompensation caused by complications related to Coronavirus Disease 2019 (COVID-19), including pulmonary embolism (PE);
- The Impella RP has been authorized for the above emergency use by FDA under an EUA; and,
- The Impella RP has been authorized only for the duration of the declaration that circumstances exist justifying the authorization of the emergency use of medical devices under section 564(b)(1) of the Act, 21 U.S.C. § 360bbb-3(b)(1), unless the authorization is terminated or revoked sooner.

IMPELLA RP® SYSTEM WITH THE AUTOMATED IMPELLA CONTROLLER™ INSTRUCTIONS FOR USE & CLINICAL REFERENCE MANUAL

(UNITED STATES ONLY)

Rx Only

Abiomed, Inc.

22 Cherry Hill Drive
Danvers, MA 01923
978-777-5410 (voice)
978-777-8411 (fax)
clinical@abiomed.com (email)

Abiomed Europe GmbH

Neuenhofer Weg 3
52074 Aachen, Germany
+49 (0) 241 8860-0 (voice)
+49 (0) 241 8860-111 (fax)
europe@abiomed.com (email)

www.abiomed.com

24-Hour Emergency Hotlines:

N. America 1-800-422-8666
Europe +49 (0) 1805 2246633

April 2020

Document No. 0046-9062 Rev. E

TABLE OF CONTENTS

Introduction	I	AUTOMATED IMPELLA CONTROLLER ALARMS	
1 INDICATIONS, CONTRAINDICATIONS, AND POTENTIAL ADVERSE EVENTS		Alarms Overview	7.1
Indications (United States).....	1.1	Alarm Message Summary.....	7.3
Contraindications (United States).....	1.1	8 GENERAL SYSTEM INFORMATION	
Potential Adverse Events (United States).....	1.1	Terminology, Abbreviations, and Symbols.....	8.1
2 WARNINGS AND CAUTIONS		Automated Impella Controller Mechanical Specifications	8.3
Warnings	2.1	Automated Impella Controller Electrical Specifications	8.3
Cautions.....	2.3	Equipment Design	8.4
3 THE IMPELLA RP® SYSTEM CATHETER AND AUTOMATED IMPELLA CONTROLLER		Equipment Classifications	8.4
Overview.....	3.1	Federal Communications Commission (FCC) Notice	8.5
Impella RP® System Catheter.....	3.3	Electromagnetic Compatibility	8.5
Automated Impella Controller	3.5	Transport Between Hospitals	8.11
Purge Cassette.....	3.6	Transport Within the Hospital	8.12
Accessories	3.8	VGA Monitor Connection	8.13
4 USING THE AUTOMATED IMPELLA CONTROLLER		Alarm Delay Information	8.13
Overview.....	4.1	Patient Environment	8.14
Automated Impella Controller Features	4.1	Use Environment	8.14
Automated Impella Controller Display.....	4.5	White Connector Cable	8.14
Placement Screen	4.8	Impella RP System Catheter Parameters	8.15
Purge Screen.....	4.9	Cleaning	8.16
Infusion History	4.10	Storing the Automated Impella Controller	8.16
Mobile Operation	4.11	Returning an Impella RP System Catheter to Abiomed (United States)	8.16
5 USING THE AUTOMATED IMPELLA CONTROLLER WITH THE IMPELLA RP® SYSTEM CATHETER		APPENDICES	
Impella RP Patient Selection	5.1	Appendix A: Automated Impella Controller Menu Structure	A.1
Anti-Coagulation Therapy with Impella Heparin Infusion	5.4		
Startup.....	5.7		
Case Start.....	5.10		
Inserting the Impella RP System Catheter.....	5.16		
Positioning and Starting the Impella RP System Catheter	5.18		
Use of the Repositioning Sheath and the 23 Fr Peel-away Introducer ..	5.19		
P-Levels.....	5.20		
Suction.....	5.20		
Purge Cassette Procedures	5.21		
Troubleshooting the Purge System.....	5.24		
Patient Weaning	5.25		
Removing the Impella RP® System Catheter.....	5.26		
6 CLINICAL EXPERIENCE			
Summary of Primary Clinical Study	6.1		
Study Designs.....	6.1		
Impella RP System Post Approval Study (PAS).....	6.3		
Accountability of Cohort.....	6.4		
Safety and Effectiveness Results	6.9		
Other Results	6.12		

TABLE OF CONTENTS

FIGURES

Figure 3.1 Impella RP® System Catheter in the Heart	3.1
Figure 3.2 Automated Impella Controller, Impella RP System Catheter, and Accessories.....	3.2
Figure 3.3 Impella RP System Catheter.....	3.3
Figure 3.4 Automated Impella Controller – Front View	3.5
Figure 3.5 Purge Cassette.....	3.6
Figure 3.6 White Connector Cable.....	3.8
Figure 3.7 Introducer Kit	3.8
Figure 3.8 Placement Guidewire	3.8
Figure 3.9 Dextrose Solution.....	3.9
Figure 3.10 Automated Impella Controller Cart	3.9
Figure 4.1 Automated Impella Controller Features – Front View	4.1
Figure 4.2 Automated Impella Controller Features – Side Views.....	4.3
Figure 4.3 Automated Impella Controller Display Elements - Screen View ...	4.5
Figure 4.4 Placement Screen.....	4.8
Figure 4.5 Purge Screen.....	4.9
Figure 4.6 Infusion History Screen	4.11
Figure 5.1 Best Practices - Patient Selection Guidance with Right Ventricular Failure - Impella RP Heart Pump	5.1
Figure 5.2 Impella RP Best Practice Selection Algorithm	5.2
Figure 5.3 Automated Impella Controller Power Switch	5.8
Figure 5.4 Automated Impella Controller Startup Screen	5.9
Figure 5.5 Initial Case Start Screen	5.10
Figure 5.6 Inserting the Purge Cassette into the Automated Impella Controller	5.11
Figure 5.7 Inserting the Catheter Plug into the Connector Cable	5.12
Figure 5.8 Snapping Purge Clip to Connector Cable	5.12
Figure 5.9 Connecting the Luer to the Impella RP System Catheter.....	5.13
Figure 5.10 Priming the Purge	5.13
Figure 5.11 Entering Purge Fluid Information.....	5.14
Figure 5.12 Changing Purge Fluid Information.....	5.15
Figure 5.13 Connecting the Purge Tubing to the Connector Cable	5.15
Figure 5.14 Impella RP System Configuration	5.16
Figure 5.15 Maximum Performance Level	5.18
Figure 5.16 Disconnecting the Y Connector from the Purge Cassette Tubing.....	5.21
Figure 5.17 Air Detected Alert.....	5.23
Figure 6.1 StudyFlow Schematic	6.4
Figure 6.2 Central Venous Pressure Change Over Time.....	6.10
Figure 6.3 Cardiac Index Change Over Time	6.10
Figure 6.4 LVAD Flow Change from Baseline to On support	6.11
Figure 6.5 Inotrope and Pressor Uses during Support	6.11
Figure 7.1 Alarm Window	7.2
Figure 8.1 Automated Impella Controller Patient Environment	8.14

TABLES

Table 3.1 Impella RP System Catheter Components.....	3.3
Table 3.2 Purge Cassette Components	3.7
Table 3.3 Impella RP System Catheter and Automated Impella Controller Accessories.....	3.8
Table 4.1 Automated Impella Controller Front View Features.....	4.2
Table 4.2 Automated Impella Controller Side View Features	4.4
Table 4.3 Automated Impella Controller Display Elements.....	4.5
Table 5.1 Exclusion Criteria for the Impella RP Pre-Market Clinical Study..	5.3
Table 5.2 Clinical scenarios for anti-coagulation therapy with the Impella purge system heparin (50 U/mL)	5.5
Table 5.3 Patient scenarios for anti-coagulation therapy with the Impella purge system heparin (25 U/mL)	5.6
Table 5.4 P-Level Flow Rates	5.20
Table 6.1 Patient Characteristics	6.6
Table 6.2 Baseline Laboratory Parameters	6.7
Table 6.3 Baseline Support and Hemodynamic Characteristics	6.8
Table 6.4 Patient Survival Outcomes	6.9
Table 6.5 Secondary Safety Endpoints Results.....	6.9
Table 6.6 Procedural Parameters	6.12
Table 7.1 Alarm Levels	7.1
Table 7.2 Automated Impella Controller Alarm Messages.....	7.3
Table 8.1 Terminology and Abbreviations	8.1
Table 8.2 Symbols	8.1
Table 8.3 Mechanical specifications for the Automated Impella Controller..	8.3
Table 8.4 Electrical specifications for the Automated Impella Controller ...	8.3
Table 8.5 Equipment Classifications	8.4
Table 8.6 Guidance and Manufacturer’s Declaration - Emissions, All Equipment and Systems	8.6
Table 8.7 Guidance and Manufacturer’s Declaration - Immunity.....	8.7
Table 8.8 Guidance and Manufacturer’s Declaration - Emissions, Equipment and Systems that are Life-supporting.....	8.8
Table 8.8 Guidance and Manufacturer’s Declaration - Emissions, Equipment and Systems that are Life-supporting.....	8.9
Table 8.9 Recommended separation distances between portable and mobile RF communications equipment and the Automated Impella Controller, equipment and systems that are life-supporting	8.9
Table 8.10 RFID Transmitter / Receiver Specifications.....	8.10
Table 8.11 Impella Connect Wi-Fi transmitter / Receiver Specifications...	8.10
Table 8.12 Alarm Delay Information	8.13
Table 8.13 Impella Catheter Parameters.....	8.15

INTRODUCTION

PURPOSE OF MANUAL

This Instructions for Use & Clinical Reference Manual is designed for healthcare professionals. It contains clinical and technical information to guide healthcare professionals in their use of the Impella RP® System Catheter with the Automated Impella Controller. To use the system you must understand and follow these instructions. The Impella RP System may be used only for its intended purpose.

MANUAL OVERVIEW

This manual provides instructions for use of the Impella RP System Catheter with the Automated Impella Controller. The following summarizes the contents of each section of the manual.

- **Section 1: Indications, Contraindications, and Potential Adverse Events** discusses indications for use of the Impella RP System Catheter with the Automated Impella Controller, contraindications, and potential adverse events that may be associated with the use of the system.
- **Section 2: Warnings and Cautions** discusses the warnings and cautions pertaining to the use of the Impella RP System Catheter with the Automated Impella Controller.
- **Section 3: The Impella RP System Catheter and Automated Impella Controller** provides an overview of the system and describes its major components and features.
- **Section 4: Using the Automated Impella Controller** describes the controls and various screen types on the Automated Impella Controller.
- **Section 5: Using the Automated Impella Controller with the Impella RP System Catheter** provides the procedures for using the Impella RP System.
- **Section 6: Clinical Experience** provides an overview of the RECOVERRIGHT trial, which studied the use of the Impella RP System in a U.S. clinical trial. The results of this trial were reviewed by the FDA prior to its approval of the Impella RP System.
- **Section 7: Automated Impella Controller Alarms** provides a listing of Automated Impella Controller alarms as well as information on what to do to resolve them.
- **Section 8: General System Information** contains information including definitions for key terms that appear in the manual, descriptions of the abbreviations and symbols that appear on Impella RP System Catheter and Automated Impella Controller components and packaging, technical information pertaining to the Impella RP System Catheter and Automated Impella Controller, and instructions on cleaning and storing system components as well as returning components to Abiomed.
- **Appendices** at the end of the manual provide supplemental information about topics including the Automated Impella Controller menu structure.

1 INDICATIONS, CONTRAINDICATIONS, AND POTENTIAL ADVERSE EVENTS



INDICATIONS (UNITED STATES) 1.1
CONTRAINDICATIONS (UNITED STATES) 1.1
POTENTIAL ADVERSE EVENTS (UNITED STATES) 1.2

INDICATIONS (UNITED STATES)

PMA approved indication:

The Impella RP System is indicated for providing temporary right ventricular support for up to 14 days in patients with a body surface area $\geq 1.5 \text{ m}^2$, who develop acute right heart failure or decompensation following left ventricular assist device implantation, myocardial infarction, heart transplant, or open-heart surgery.

Emergency Use Authorization:

The Impella RP System is authorized to be used by healthcare providers (HCP) in the hospital setting for providing temporary right ventricular support for up to 14 days in critical care patients with a body surface area $\geq 1.5 \text{ m}^2$, for the treatment of acute right heart failure or decompensation caused by complications related to Coronavirus Disease 2019 (COVID-19), including pulmonary embolism (PE).

CONTRAINDICATIONS (UNITED STATES)

The Impella RP System is contraindicated for use with patients experiencing any of the following conditions: Disorders of the pulmonary artery wall that would preclude placement or correct positioning of the Impella RP device; Mechanical valves, severe valvular stenosis or valvular regurgitation of the tricuspid or pulmonary valve; Mural thrombus of the right atrium or vena cava; Anatomic conditions precluding insertion of the pump; Presence of a vena cava filter or caval interruption device, unless there is clear access from the femoral vein to the right atrium that is large enough to accommodate a 22 Fr catheter.

POTENTIAL ADVERSE EVENTS (UNITED STATES)

Arrhythmia, Atrial fibrillation, Bleeding, Cardiac tamponade, Cardiogenic shock, Death, Device Malfunction, Hemolysis, Hepatic failure, Insertion site infection, Perforation, Phlegmasia cerulea dolens (a severe form of deep venous thrombosis), Pulmonary valve insufficiency, Respiratory dysfunction, Sepsis, Thrombocytopenia, Thrombotic vascular (non-central nervous system complication), Tricuspid valve injury, Vascular injury, Venous thrombosis, Ventricular fibrillation and/or tachycardia.

In addition to the risks above, there are other WARNINGS and PRECAUTIONS associated with Impella RP System.

Visit www.abiomed.com/impella/impella-rp to learn more.

2 WARNINGS AND CAUTIONS



WARNINGS..... 2.1
CAUTIONS 2.3

WARNINGS



The Impella RP System is intended for use only by personnel trained in accordance with the Abiomed Training Program.



Fluoroscopy is required to guide placement of the Impella RP System Catheter. The small placement guidewire must be reliably observed at all times.



Be sure that the stopcock on the repositioning sheath is always kept in the closed position. Significant bleed back can result if the stopcock is open.



Avoid manual compression of the inlet, outlet, or sensor areas of the cannula assembly.



The sterile components of the Impella RP System can be used only if the sterilization indicators show that the contents have been sterilized, the packaging is not damaged, and the expiration date has not elapsed.



Do **NOT** resterilize or reuse the Impella RP System Catheter. It is a disposable device and is intended for single use only. Reuse, reprocessing, reinserting through the introducer, or resterilization may compromise the structural integrity of the catheter and/or lead to catheter failure which, in turn, may result in patient injury, illness, or death.



Retrograde flow will occur from the pulmonary artery back into the inferior vena cava if the Impella RP System Catheter is set at performance level P0.



Do **NOT** use saline in the purge system.



Do **NOT** use an Impella RP System if any part of the system is damaged.



To prevent the risk of explosion, do **NOT** operate the Impella RP System near flammable anesthetics.



If at any time during the course of support with the Impella RP System Catheter, the Automated Impella Controller alarms "Purge Pressure Low" or "Purge System Open," follow the instructions presented in section 5 of this manual.



MR Unsafe - Do **NOT** subject a patient who has been implanted with an Impella RP System Catheter to magnetic resonance imaging (MRI). The strong magnetic energy produced by an MRI machine may cause the Impella RP System components to stop working, and result in injuries to the patient. An MRI may also damage the Impella RP System electronics.



Cardiopulmonary support (CPR) should be initiated immediately per hospital protocol if indicated for any patient supported with the Impella RP System Catheter. When initiating CPR, reduce the Impella RP System Catheter flow rate. When cardiac function has been restored, return flow rate to the previous level and assess the placement signal on the controller.



During defibrillation, do **NOT** touch the Impella RP System Catheter, cables, or Automated Impella Controller.

Warnings

Warnings alert you to situations that can cause death or serious injury. The red symbol appears before warning messages.



Power the Automated Impella Controller using its internal battery if the integrity of the protective earth conductor is questionable.



Medical electrical equipment needs special precautions regarding EMC and needs to be installed and put into service according to the electromagnetic compatibility (EMC) information provided in section 8 of this manual.



The Automated Impella Controller (AIC) performs as intended when exposed to radiofrequency (RF) disturbances below 20V/m. During transport, the AIC may be exposed to RF disturbances above 20 V/m, which could cause minor problems, such as intermittent displays of soft button menu selections, which have no effect on the operating parameters of the Impella support system, and will resolve readily once the disturbance ends. It could also potentially result in loss of support. Patients must be closely monitored at all times during transport.



Portable and mobile RF communications equipment can affect medical electrical equipment.



The equipment or system should not be used adjacent to or stacked with other equipment. If adjacent or stacked use is necessary, the equipment or system should be observed to verify normal operation in the configuration in which it will be used.



Use of cables, other than those sold by Abiomed, may result in increased emissions or decreased immunity of the Automated Impella Controller.



The Automated Impella Controller uses RFID (radio frequency identification) to identify and communicate with the purge cassette. Other equipment may interfere with the Automated Impella Controller even if that other equipment complies with CISPR emission requirements.



Avoid overinserting the Impella RP System Catheter and possibly impinging the catheter tip against the walls of the vasculature, atrium, or ventricle.



Torquing the catheter should be monitored carefully using fluoroscopy.



Do **NOT** advance or withdraw the Impella RP System Catheter against resistance without using fluoroscopy to determine the cause of the resistance. Doing so could result in separation of the catheter or guidewire tip, damage to the catheter or vessel, or perforation.



Portable RF communications equipment (including peripherals such as antenna cables and external antennas) should be used no closer than 30 cm (12 inches) to any part of the Impella System, including cables specified by Abiomed. Otherwise, degradation of the performance of this equipment could result.



Do not transport an Impella patient via commercial aircraft. Loss of support may occur aboard a commercial aircraft due to exposure to radiofrequency (RF) disturbances above the compliance level (<20V/m) of the Automated Impella Controller.

CAUTIONS



Handle with care. The Impella RP System Catheter can be damaged during removal from packaging, preparation, insertion, and removal. Do **NOT** bend, pull, or place excess pressure on the catheter or mechanical components at any time.



Inspect the Impella RP System Set packaging while opening. In the event that any key components, including its end seal labels, are damaged excessively during shipment, the use of a back-up Impella RP System Set should be considered.



Patients with tricuspid or pulmonary valve stenosis or insufficiency, and patients with prosthetic tricuspid or pulmonary valves, may be compromised by the use of the Impella RP System Catheter.



Use only original accessories and replacement parts supplied by Abiomed.



Do **NOT** use damaged or contaminated connector cables.



To prevent device failure, do **NOT** start the Impella RP System Catheter until the placement guidewire has been removed.



Do **NOT** remove the Impella RP System Catheter over the length of the placement guidewire.



When replacing the purge cassette, the replacement process must be completed within 90 seconds of disconnecting luer. The Impella RP System Catheter may be damaged if replacement takes longer than 90 seconds.



To prevent malfunction of the Automated Impella Controller, avoid long-term exposure to direct sunlight and excessive heat (40°C).



To prevent overheating and improper operation, do **NOT** block the cooling vents of the Automated Impella Controller while it is operating.



Do **NOT** kink or clamp any part of the Impella RP System Catheter.



Do **NOT** use the Impella RP System Catheter with a damaged or kinked introducer. Replace the introducer if a kink is observed.



The Li-Ion batteries must be charged for 5 hours prior to system operation in order to meet the runtime requirement of 1 hour. Failure to do so will yield a shorter runtime. After being unplugged, the Automated Impella Controller will operate for at least 60 minutes after the batteries have been fully charged.



Minimize exposure of Impella RP System components to sources of electromagnetic interference (EMI). Exposure to sources of EMI, such as cell phones and two-way radios, may cause operational interference. To clear interference, either increase the distance between system components and the EMI source or turn off the EMI source.



Operation of Impella RP System components may interfere with the operation of other devices. If interference occurs, increase the distance between the device and system components.



Operation of the system without heparin in the purge solution has not been tested. In the event that a patient is intolerant to heparin, due to heparin-induced thrombocytopenia or bleeding, physicians should use their clinical judgment to assess the risks versus benefits of operating the Impella System without heparin. If it is in the best interest of the patient to operate the system without heparin, the dextrose solution is still required, and physicians should consider systemic delivery of an alternative anticoagulant. The Impella Catheter has not been tested with any alternative anticoagulants in the purge solution. Use of alternative anticoagulants may reduce the longevity or performance of the Impella catheter.



Have a backup Automated Impella Controller, purge cassette, connector cable, and Impella RP System Catheter available in the unlikely event of a device failure.



Do **NOT** use the bed mount as a handle.



Insertion through the left femoral vein may result in repeated attempts to properly position the Impella RP System, which could cause excessive manipulation and pump damage. As a result, left femoral insertion should be avoided whenever possible.



Do not insert any unauthorized devices into the USB port. This includes chargers, memory sticks, wireless dongles and other unauthorized devices.



During use with the Impella Connect, a Medical Device Data System (MDDS), if the Automated Impella Controller is exposed to strong electromagnetic disturbances, the Impella Connect may either restart or shut down. Operators should be aware that, under these conditions, the Automated Impella Controller operating parameters are not affected.



Keep patient cable away from power cables and other high voltage signal cables.



Impella is compatible with High Frequency surgical equipment. However, when using HF surgical equipment, the impella cannot come in contact with the surgical equipment.



Benefits of Impella RP in salvage patients have not been proven.

3 THE IMPELLA RP® SYSTEM CATHETER AND AUTOMATED IMPELLA CONTROLLER™



OVERVIEW	3.1
Reusable System Components	3.2
Single-use System Components	3.2
System Configuration	3.2
IMPELLA RP® SYSTEM CATHETER	3.3
Differential Pressure Sensor	3.4
AUTOMATED IMPELLA CONTROLLER	3.5
PURGE CASSETTE	3.6
ACCESSORIES.....	3.8

OVERVIEW

The Impella RP System Catheter is an intracardiac microaxial blood pump that supports a patient's pulmonary circulation. The Impella RP System Catheter is inserted percutaneously through the femoral vein and into the pulmonary artery (see Figure 3.1).

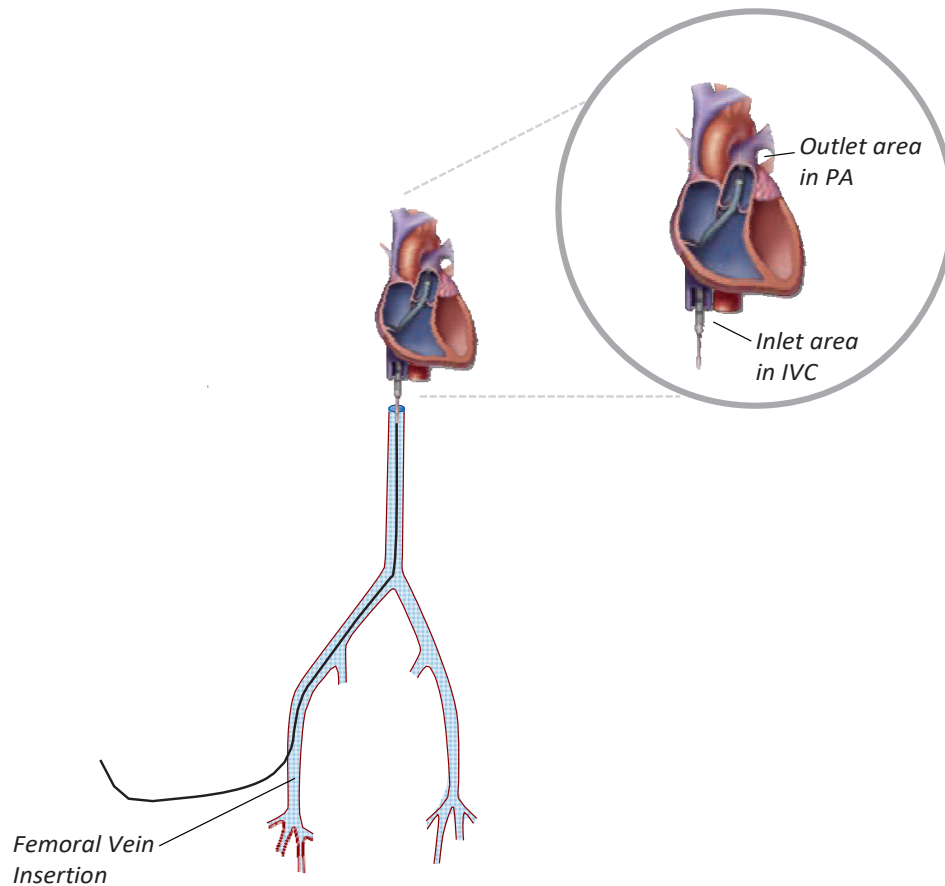

Figure 3.1 Impella RP® System Catheter in the Heart

When properly positioned, the Impella RP System Catheter delivers blood from the inlet area, which sits in the inferior vena cava, through the cannula, to the outlet opening in the pulmonary artery. Physicians and device operators monitor Impella RP System Catheter function on the display screen of the Automated Impella Controller.

The intent of the therapy with the Impella RP System is to provide a percutaneous circulatory support system to restore normal right heart hemodynamics, reduce right ventricular work, and allow the right heart time to potentially recover adequate contractile function or to be bridged to the next therapy.

This section describes the components of the Impella RP System Catheter and the Automated Impella Controller, as well as the accessory components.

REUSABLE SYSTEM COMPONENTS

The Impella RP® System consists of the following reusable components:

- Automated Impella Controller—provides the user interface, alarm indications, and portable battery
- Automated Impella Controller cart—for easy transport of the Automated Impella Controller

SINGLE-USE SYSTEM COMPONENTS

The Impella RP System also includes the following single-use components:

- Impella RP System Catheter
- Purge cassette
- Introducer kit
- 0.027 inch, 260cm placement guidewire
- Connector cable

SYSTEM CONFIGURATION

Figure 3.2 illustrates how the Automated Impella Controller connects to the Impella RP System Catheter and accessory components.

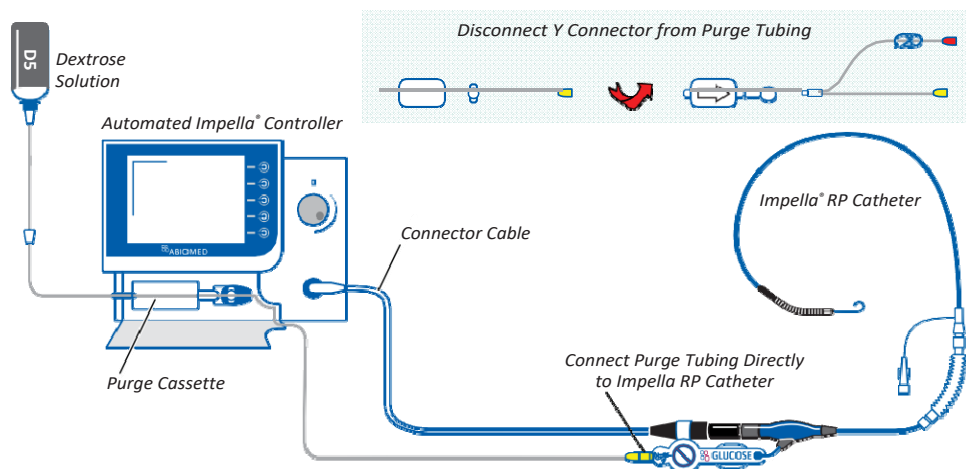

Figure 3.2 Automated Impella Controller, Impella RP System Catheter, and Accessories

IMPELLA RP® SYSTEM CATHETER

The Impella RP System Catheter is an intracardiac microaxial blood pump that delivers up to 4.0 liters of blood per minute from the inferior vena cava into the pulmonary artery. Figure 3.3 illustrates the Impella RP System Catheter. The Impella RP System Catheter has a specially designed three dimensional cannula that is sized to fit through the vessels and hearts of pediatric and adult patients with a Body Surface Area (BSA) equal to or greater than 1.5 m². Table 3.1 describes each component from the pigtail at one end to the check valve on the other end.

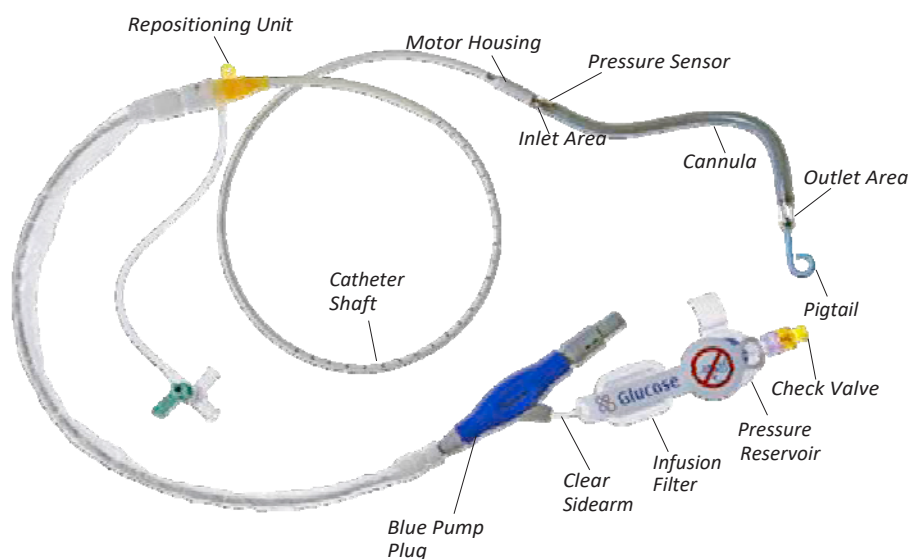

Figure 3.3 Impella RP System Catheter

Table 3.1 Impella RP System Catheter Components

Component	Description
Pigtail	The 6 Fr pigtail is attached to the cannula at the distal end of the outlet area. It assists with stabilizing the catheter in the correct position in the pulmonary artery.
Outlet area	The outlet area, located at the distal tip of the cannula, has 5 openings (windows) that allow blood to exit the cannula.
Cannula	The 22 Fr cannula is designed for the anatomy of the right heart, to provide optimal and stable position during operation. The cannula is made of nitinol and covered in polyurethane with spiral shaped reinforcement integrated into the cannula.
Differential pressure sensor	A sensor that measures the pressure difference between the inside and outside of the cannula. The pressure value is used for monitoring flow during catheter operation.

Table 3.1 Impella RP® System Catheter Components (continued)

Component	Description
Inlet area	The proximal end of the cannula is attached to the inlet area where blood enters the cannula.
Motor housing	The 21 Fr motor housing consists of an encapsulated motor.
Catheter shaft	An 11 Fr catheter shaft is located between the motor housing and the blue Impella plug. The lumen of the catheter shaft contains a purge lumen, an electrical cable, and a differential pressure measurement cable. The catheter shaft has transversal marks: <ul style="list-style-type: none">• The transversal marks at 1 cm intervals aid in proper positioning.
Repositioning unit	The repositioning unit consists of a sheath and an anticontamination sleeve with an anchoring ring. <ul style="list-style-type: none">• The 11 Fr sheath (15 Fr outer diameter) with hemostatic valve is located on the catheter shaft and allows repositioning of the catheter.• The anchoring ring of the anticontamination sleeve secures the sheath to the catheter; turning in the counterclockwise direction enables movement of the catheter and turning in the clockwise direction disables movement.
Blue Impella plug	The blue Impella plug has a clear sidearm and contains memory that retains operating parameters in case the patient needs to be transferred to another controller. The plug connects the Impella RP System Catheter to the Automated Impella Controller through a connector cable.
Clear sidearm	The clear sidearm is attached to the purge cassette tubing. It leads to the infusion filter, the pressure reservoir, and the check valve.
Infusion filter	The infusion filter prevents bacterial contamination and prevents air from entering the purge lumen.
Pressure reservoir	The pressure reservoir includes a flexible rubber diaphragm that provides additional filling volume by means of an expansion chamber during purge solution change.
Check valve	The yellow check valve ensures that purge fluid does not flow in the reverse direction when the purge solution is exchanged.

DIFFERENTIAL PRESSURE SENSOR

The Impella RP System Catheter has an electronic differential pressure sensor located at the proximal end of the cannula. The purpose of the pressure sensor is to generate the placement signal used to calculate the flow generated by the Impella RP System Catheter.

The pressure sensor is a flexible membrane integrated into the cannula. One side of the sensor is exposed to the blood pressure on the outside of the inlet area and the other side is exposed to the pressure of the blood inside of the cannula. The sensor generates an electrical signal proportional to the difference between the pressure outside the inlet area and the pressure inside the cannula. This signal is displayed on the Automated Impella Controller as the placement signal.

AUTOMATED IMPELLA CONTROLLER

The Automated Impella Controller (see Figure 3.4) provides three vital functions to the operation of the Impella RP® System Catheter:

- The controller provides an interface for monitoring and controlling the function of the Impella RP System Catheter
- The controller provides a fluid purge to the Impella RP System Catheter
- The controller provides backup power when the Impella RP System is operated away from AC power

The controller weighs 26 lbs (11.8 kg) and can operate on its internal battery for at least 60 minutes when fully charged. Using the controller, the Impella RP System can be used by trained healthcare professionals in healthcare facilities and during medical transport (ie, ambulance, helicopter, or fixed-winged aircraft) environments.

Automated Impella Controller operation is described in detail in section 4 of this manual.

Automated Impella Controller Battery Power

The controller can operate on its internal lithium-ion (Li-Ion) battery for at least 60 minutes when fully charged.



Figure 3.4 Automated Impella Controller – Front View

PURGE CASSETTE



Do **NOT** use saline in the purge system.

The purge cassette delivers rinsing fluid to the Impella RP® System Catheter. The purge fluid (typically 5% dextrose solution in water) flows from the purge cassette through the catheter to the microaxial blood pump to prevent blood from entering the motor. When the purge cassette is properly installed in the Automated Impella Controller, the Abiomed logo is upright and facing you. Figure 3.5 illustrates the purge cassette and related components. Table 3.2 describes each component.

Discard the Y Connector

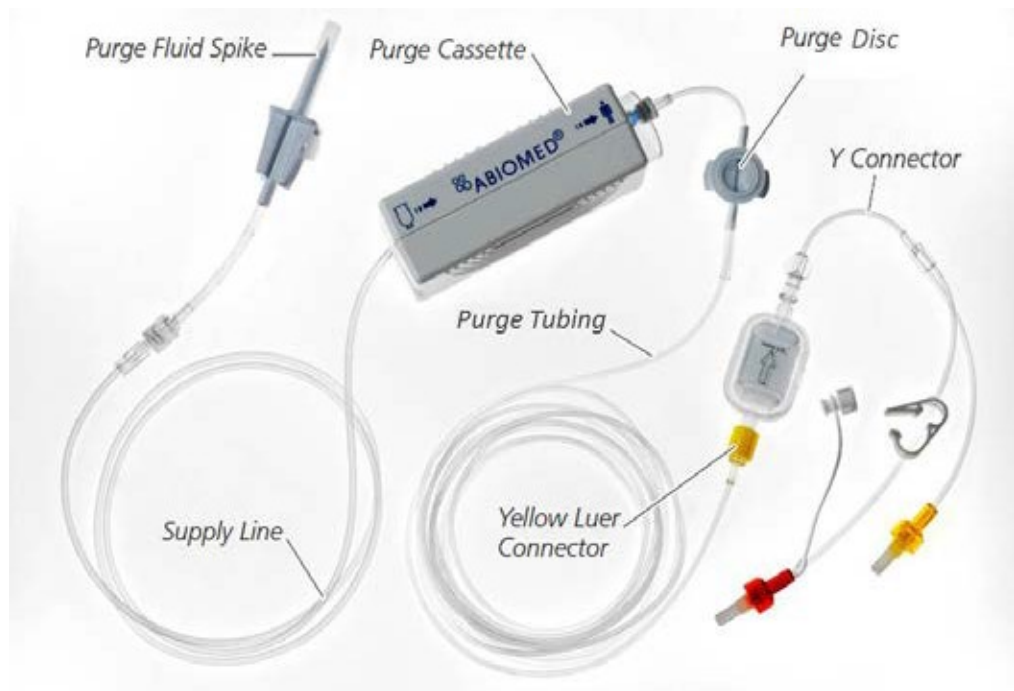

Figure 3.5 Purge Cassette

Table 3.2 Purge Cassette Components

Component	Description
Purge fluid spike	One end spikes the purge fluid bag and the other end connects the bag to the purge cassette supply line
Supply line	Carries fluid from the purge fluid bag to the purge cassette
Purge cassette	Contains the components for delivering the purge fluid; maintains the pressure barrier between the blood and the motor to prevent blood from entering the motor
Purge disc	Transmits pressure to the controller based on the purge pressure in the purge tubing; a sensor in the controller measures the pressure so that it can be displayed on the screen and used by the purge pressure algorithm to maintain the purge pressure
Purge tubing	Carries purge fluid from the purge cassette to the Impella RP® System Catheter
Yellow luer connector	Connects the purge tubing to the check valve (yellow luer lock) on the Impella RP System Catheter
Y connector	Adapter that connects the purge cassette tubing to the Impella Catheter; used with the Impella 2.5° Catheter but removed when you are using the Impella RP System Catheter

ACCESSORIES

Table 3.3 illustrates and describes the accessories used with the Impella RP® System Catheter and Automated Impella Controller.

Table 3.3 Impella RP System Catheter and Automated Impella Controller Accessories



Component	Description
 A coiled white connector cable with a black handle and a white plug at one end, and a blue socket at the other end.	<p>The white connector cable connects the Impella RP System Catheter to the Automated Impella Controller. Clips on the cable are used to secure the purge tubing to the cable.</p> <ul style="list-style-type: none">• The socket at the black end of the cable connects to the blue Impella plug.• The white plug at the opposite end of the cable is inserted into the blue catheter plug on the front of the Automated Impella Controller.
 A collection of medical devices including a long blue peel-away introducer with a dilator, several shorter dilators of different sizes (8 Fr, 12 Fr, 16 Fr, 20 Fr), and a guidewire.	<p>The introducer kit is used to place the Impella RP System Catheter. It contains:</p> <ul style="list-style-type: none">• 23 Fr peel-away introducer with dilator• 8 Fr, 12 Fr, 16 Fr, and 20 Fr supplemental dilators• 0.035 inch x 150 cm guidewire
 A long, thin, coiled placement guidewire with a blue handle at one end.	<p>The 0.027 inch, 260 cm placement guidewire is available for the placement of the Impella RP System Catheter.</p>

Figure 3.6 White Connector Cable

Figure 3.7 Introducer kit

Figure 3.8 Placement Guidewire

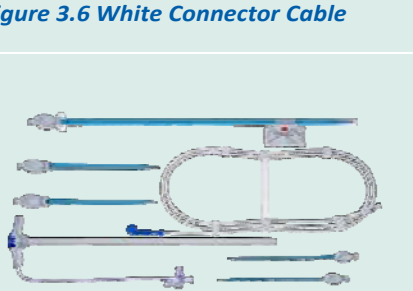
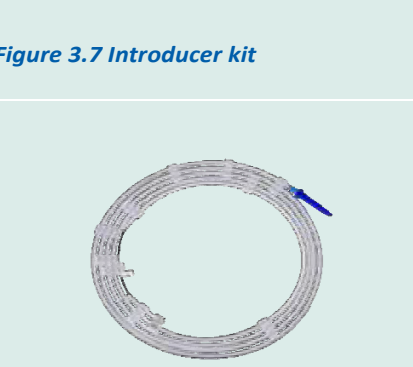
Table 3.3 Impella RP® System Catheter and Automated Impella Controller Accessories (continued)

Component	Description
	<p>Hospital Provided:</p> <p>Dextrose solution (typically 5% dextrose in water with 25 or 50 IU/mL of heparin) is used as the purge fluid through the Impella RP System Catheter.</p>
<p>Figure 3.9 Dextrose Solution</p>	<p>The Automated Impella Controller cart holds the Automated Impella Controller. The cart has wheels for easy transport of the controller and a storage basket. (For more information, including assembly instructions, refer to the Automated Impella Controller cart instructions for use.)</p>
	
<p>Figure 3.10 Automated Impella Controller Cart</p>	

4 USING THE AUTOMATED IMPELLA[®] CONTROLLER



OVERVIEW	4.1
AUTOMATED IMPELLA CONTROLLER FEATURES	4.1
AUTOMATED IMPELLA CONTROLLER DISPLAY	4.5
PLACEMENT SCREEN	4.8
Placement Signal Waveform	4.8
Motor Current Waveform	4.9
PURGE SCREEN	4.9
Purge Flow	4.10
Purge Pressure	4.10
INFUSION HISTORY	4.10
MOBILE OPERATION	4.11

OVERVIEW

The Automated Impella Controller is the primary user control interface for the Impella RP® System Catheter. It controls the Impella RP System Catheter performance and monitors the catheter for alarms. The controller can be powered by AC power or can operate on internal battery power for at least 60 minutes when fully charged.

AUTOMATED IMPELLA CONTROLLER FEATURES

IMPORTANT NOTE: The underside of the Automated Impella Controller has a battery switch to turn on the batteries. This switch is turned off for shipping purposes. Before operating the Automated Impella Controller for the first time, make sure you turn this switch on. If the battery switch is not turned on, the Automated Impella Controller will not be able to operate on battery power.

Selector Knob Function

Rotate the selector knob on the controller to navigate through menu items. Push the selector knob to confirm your selection.

Figure 4.1 illustrates the features on the front of the Automated Impella Controller. These features are described in Table 4.1.

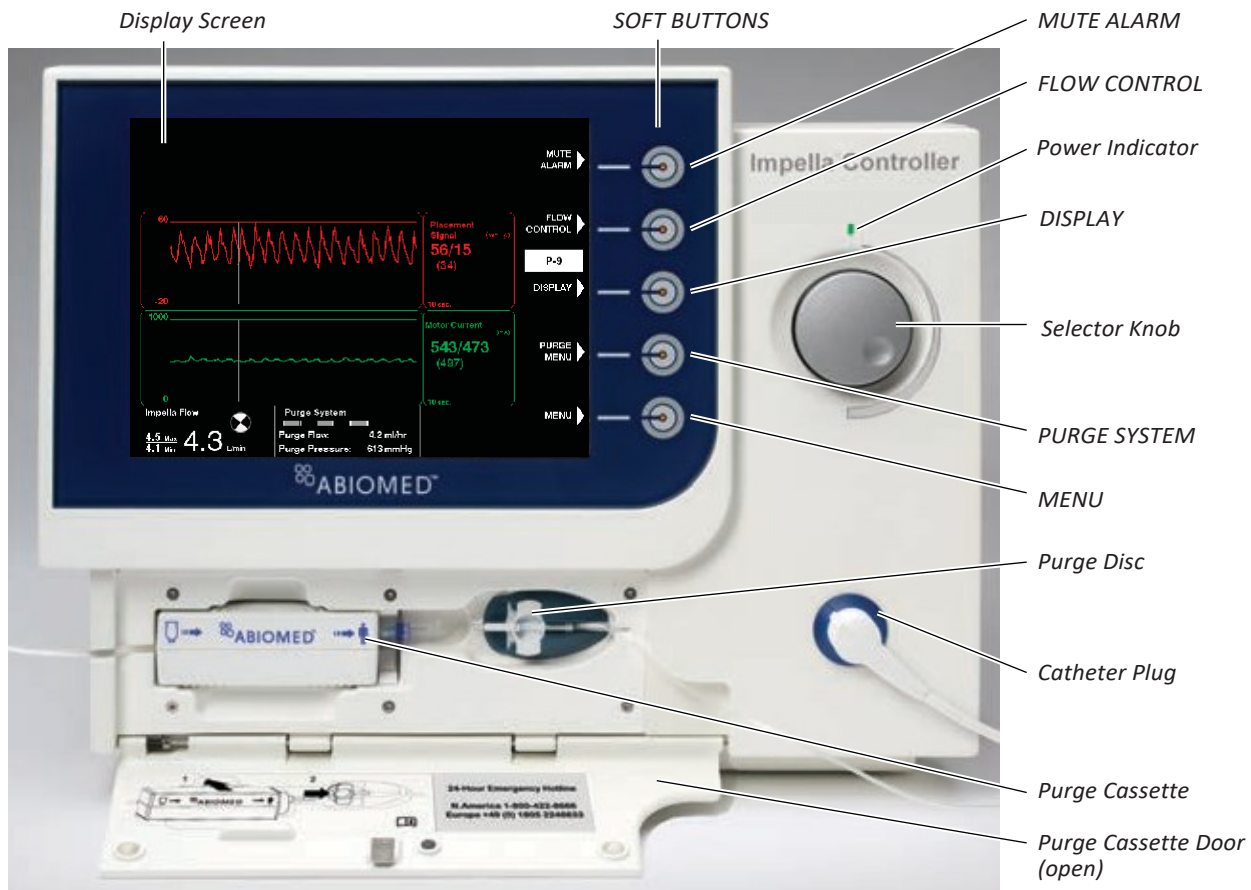

Figure 4.1 Automated Impella Controller Features – Front View

Display Options

If equipped with a VGA connector, the controller can be connected to a monitor to display information on another screen as described under “Slave Monitor Connection” in section 8 of this manual.

Table 4.1 Automated Impella Controller Front View Features

Feature	Description
Display screen	Displays user information, including the labels for the soft buttons. (Display screen elements described in detail later in this section.)
Soft buttons	Display, open, and close menus. The function for each soft button is defined by labels adjacent to the button on the display screen; function changes depending on the screen. (Soft button functions are described in Table 4.3.) When the Impella RP® System Catheter is running, the default soft button labels are as follows: <ul style="list-style-type: none">• MUTE ALARM• FLOW CONTROL• DISPLAY• PURGE MENU• MENU
Power indicator	LED light above the selector knob; indicates the power status of the Automated Impella Controller. <ul style="list-style-type: none">• Green light—controller is on and plugged into AC power or running on battery power• Amber light—controller is off but plugged into AC power• No light—controller is off and not plugged into AC power
Selector knob	Rotating push button; turn clockwise and counterclockwise to navigate through menu items; push to make a selection.
Purge Disc	A flexible diaphragm on the purge cassette tubing that applies pressure to the sensor in the controller so that purge pressure can be measured.
Catheter plug	Connection point on the controller for the connector cable that connects to the Impella RP System Catheter.
Purge cassette	Contains the components for delivering the purge fluid; maintains the pressure barrier between the blood and the motor to prevent blood from entering the motor. (The purge cassette and its components are described in section 3 of this manual.)
Purge cassette door	Spring-loaded door that opens to provide access to the purge cassette.

Figure 4.2 illustrates the features on the left and right sides of the Automated Impella Controller. These features are described in Table 4.2.

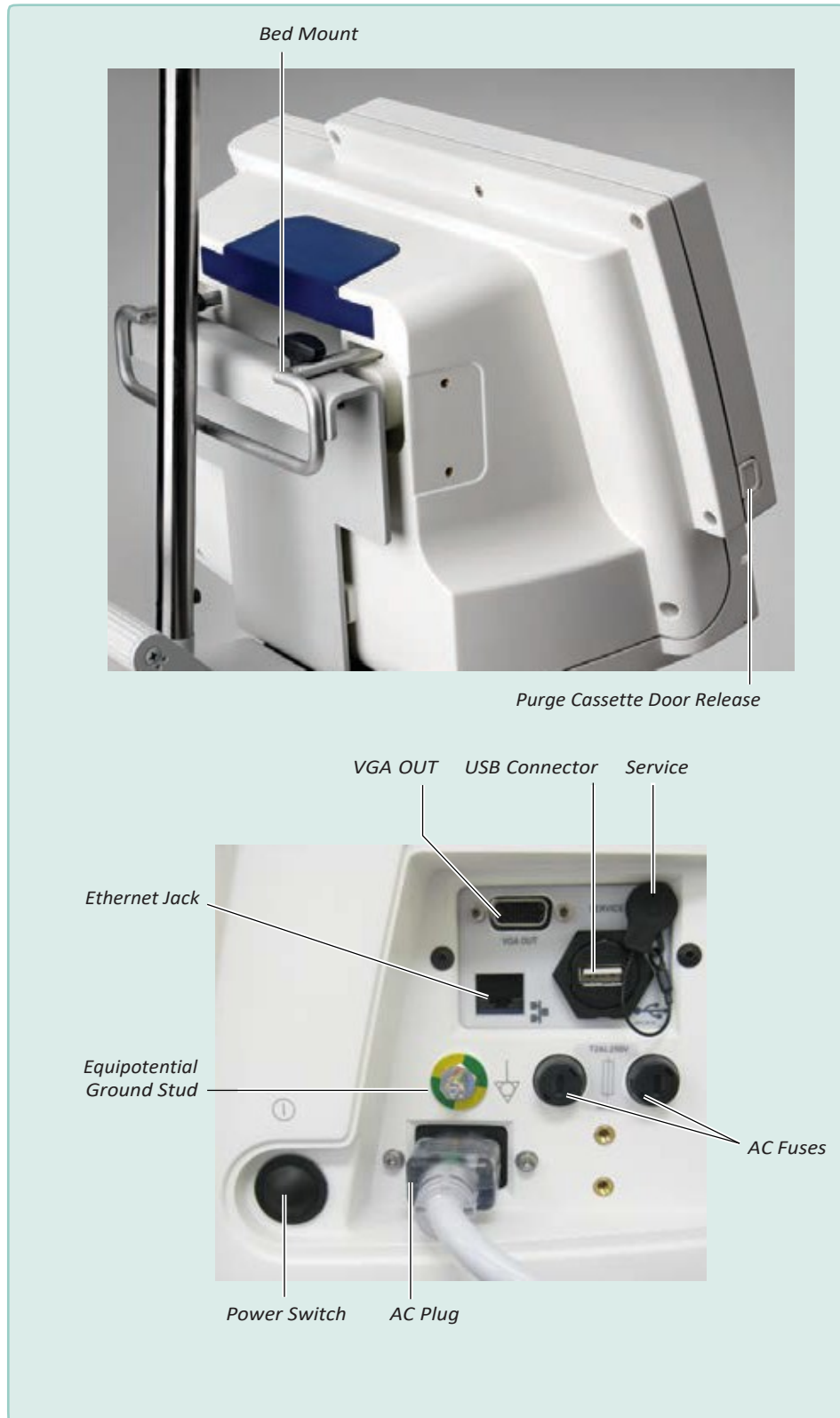

Figure 4.2 Automated Impella Controller Features – Side Views

Table 4.2 Automated Impella Controller Side View Features

Feature	Description
Bed mount	Metal bracket on the back of the controller; attaches controller to the cart or bed
Purge cassette door release	Button located on the left side of the controller; press to open the purge cassette door
VGA/ RS-232 jack	Interface for data transfer by Abiomed maintenance or service personnel; if equipped, this interface can also be used for connecting the controller to another monitor to slave the display
USB connector	Connection for data downloading by Abiomed maintenance or service personnel
AC fuses	Electrical safety device in the event of current overload
AC plug	Connection point on the controller for the AC power cord
Power switch	<p>Button that turns the controller on or off</p> <ul style="list-style-type: none"> • ON: Press and hold the power switch for 3 seconds • OFF: (1) Disconnect the Impella RP® System Catheter from the Automated Impella Controller (2) Press and hold the power switch for 3 seconds (3) A pop-up confirmation box will appear (4) Press OK using the selector knob to confirm that the controller should be turned off <p>NOTE: Holding down the power switch for longer than 30 seconds during operation will cause the controller to initiate an emergency shutdown</p>
Equipotential ground stud	Used to ground the Automated Impella Controller according to hospital procedures
Ethernet jack	Connection for downloading data or software upgrades

AUTOMATED IMPELLA CONTROLLER DISPLAY

The Automated Impella Controller screens have several common display elements. Each element is shown in Figure 4.3 and described in Table 4.3.

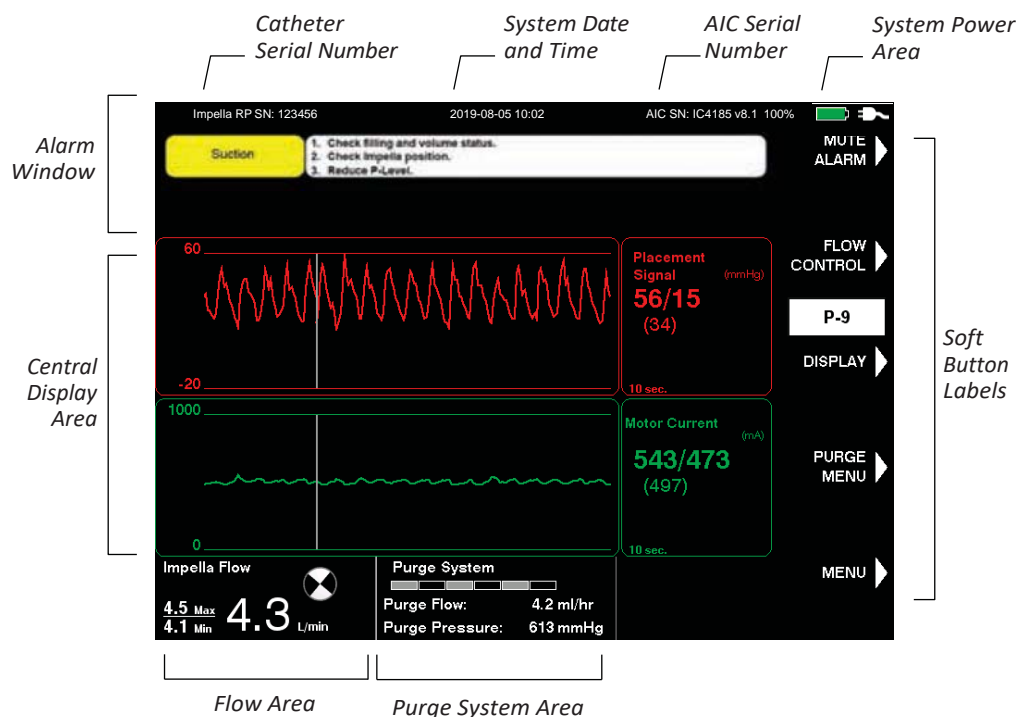

Figure 4.3 Automated Impella Controller Display Elements - Screen View

Table 4.3 Automated Impella Controller Display Elements

Display Element	Description
Alarm window	<p>The alarm window displays up to 3 alarms simultaneously, in order of priority from top to bottom.</p> <p>For each alarm, the alarm window displays:</p> <ul style="list-style-type: none"> Alarm header – displayed in the left column; window is color-coded red for critical alarms, yellow for serious alarms, white for advisory notifications, gray for resolved alarms Alarm subhead (if applicable) – further describes the alarm condition Detailed text – up to 3 lines of instructions for resolving the alarm condition are displayed in the right column of the alarm window next to the alarm header and subhead information <p>(See section 7 of this manual for further discussion of alarms.)</p>
Catheter serial number	Displayed in the upper left of the display screen if a catheter is connected to the controller.
System date and time	The current date (YYYY-MM-DD) and time (24-hour format; HH:MM) are displayed in the upper center of the screen display. (In this example it is August 5, 2019 at 10:02am.)
Automated Impella Controller Serial Number and SW version	The AIC serial number and the current SW version are shown in the upper right of the display screen

Purge System Stabilization

The purge system must stabilize after case start, a purge procedure, or resolution of a purge alarm. During this time, it may take up to 3 minutes for purge system information to display on the screen.

Table 4.3 Automated Impella Controller Display Elements (continued)

Display Element	Description
Mute alarm indicator	<p>Displayed in place of the words “MUTE ALARM” when an alarm is silenced. (See section 7 of this manual for more information about the mute alarm function; Figure 7.1 illustrates the mute alarm indicator.)</p> <ul style="list-style-type: none"> • Yellow bell with red X displayed when an alarm is muted • Not displayed when an alarm is active (but not muted) or when there are no active alarms
Soft button labels	<p>The soft buttons on the Automated Impella Controller have corresponding labels adjacent to them on the display screen. These labels change depending on the type of screen displayed. (Refer to Appendix A in this manual for more details about the menu structure.)</p> <p>MUTE ALARM - Mutes (silences) active alarms</p> <p>FLOW CONTROL - Allows you to control the flow of the Impella Catheter</p> <p>DISPLAY - Brings up the Display menu for viewing waveforms and navigating to other screen displays</p> <p>PURGE MENU - Brings up the Purge Menu for changing the purge fluid, purge cassette and fluid or de-airing the purge system.</p> <p>MENU - Brings up a menu of options related to controller settings, alarm history and starting a case.</p> <p>Additional soft button functions may appear during specific controller procedures.</p> <p>START - Starts the specified procedure.</p> <p>NEXT - Advances to the next screen</p> <p>CANCEL - Exits out of the current menu.</p> <p>BACK - Returns to the previous screen</p> <p>EXIT - Exits the current procedure.</p> <p>DONE - Done completes the current step or procedure.</p>
System power area	<p>System power information is displayed to the right of the AIC Serial Number and software information at the top right of the display screen.</p> <p>Battery status – Bar within battery symbol indicates the overall remaining capacity of the batteries</p> <ul style="list-style-type: none"> • Full green bar for fully charged battery • Partial green bar for battery that is at least 50% charged • Partial yellow bar for battery that is between 16% and 50% charged • Partial red bar for battery that is less than or equal to 15% charged • Moving gray bar for battery that is in charging mode • Numeric percentage of battery power remaining displayed below the battery icon <p>AC plug indicator</p> <ul style="list-style-type: none"> • Green plug indicates that the controller is running on AC power • Gray plug with a red X indicates no AC power detected and the controller is running on battery power

Table 4.3 Automated Impella Controller Display Elements (continued)

Display Element	Description
Purge system area	<p>Information about the purge system is displayed to the right of the flow area at the bottom of the display screen.</p> <p>Purge system marquee—scrolls from left to right when purge system is operating</p> <ul style="list-style-type: none"> • Slow scrolling represents normal purge flow rate • Fast scrolling represents bolus flow rate <p>Purge flow</p> <ul style="list-style-type: none"> • Current purge flow displayed in mL/hr below the purge system marquee if the purge flow is known • Not displayed when the purge system is stabilizing, when there is no purge cassette, or when the procedure has not yet started • Current purge pressure (pressure of the purge fluid delivered through the catheter to the motor) displayed in mmHg below the purge flow
Flow area	<p>Information about Impella RP® System Catheter flow is displayed in the lower left corner of the display screen.</p> <p>Max/Min</p> <ul style="list-style-type: none"> • Max/Min displays the range for the flow rate <p>Current flow rate</p> <ul style="list-style-type: none"> • Mean catheter flow displayed in liters per minute (L/min) • If the system is unable to calculate flow, a yellow triangular caution icon is displayed with the message “Flow Calculation Disabled” <p>Catheter operation icon</p> <ul style="list-style-type: none"> • The circular catheter operation icon rotates when the Impella RP System Catheter is running
Central display area	<p>On the placement screen, the central display area displays two waveform signals, described in the “Placement Screen” discussion below.</p>

PLACEMENT SCREEN

The placement screen (see Figure 4.4) displays real-time operating data for the system. The screen displays the placement signal and motor current waveforms as well as the maximum/minimum and average values for each waveform in the central display area of the screen.

Use the **DISPLAY** soft button to navigate to the placement screen.

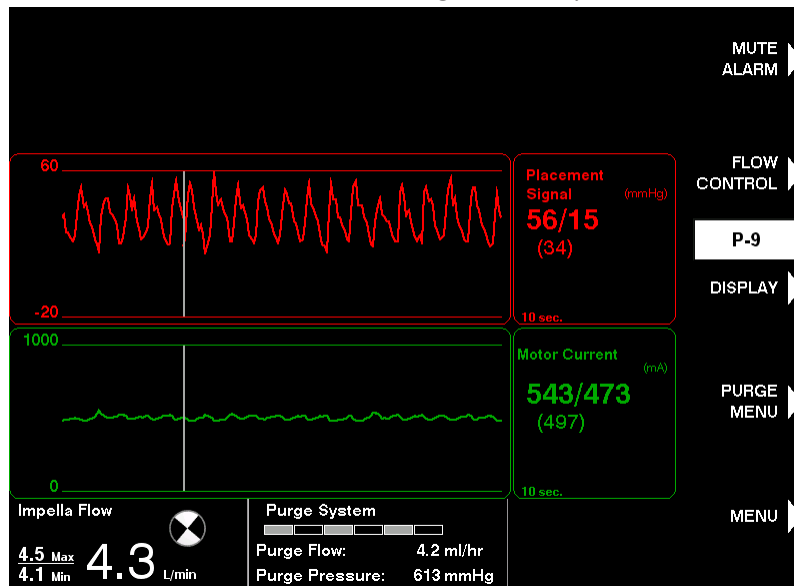

Figure 4.4 Placement Screen

Figure 4.4 shows two time-based waveform signals from different sources.

- Placement signal waveform
- Motor current waveform

PLACEMENT SIGNAL WAVEFORM

The placement signal waveform displays a pressure measurement from the differential pressure sensor. The scale for the placement signal waveform is displayed to the left of the waveform. The scale can be adjusted in increments of 10 mm Hg.

To the right of the waveform is a display that labels the waveform, provides the units of measurement, and shows the maximum and minimum values and the average value from the samples received. At the bottom of that window is the time scale, which you can set by pressing the **DISPLAY** soft button.

MOTOR CURRENT WAVEFORM

Motor current is a measure of the energy intake of the Impella RP® System Catheter motor. The energy intake varies with motor speed and the pressure difference between the inlet and outlet areas of the cannula.

The scale for the motor current waveform is displayed to the left of the waveform. The default scaling is 0–1000 mA. It is adjustable in 100 mA increments for the Impella RP System Catheter, with a minimum difference between upper and lower limits of 200 mA and a maximum difference of 1000 mA.

To the right of the waveform is a display that labels the waveform, provides the units of measurement, and shows the maximum and minimum values and the average value from the samples received. You can set the time scale at the bottom of that window by pressing the **DISPLAY** soft button.

PURGE SCREEN

The purge screen (see Figure 4.5) displays purge system data. In the central display area of the screen, the purge flow rate and purge pressure are plotted as a function of time. To the right of the plots, the current purge flow rate and purge pressure are displayed.

Use the **DISPLAY** soft button to navigate to the purge screen.

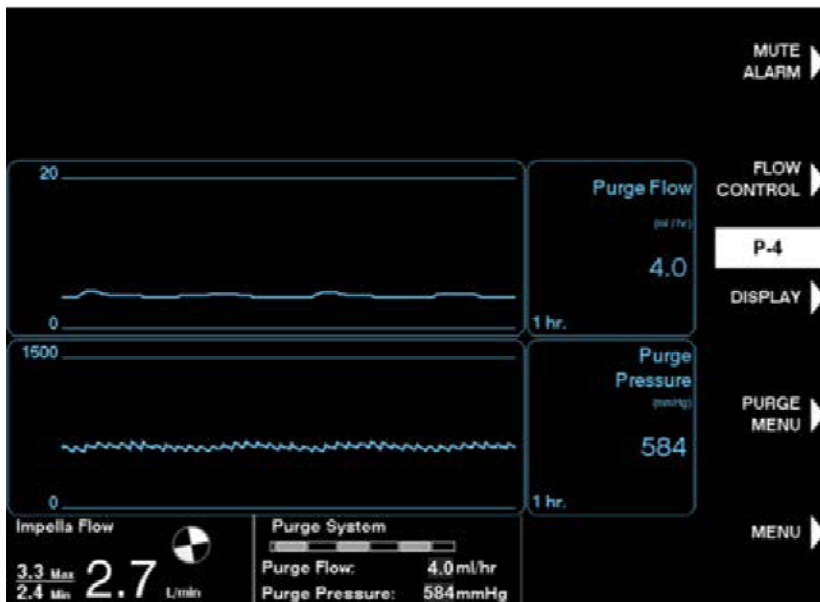

Figure 4.5 Purge Screen

PURGE FLOW

The purge flow rate delivered by the purge cassette is displayed in mL/hr. The standard scale for the purge flow (0–30 mL/hr) is displayed to the left of the purge flow plot. The maximum value on this scale can be adjusted from 20 mL/hr to 200 mL/hr in increments of 10 mL/hr.

To the right of the plot is a display that labels the plot and shows the most recent value update. You can set the time scale at the bottom of the window by pressing the **DISPLAY** soft button.

An Advisory Alarm can also be turned on via the **SETTINGS** menu.

PURGE PRESSURE

The purge pressure generated by the purge cassette is displayed in mmHg. The standard scale for the purge pressure (0–1500 mmHg) is displayed to the left of the purge pressure plot. The maximum value on this scale can be adjusted from 100 mmHg to 2000 mmHg in increments of 100 mmHg.

To the right of the plot is a display that labels the plot and shows the most recent value update. You can set the time scale at the bottom of the window by pressing the **DISPLAY** soft button.

INFUSION HISTORY

The infusion history screen displays the infusion volume as well as the amount of heparin and dextrose infused each hour. The current time period is displayed at the top of the list. The calculations begin when the case start procedure is completed and Impella RP® System Catheter flow rate is greater than 0 L/min. The infusion history screen updates after each milliliter of purge fluid is delivered and after each unit of heparin and dextrose is delivered.

Use the **DISPLAY** soft button to navigate to the infusion history screen.

Figure 4.6 shows a sample infusion history screen.



Figure 4.6 Infusion History Screen

The heparin infused via the Impella purge system should be monitored and included in institutional anti-coagulation protocols. Failure to do so, may result in excessive heparin being infused, which may cause increased bleeding at the percutaneous and surgical access sites. Additional information on use of the heparin infusion for anti-coagulation can be found in Section 5 (see Anti-coagulation Therapy with Impella Heparin Infusion on page 5.4).

MOBILE OPERATION



The Li-Ion batteries must be charged for 5 hours prior to system operation in order to meet the runtime requirement of 1 hour. Failure to do so will yield a shorter runtime. After being unplugged, the Automated Impella Controller will operate for at least 60 minutes after the batteries have been fully charged.

The Automated Impella Controller can be operated on internal battery power when it is not connected to AC power.

Disconnect the Automated Impella Controller from AC power.

The Automated Impella Controller beeps once every 5 minutes to alert you that it is running on battery power and a white advisory notification appears in the alarm area on the screen. The AC power icon turns gray with an X through it.

When the Automated Impella Controller is connected back to AC power, the white advisory notification turns gray and the AC power icon turns green.



5 USING THE AUTOMATED IMPELLA CONTROLLER WITH THE IMPELLA RP® SYSTEM CATHETER

IMPELLA RP PATIENT SELECTION	5.1
ANTI-COAGULATION THERAPY WITH IMPELLA HEPARIN INFUSION.....	5.4
STARTUP	5.7
Supplies Needed.....	5.7
Turning on the Automated Impella Controller.....	5.8
The Startup Screen	5.9
CASE START	5.10
Case Start.....	5.10
Insert Purge Cassette.....	5.11
Connect the Connector Cable	5.12
Enter Purge Fluid Data	5.14
Secure the Purge Tubing	5.15
Impella RP System Configuration	5.16
INSERTING THE IMPELLA RP® SYSTEM CATHETER	5.16
POSITIONING AND STARTING THE IMPELLA RP® SYSTEM CATHETER	5.18
USE OF THE REPOSITIONING SHEATH AND THE 23 FR PEEL-AWAY INTRODUCER.....	5.19
P-LEVELS	5.20
SUCTION	5.20
PURGE CASSETTE PROCEDURES	5.21
Change Cassette and Bag.....	5.21
Change Purge Fluid Bag	5.22
De-Air Purge System	5.23
Air Detected Alert.....	5.23
TROUBLESHOOTING THE PURGE SYSTEM.....	5.24
Purge Pressure Low	5.24
Purge System Open	5.24
Purge Pressure High and Purge System Blocked	5.25
PATIENT WEANING	5.25
REMOVING THE IMPELLA RP® SYSTEM CATHETER	5.26

IMPELLA RP PATIENT SELECTION



Benefits of Impella RP in salvage patients have not been proven.

The Impella RP patient indication and its contraindications are listed in Section 1 of this Impella RP IFU document. In order to guide Impella RP users to optimal patient outcomes, Impella RP patient selection guidance is an important element. Noted below, in the following figures, are definitions and a flow chart for enabling patient selection for Impella RP based on the premarket studies that will result in optimal outcomes.

Please note in Figure 5.2 that the “best practices pathway” is highlighted in green and is derived from PMA studies inclusion and exclusion criteria. Patients who follow the green pathway should have the best chance to benefit from Impella RP and the outcomes data for these patients can be found in Section 6 of this IFU. The alternate pathway (“the gray pathway”) represents patients who fall outside of the PMA studies guidelines, but still can be served with Impella RP. These patients are likely salvage patients and the benefit of Impella RP in these patients has not been proven.

The Table 5.1 “Checklist” is another useful tool for guiding optimal patient selection for Impella RP. Like the Figure 5.2, this list should be used to identify patients who are most likely to benefit from Impella RP and also to identify those who may not.

<p style="text-align: center;">RIGHT VENTRICULAR FAILURE Cardiac Index <2.2 L/min/m² despite continuous High Dose Inotropes <small>(As defined in the RECOVER RIGHT Clinical Trial)</small></p> <p>AND ANY OF THE FOLLOWING:</p> <ul style="list-style-type: none"> • CVP¹ >15 mmHg or • CVP/PCWP¹ or LAP >0.63 or • Moderate to severe global RV dysfunction on echo defined as one of the following¹: <ul style="list-style-type: none"> - Global RV hypokinesia or - TAPSE score of ≤14 mm or - RV diameter at base >42 mm or - RV short axis (or mid-cavity) diameter >35 mm <hr/> <p>High Dose Inotropes defined as:</p> <ul style="list-style-type: none"> • Dobutamine of ≥10 µg/kg/min or equivalent for more than 15 minutes • Milrinone >120 minutes • Or administration of more than one inotrope/vasopressor medication 	<p>Profound Cardiogenic Shock defined:</p> <ul style="list-style-type: none"> • SBP <75mmHg • CI <1.3 l/min/m² <p>despite two or more high dose inotropes</p> <ul style="list-style-type: none"> • PH <7.1 not corrected by 100 mEq NaHCO₃ • DIC • Anoxic brain Injury or CGS >24 hrs
	<p style="text-align: center;">Additional Measure for Early Identification of Right Ventricular Failure</p> <div style="display: flex; justify-content: space-around; align-items: center;"> <div style="text-align: center;"> $PAPF < 1.0$ </div> <div style="text-align: center;"> $PAPI = \frac{PAS - PAD}{RA}$ </div> </div> <ul style="list-style-type: none"> • PAPI = Pulmonary Artery Pulsatility Index • PAS = Pulmonary Artery Systolic Pressure • PAD = Pulmonary Artery Diastolic Pressure • RA = Mean Right Arterial Pressure

1. Anderson MB, et al. *J Heart Lung Transplant.* 2015; 34(12):1549-1560

2. Korabathina, R et al. *The Pulmonary Artery Pulsatility Index Identifies Severe Right Ventricle Dysfunction in Acute Inferior Myocardial Infarction.* *SCAI* 2012; 80:593-600

Figure 5.1 Best Practices - Patient Selection Guidance with Right Ventricular Failure - Impella RP Heart Pump

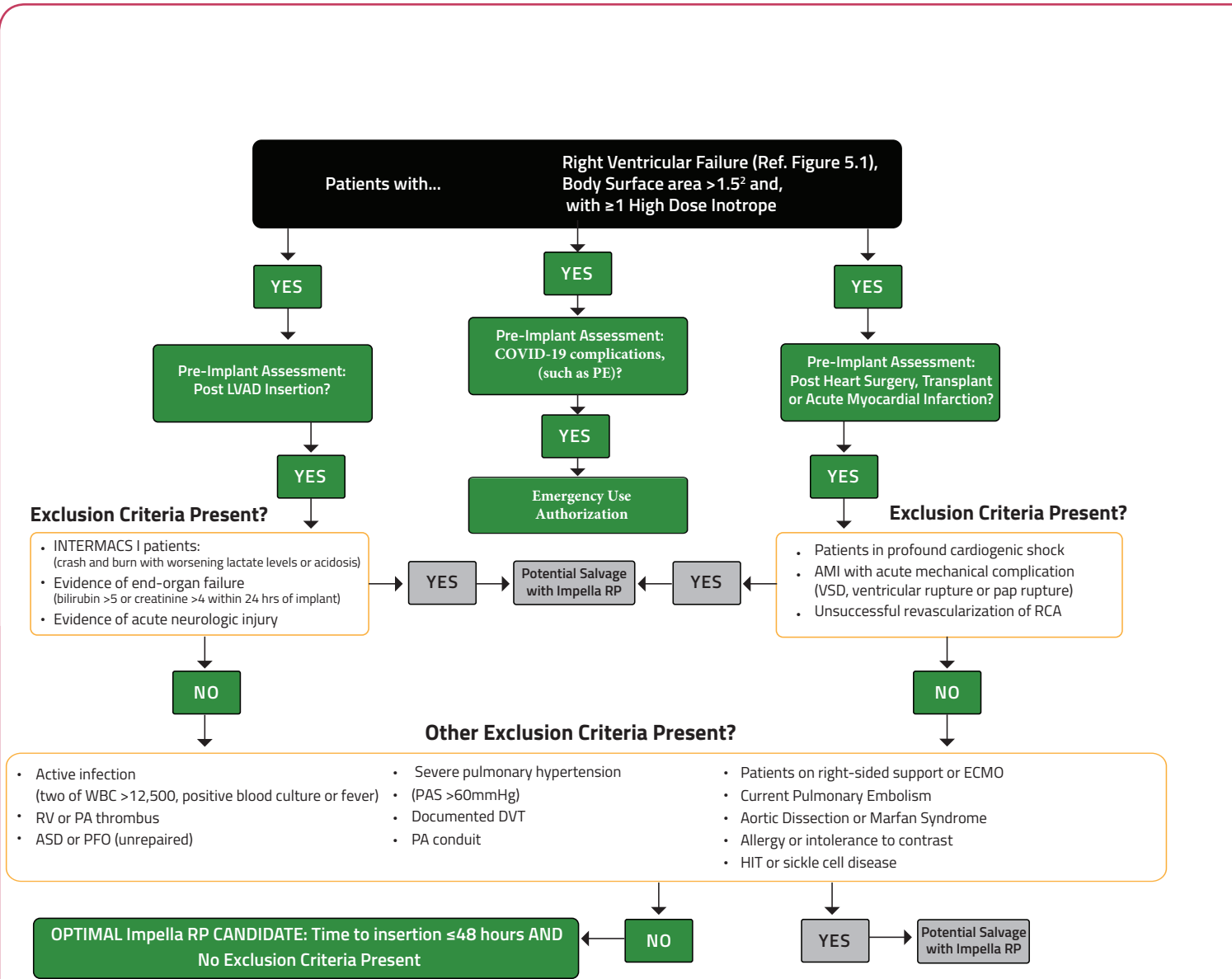

Anderson MB, et al. *J Heart Lung Transplant.* 2015; 34(12):1549-1560

Figure 5.2 Impella RP Best Practice Selection Algorithm

Below you will find an RP Patient Selection Criteria Checklist that can be used to optimize patient outcomes with Impella RP.

Treatment with the Impella RP System is appropriate for patients who develop signs of acute right ventricular failure:

1. Post-implantation of an approved surgical LVAD; or
2. Post-heart surgery, post-heart transplant or post-myocardial infarction

The checklists below are based on the exclusion criteria for the Impella RP pre-market clinical study. These checklists are provided to help you determine if Impella RP support is an appropriate treatment for your patient, and may predict whether your patient is likely to benefit from Impella RP support.

Table 5.1 Exclusion Criteria for the Impella RP Pre-Market Clinical Study

Pre-Implant Assessment: Post LVAD Insertion	Pre-Implant Assessment: Post Heart Surgery, Transplant or Acute Myocardial Infarction
<input type="checkbox"/> Time (hours) to insertion post LVAD implant _____ hrs	<input type="checkbox"/> Time (hours) to insertion post completion of Cardiac Surgery or Heart Transplant, or presentation with Acute Myocardial Infarction _____ hrs
<input type="checkbox"/> INTERMACS I patients (crash and burn with worsening lactate levels or acidosis)	<input type="checkbox"/> Patients in profound cardiogenic shock
<input type="checkbox"/> Evidence of end-organ failure (bilirubin >5 or creatinine >4 within 24 hours of implant)	<input type="checkbox"/> AMI with acute mechanical complication (VSD, ventricular rupture or pap rupture)
<input type="checkbox"/> Evidence of acute neurologic injury	<input type="checkbox"/> Unsuccessful revascularization of RCA
<input type="checkbox"/> Active infection defined as two of the following (WBC >12,500 or positive blood culture or fever)	<input type="checkbox"/> Active infection defined as two of the following (WBC >12,500 or positive blood culture or fever)
<input type="checkbox"/> RA, RV or PA thrombus	<input type="checkbox"/> RA, RV or PA thrombus
<input type="checkbox"/> Prosthetic valves in the right heart	<input type="checkbox"/> Prosthetic valves in the right heart
<input type="checkbox"/> Structural tricuspid disease	<input type="checkbox"/> Structural tricuspid disease
<input type="checkbox"/> ASD or PFO (unrepaired)	<input type="checkbox"/> ASD or PFO (unrepaired)
<input type="checkbox"/> Pulmonary valve stenosis or insufficiency	<input type="checkbox"/> Pulmonary valve stenosis or insufficiency
<input type="checkbox"/> Severe pulmonary hypertension (PAS >60mmHg)	<input type="checkbox"/> Severe pulmonary hypertension (PAS >60mmHg)
<input type="checkbox"/> Documented DVT and/or presence of IVC filter	<input type="checkbox"/> Documented DVT and/or presence of IVC filter
<input type="checkbox"/> Anatomic abnormalities precluding insertion	<input type="checkbox"/> Anatomic abnormalities precluding insertion
<input type="checkbox"/> PA conduit	<input type="checkbox"/> PA conduit
<input type="checkbox"/> Patients on right-sided support or ECMO	<input type="checkbox"/> Patients on right-sided support or ECMO
<input type="checkbox"/> Current Pulmonary Embolism	<input type="checkbox"/> Current Pulmonary Embolism
<input type="checkbox"/> Aortic Dissection or Marfan Syndrome	<input type="checkbox"/> Aortic Dissection or Marfan Syndrome
<input type="checkbox"/> Allergy or intolerance to contrast	<input type="checkbox"/> Allergy or intolerance to contrast
<input type="checkbox"/> HIT or sickle cell disease	<input type="checkbox"/> HIT or sickle cell disease
<input type="checkbox"/> Existing congenital heart disease that would preclude placement	<input type="checkbox"/> Existing congenital heart disease that would preclude placement
OPTIMAL CANDIDATE: Time to insertion ≤48 hours AND no boxes checked	OPTIMAL CANDIDATE: Time to insertion ≤48 hours AND no boxes checked

ANTI-COAGULATION THERAPY WITH IMPELLA HEPARIN INFUSION

To maximize reliability, Impella pump motors require a constant purge using a dextrose solution in water with heparin (25 or 50 U/ml). In addition, Impella pumps are used in conjunction with heparin based anti-coagulation therapy. As a result, the heparin infused via the Impella purge system needs to be accounted for in institutional protocols, which include heparin for systemic anti-coagulation. Abiomed's recommendation on an optimal method to include Impella heparin infusion into an anti-coagulation protocol is provided below.

INCLUDING IMPELLA HEPARIN INFUSION IN HEPARIN ANTI-COAGULATION THERAPY

Anti-coagulation therapy protocols are extremely important for managing Impella pumps. These protocols usually include the use of heparin for systemic anti-coagulation, and careful monitoring of a patient's coagulation status using Activated Clotting Times (ACTs). During support with Impella pumps, the targeted ACT is 160-180 seconds. Depending on each patient's characteristics, different heparin doses are needed to maintain this ACT. This is accomplished by providing intravenous (IV) heparin infusions to maintain an optimal coagulation state, as monitored by ACT.

To optimize patient management on Impella support, anti-coagulation therapy utilizing heparin needs to account for the heparin delivered through the Impella purge system. Specifically, the heparin infused via the purge solution may provide a significant fraction of the heparin needed to maintain a patient's ACT. As a result, failure to account for the Impella heparin infusion can confound ACT maintenance, and potentially result in patients being in a hyper-coagulated state, leading to increased bleeding at the percutaneous and surgical access sites. A method to include Impella heparin infusion in an anti-coagulation protocol using heparin is described below.

Overall, the total heparin to a patient is the sum of the Impella Delivered Heparin (Heparin source: Impella purge), and the IV Heparin (Heparin source: drip):

$$\text{Total Heparin} = \text{Impella Delivered Heparin} + \text{IV Heparin} \quad (1)$$

If your protocol does not include an allowance for heparin from the Impella purge, but calls out a specific total heparin, the IV Heparin can be calculated as:

$$\text{IV Heparin} = \text{Total Heparin} - \text{Impella Delivered Heparin} \quad (2)$$

As a sample patient case, if your protocol specifies to use heparin at 10 U/kg/hour to maintain an acceptable ACT, and you have a 100 kg patient, your total heparin would be 1,000 U/hour. If the Infusion History Screen on the AIC (see Figure 4.6) shows that the Impella purge provides 150 U/hour (50 U/mL heparin at a purge rate of 3 mL/hour), using equation (2), the correct IV Heparin would be 850 U/hour of heparin or 8.5 mL/hour for a saline bag with 100 U/mL. Table 5.2 provides additional clinical scenarios.

Table 5.2 Clinical scenarios for anti-coagulation therapy with the Impella purge system heparin (50 U/ml).

Scenario #1 – Total heparin = 8 U/kg/hour; IV Heparin Concentration = 100 U/mL		
Patient Weight (kg)	Impella Purge[^] Flow (mL/hour)	IV Heparin (mL/hour)
75	10	1
	15	-1.5 [†]
	20	-4 [†]
100	10	3
	15	0.5
	20	-2 [†]
125	10	5
	15	2.5
	20	0*
Scenario #2 - Total heparin = 10 U/kg/hour; IV Heparin Concentration = 100 U/mL		
Patient Weight (kg)	Impella Purge[^] Flow (mL/hour)	IV Heparin (mL/hour)
75	10	2.5
	15	0*
	20	-2.5 [†]
100	10	5
	15	2.5
	20	0*
125	10	7.5
	15	5
	20	2.5
Scenario #3- Total heparin = 12 U/kg/hour; IV Heparin Concentration = 100 U/mL		
Patient Weight (kg)	Impella Purge[^] Flow (mL/hour)	IV Heparin (mL/hour)
75	10	4
	15	1.5
	20	-1 [†]
100	10	7
	15	4.5
	20	2
125	10	10
	15	7.5
	20	5

[^] Impella purge heparin = 50 U/mL
^{*} scenario where discontinuation of systemic heparin therapy should be assessed.
[†] scenario where use of Impella purge heparin = 25 U/mL should be assessed.

As noted in Table 5.2 (denoted with *), for some patients, the Impella purge system may provide a full heparin dose (IHD = THD). For these patients, systemic IV heparin therapy may not be needed. In addition, for other patients (denoted with †), the Impella purge system may provide too much heparin. For these patients, in order to maintain an optimal ACT, use of a purge fluid with a lower heparin concentration (25 U/mL) should be considered. Table 5.3 provides a corrected patient scenarios table for these cases.

Table 5.3 Patient scenarios for anti-coagulation therapy with the Impella purge system heparin (25 U/mL).

Scenario #1 – Total heparin = 8 U/kg/hour; IV Heparin Concentration = 100 U/mL		
Patient Weight (kg)	Impella Purge† Flow (mL/hour)	IV Heparin (mL/hour)
75	15	2.25
75	20	1
100	20	3
Scenario #2 – Total heparin = 10 U/kg/hour; IV Heparin Concentration = 100 U/mL		
Patient Weight (kg)	Impella Purge† Flow (mL/hour)	IV Heparin (mL/hour)
75	20	2.5
Scenario #2 - Total heparin = 10 U/kg/hour; IV Heparin Concentration = 100 U/mL		
Patient Weight (kg)	Impella Purge^ Flow (mL/hour)	IV Heparin (mL/hour)
75	20	4
† Impella purge heparin = 25 U/mL		

Please contact Abiomed’s Clinical Support Center, 1-800-422-8666, if you have questions.

STARTUP



Do **NOT** use an Impella RP® System if any part of the system is damaged.



The sterile components of the Impella RP System can be used only if the sterilization indicators show that the contents have been sterilized, the packaging is not damaged, and the expiration date has not elapsed.



Do **NOT** resterilize or reuse the Impella RP System Catheter. It is a disposable device and is intended for single use only. Reuse, reprocessing, or reesterilization may compromise the structural integrity of the catheter and/or lead to catheter failure which, in turn, may result in patient injury, illness, or death.



To prevent malfunction of the Automated Impella Controller, avoid long-term exposure to direct sunlight and excessive heat (40°C).



To prevent overheating and improper operation, do **NOT** block the cooling vents of the Automated Impella Controller while it is operating.



The Li-Ion batteries must be charged for 5 hours prior to system operation in order to meet the runtime requirement of 1 hour. Failure to do so will yield a shorter runtime. After being unplugged, the Automated Impella Controller will operate for at least 60 minutes after the batteries have been fully charged.



Have a backup Automated Impella Controller, purge cassette, connector cable, and Impella RP System Catheter available in the unlikely event of a device failure.

SUPPLIES NEEDED

- Automated Impella Controller
- Impella RP System Catheter and accessories
- Femoral length, balloon-tipped flow-directed catheter
- 500 cc bag of dextrose solution for purge solution in water (5% recommended; 5% to 20% acceptable) with 25 or 50 IU heparin/mL

TURNING ON THE AUTOMATED IMPELLA CONTROLLER™

To turn the controller on:

1. Press and hold the power switch on the right side of the Automated Impella Controller for 3 seconds (see Figure 5.3).

Battery Switch

Before operating the Automated Impella Controller for the first time, turn on the switch on the underside of the controller to turn on the batteries.

*Power Switch
on Right Side of
Impella® Controller*



Figure 5.3 Automated Impella Controller Power Switch

The Automated Impella Controller automatically performs a system test when turned on.

A display bar shows the progress of the system test. If the system test passes, the system displays the startup screen (see Figure 5.4).

If the system test fails, the controller displays a system self check failure message:

SYSTEM SELF CHECK FAILED.
CHANGE CONSOLE IMMEDIATELY.

The controller displays the reason for the system test failure at the bottom of the screen.

THE STARTUP SCREEN

The startup screen (see Figure 5.4) appears when you successfully turn on the Automated Impella Controller.

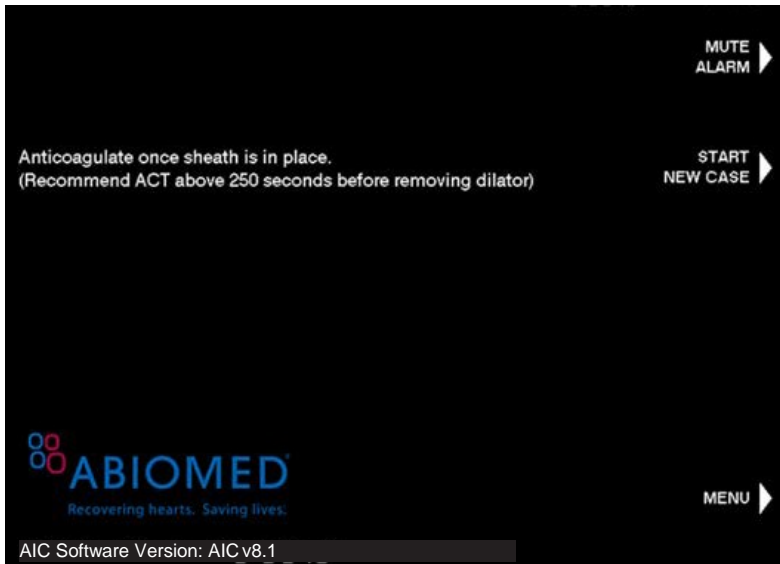

Check Date and Time

The current date and time appear at the top of the startup screen. Confirm that these are correct.

Figure 5.4 Automated Impella Controller Startup Screen

The startup screen displays the current version of the software that the Automated Impella Controller is running:

The startup screen also displays system power information along the bottom of the screen and three active soft buttons—**MUTE ALARM**, **START NEW CASE**, and **MENU**—along the right side of the screen.

CASE START

Sensitive Medical Device

The Impella RP System Catheter is a sensitive medical device with extremely fine tolerances. In particular, the inlet and outlet areas of the catheter assembly may be damaged if subjected to strong external forces.



Fluoroscopy is required to guide placement of the Impella RP® System Catheter. The small placement guidewire must be reliably observed at all times.



The sterile components of the Impella RP System can be used only if the sterilization indicators show that the contents have been sterilized, the packaging is not damaged, and the expiration date has not elapsed.



Avoid manual compression of the inlet, outlet, or sensor areas of the cannula assembly.



Do **NOT** remove the Impella RP System Catheter over the length of the placement guidewire.



Handle with care. The Impella RP System Catheter can be damaged during removal from packaging, preparation, insertion, and removal. Do **NOT** bend, pull, or place excess pressure on the catheter or mechanical components at any time.



Do **NOT** kink or clamp any part of the Impella RP System Catheter.

CASE START

1. Press the **START NEW CASE** soft button from the startup screen or plug in a new Impella Catheter. “CaseStart” can also be selected by pressing the MENU soft key.
2. The controller displays the screen shown in Figure 5.5.

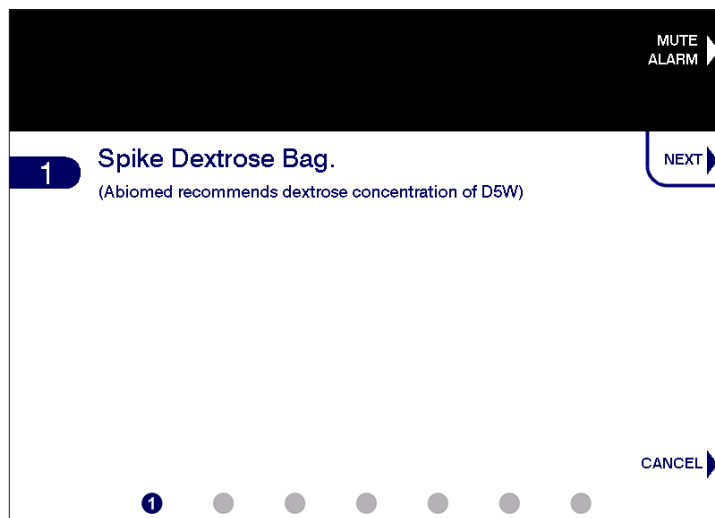

Figure 5.5 Initial Case Start Screen.

INSERT PURGE CASSETTE

1. Open the purge cassette package. If included, disconnect and discard the Y connector. Secure the YELLOW luer to the sterile field.
2. Pass the purge cassette and spike off the sterile field.
3. Spike the fluid bag/bottle.
4. Press the **NEXT** soft button.
5. Open the purge cassette door by pressing the release on the left side of the controller. Insert the purge cassette into the Automated Impella Controller (as shown in Figure 5.6 and described in the steps that follow).



Figure 5.6 Inserting the Purge Cassette into the Automated Impella Controller

6. The purge cassette snaps into a molded compartment on the front of the controller. Follow the diagram on the inside of the purge cassette door for proper placement.
7. Slide the purge disc into the slot to the right of the purge cassette until it snaps into place. The controller will automatically begin priming the purge cassette.
8. Extend the purge tubing and close the purge cassette door. There is sufficient room around the edges of the purge cassette door so that it will not pinch the purge tubing as it exits.

Shaded Steps

All shaded steps require sterile technique.

Discard the Y Connector

After opening the purge cassette package, disconnect and discard the Y connector if included. The Y connector is only used with the Impella 2.5 and Impella CP Catheter.

Connect Purge Disc Within 3 Seconds

The instructions for inserting the purge disc appear if it is not snapped into place within 3 seconds of inserting the purge cassette.

Purge Solution Bottles

If the purge solution is supplied in bottles, open the vent on the purge fluid spike and follow the same procedure as if supplied in bags.

Close Purge Cassette Door

Once the purge cassette is installed, be sure to close the purge cassette door to prevent the purge cassette from being dislodged accidentally.

CONNECT THE CONNECTOR CABLE

1. Remove the Impella RP® System Catheter from its package using sterile technique and inspect the catheter, including its connector, for damage.
2. Remove the white connector cable from its package using sterile technique.
3. Inspect the cable for damage, including damage to the connector pins at the controller end.
4. Secure the grey end of the cable to the sterile field.
5. Insert the catheter plug into the connector cable socket (grey end). The tab and the slot must be aligned during connection (see Figure 5.7).

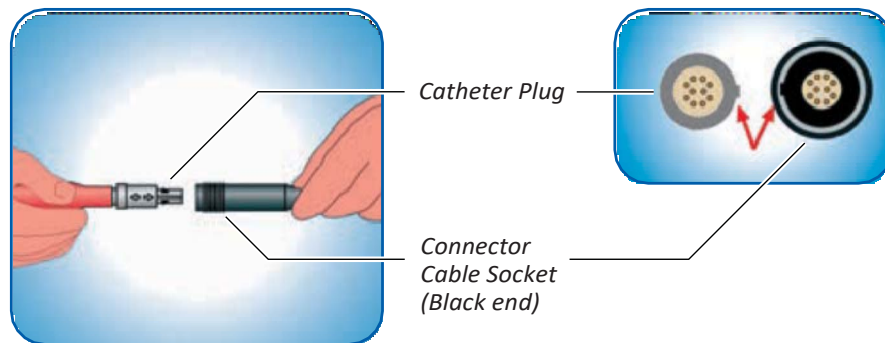

Figure 5.7 Inserting the Catheter Plug into the Connector Cable

6. Pull back on the connection to make sure that the plug has snapped into place.
7. Snap the plastic clip (located on the pressure reservoir of the clear sidearm) to the connector cable as shown in Figure 5.8.

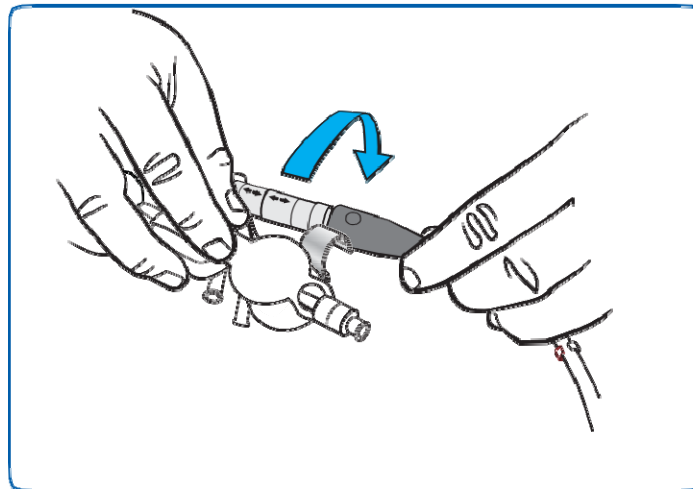

Figure 5.8 Snapping Purge Clip to Connector Cable

8. Pass the sterile connector cable from the Impella RP System Catheter off the sterile field.
9. Line up the notch on the connector cable with the notch in the blue catheter plug on the front of the Automated Impella Controller and plug the cable into the controller.
10. If you have not already done so, disconnect and discard the Y connector with the red and yellow luers from the purge tubing if included.

Important Step

Snapping the purge clip on the pressure reservoir to the connector cable is important to prevent the tube from kinking.

11. Connect the yellow luer on the end of the purge tubing to the yellow luer on the clear sidearm of the Impella RP® System Catheter as shown in Figure 5.9.

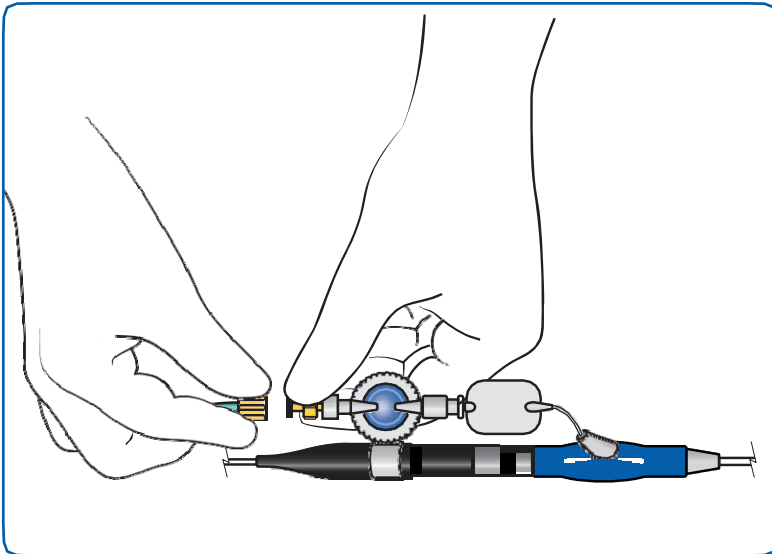

Figure 5.9 Connecting the Luer to the Impella RP System Catheter

12. When the controller detects that the luer is connected, it automatically begins priming the purge lumen.

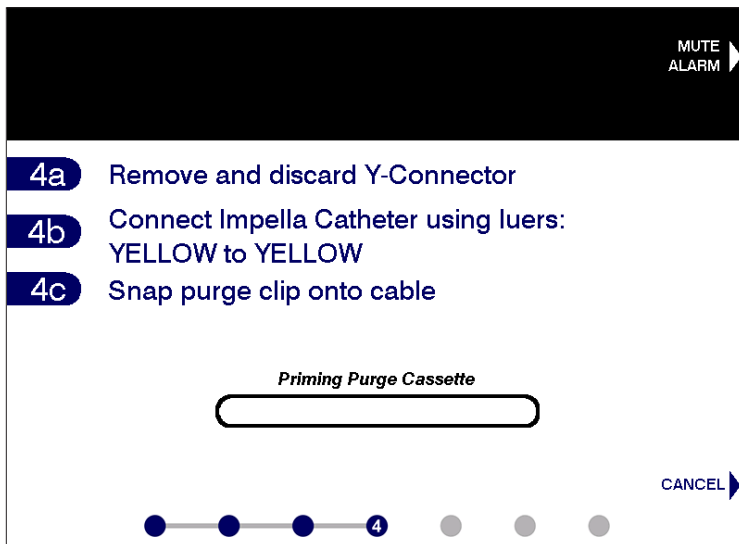

Figure 5.10 Priming the Purge

ENTER PURGE FLUID DATA

1. Enter the purge fluid information. The screen in Figure 5.11 shows a table of default values for the purge fluid.

Purge Fluid Volume	500 ml
Dextrose Concentration	5 %
Heparin Concentration	50 IU/ml

Figure 5.11 Entering Purge Fluid Information

2. To select the default values displayed on the screen, press the **ACCEPT** soft button. This will select those values and automatically advance to the next screen. Note: The Automated Impella Controller will use the default values for the purge fluid unless changed.
3. To change the purge fluid information, press the **EDIT** soft button, scroll to the appropriate item and push the selector knob to select it or use the white soft arrow buttons. Then scroll through the values and push the selector knob to make a new selection. Press the **DONE** button to finish editing. The controller will use the default values if no other selections are made.
 - Purge fluid can be set to 50 mL, 100 mL, 250 mL, 500 mL (default), or 1000 mL.
 - Dextrose concentration can be set to 5% (default), 10% or 20%.
 - Heparin concentration can be set to 0 (default), 5 IU/mL, 6.25 IU/mL, 10 IU/mL, 12.5 IU/mL, 15 IU/mL, 20 IU/mL, 25 IU/mL, 40 IU/mL or 50 IU/mL (default).

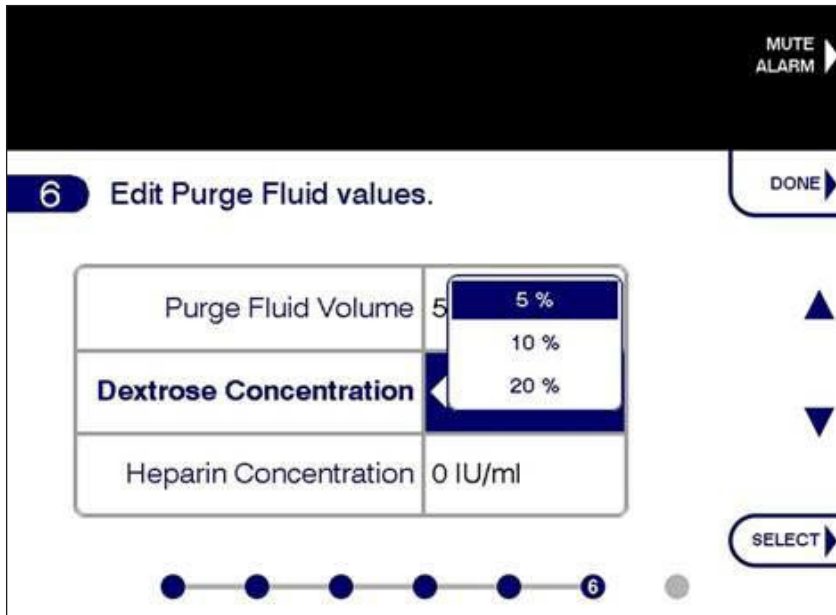

Figure 5.12 Changing Purge Fluid Information

SECURE THE PURGE TUBING

1. To complete the setup, connect the purge tubing to the white connector cable by pushing the purge tubing into the clips attached to the white connector cable as shown in Figure 5.13.



Figure 5.13 Connecting the Purge Tubing to the Connector Cable

IMPELLA RP SYSTEM CONFIGURATION

Figure 5.14 illustrates the correct configuration of the Impella RP System.

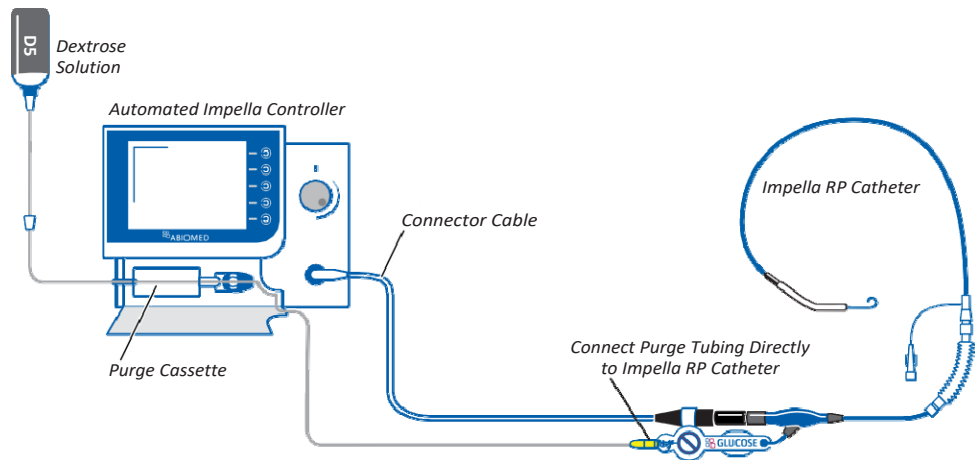

Figure 5.14 Impella RP System Configuration

INSERTING THE IMPELLA RP® SYSTEM CATHETER

NOTE – Proper surgical procedures and techniques are the responsibility of the medical professional. The described procedure is furnished for information purposes only. Each physician must evaluate the appropriateness of the procedure based on his or her medical training and experience, the type of procedure, and the type of systems used.



Fluoroscopy is required to guide placement of the Impella RP System Catheter. The small placement guidewire must be reliably observed at all times.



Avoid manual compression of the inlet, outlet, or sensor areas of the cannula assembly.



Do **NOT** kink or clamp any part of the Impella RP System Catheter.



Handle with care. The Impella RP System Catheter can be damaged during removal from packaging, preparation, insertion, and removal. Do **NOT** bend, pull, or place excess pressure on the catheter or mechanical components at any time.

1. Confirm purge fluid is exiting the Impella Catheter.
2. Obtain access to the femoral vein.
3. Insert a 5–8 Fr introducer over the 0.035 inch guidewire (provided) to pre-dilate the vessel.
4. Remove the 5–8 Fr introducer over the 0.035 inch guidewire. Insert the 8 Fr, 12 Fr, 16 Fr, and 20 Fr dilators sequentially, as needed. Remove the 20 Fr dilator and insert the 23 Fr introducer with dilator. While inserting the 23 Fr introducer, hold the shaft of the introducer to advance it into the vein.
5. Administer heparin. When ACT is at least 250 seconds, remove the 23 Fr dilator.
6. Insert a flow-directed balloon-tipped catheter into the 23 Fr introducer and advance it over a guidewire into the left (preferred) or right pulmonary artery, if needed.
7. Remove the 0.035 inch diagnostic guidewire, leaving the diagnostic or balloon-tipped catheter in the pulmonary artery. Form a curve or bend on the 0.027 inch, 260 cm placement guidewire and then insert it.
8. Advance the placement guidewire deep into the LPA until wire prolapses.
9. Remove the diagnostic or balloon-tipped catheter.
10. Wet the cannula with sterile water and backload the catheter onto the placement guidewire. One or two people can load the catheter on the guidewire.
 - a. Advance the guidewire into the Impella RP® System Catheter and stabilize the cannula between the fingers. The scrub assistant can help stabilize the catheter by holding the catheter proximal to the motor. The physician can focus on advancing the guidewire and, if the cannula needs to be hyperextended, the scrub assistant is available to assist.
11. Advance the catheter through the hemostatic valve into the femoral vein and along the placement guidewire using a fixed-wire technique. Follow the catheter under fluoroscopy, and rotate the catheter as it enters the right ventricle to direct the cannula tip upward and across the pulmonary valve. Position the outlet area of the cannula approximately 4 cm past the pulmonary valve annulus. NOTE: While the entire pump is in the abdominal IVC, calibrate the sensor by pressing the Zero Sensor soft button.
12. Remove the placement guidewire.
13. Confirm position with fluoroscopy.

Shaded Steps

All shaded steps require sterile technique.

Use Fluoroscopy for Placement

Impella RP System Catheter performance will be compromised if correct placement cannot be confirmed. While other imaging techniques, such as transesophageal echocardiography (TEE), can help confirm the position of the Impella RP System Catheter after placement, TEE does not allow visualization of the entire catheter assembly and is inadequate for reliably placing the Impella RP System Catheter.

POSITIONING AND STARTING THE IMPELLA RP® SYSTEM CATHETER



Retrograde flow will occur from the pulmonary artery back into the inferior vena cava if the Impella RP System Catheter is set at performance level P-0.

When the Impella RP System is properly positioned across the pulmonary valve, but is not yet running, the placement signal will be similar to a pulmonary arterial waveform. After starting the Impella RP System the amplitude of the placement signal will increase by a factor of 2 to 2.5, depending on the selected performance level.

1. Press the **START IMPELLA** soft button.
2. Turn the selector knob to increase P-level from P-0 to P-2.
3. Press the selector knob to select the new performance level.
4. Press the YES soft button to confirm after P-level is selected.
5. The catheter operation icon in the lower left corner of the screen begins rotating when the Impella RP System Catheter begins to operate.
6. Increase P-level to P-9 to confirm correct and stable placement. Evaluate the catheter position and remove any excess slack. The catheter inlet area should be in the inferior vena cava and the outlet area in the pulmonary artery. Verify placement with fluoroscopy.

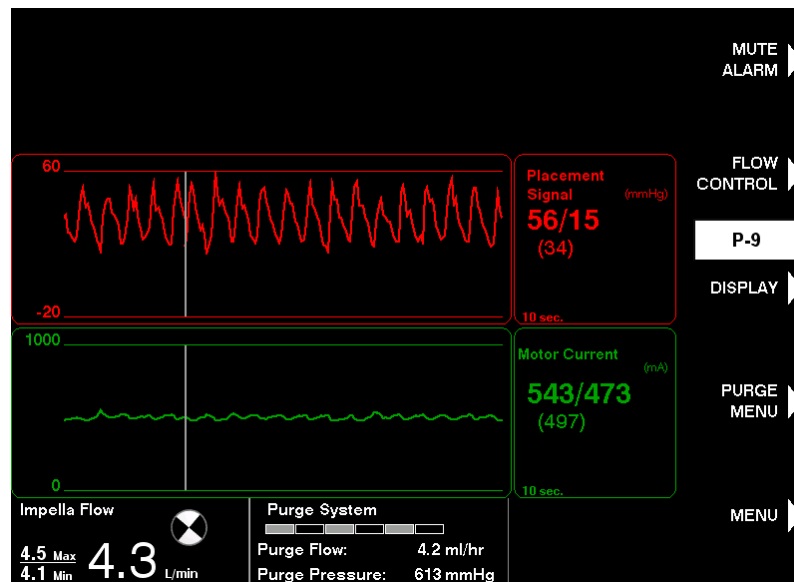

Figure 5.15 Maximum Performance Level

USE OF THE REPOSITIONING SHEATH AND THE 23 FR PEEL-AWAY INTRODUCER

1. Flush the sidearm of the repositioning sheath located on the catheter shaft.
2. Attach a stopcock and flush the repositioning sheath prior to advancing the sheath.
3. Apply manual pressure above the puncture site and remove the 23 Fr peel-away introducer completely from the vein over the catheter shaft.
4. Grasp the two wings and bend back until the valve assembly comes apart. To do this, first stretch then snap the flexible valve mechanism that temporarily holds the two wings together. Continue to peel the two wings until the introducer is completely separated from the catheter shaft. NOTE: Do NOT peel the 23 Fr peel-away introducer over the tip of the repositioning sheath.
5. Place two dead-end caps on the repositioning sheath stopcock to prevent further usage. The sideport should not be used to give medication or draw blood because the blood could potentially clot. Pressure bags should not be connected to the sideport of the repositioning sheath. If a pressure bag is connected, the sideport must have an infusion pump or flow limiting valve in place to control the amount of fluid administered to the patient.
6. Slide the repositioning sheath over the catheter shaft and advance it into the femoral vein to the yellow eyelet.
7. Make sure there is no bleeding at the transition from the repositioning sheath to the femoral vein. Close and dress the wound.
8. Secure the repositioning sheath by suturing it to the skin using the yellow eyelet on the sheath.
9. Attach the anticontamination sleeve to the yellow section of the repositioning sheath. Lock the anchoring ring in place by turning it clockwise. Secure the catheter shaft in place by tightening the connected anchoring ring.
10. Carefully extend the anticontamination sleeve to maximum length and secure the end closest to the blue Impella plug by tightening the anchoring ring.
11. Reposition the catheter as necessary.

To prevent contamination and subsequent infections, always use sterile technique on the insertion site. Follow institutional protocols for prophylaxis of infection for patients on ventricular assist devices and indwelling lines, as well as protocols for surveillance of such patients. If device-related infection occurs, consider each patient's clinical circumstances when deciding whether to continue Impella support.

P-LEVELS

You can select one of ten P-Levels (P-0 to P-9) as shown in Table 5.4. Flow rate is increased by approximately 10% with every additional performance level, but depends on preload and afterload and can vary due to suction or incorrect positioning. Select the lowest performance level that will enable you to achieve the flow rate necessary for patient support.

Table 5.4 P-Level Flow Rates

P-Level	*Flow Rate (L/min)
P-0	0.0
P-1	0.0 – 1.2
P-2	0.0 – 1.6
P-3	0.0 – 2.0
P-4	1.3 – 2.9
P-5	1.6 – 3.1
P-6	2.4 – 3.5
P-7	3.0 – 4.0
P-8	3.4 – 4.2
P-9	3.9 – 4.4

**Flow rate depends on preload and afterload and can vary due to suction or incorrect positioning.*

At P-levels between P-1 and P-6, the Impella RP® System operates with a regularly recurring rapid speed pulse. This minimizes stasis and reduces the risk of thrombosis in the motor area.

SUCTION

If suction is an issue, the flow displayed on the controller may be higher than the actual Impella RP System flow rate. If the suction alarm appears on the controller when the Impella RP System is running at P-levels between P-7 and P-9, decrease P-level as needed to resolve suction.

Retrograde flow

Retrograde flow will occur from the pulmonary artery back into the inferior vena cava if the Impella RP System Catheter is set at P-0. Retrograde flow may also occur at P-1.

PURGE CASSETTE PROCEDURES



When replacing the purge cassette, the replacement process must be completed within 90 seconds after disconnecting luer(s). The Impella RP® System Catheter may be damaged if replacement takes longer than 90 seconds.

There are three procedures for maintaining the Impella RP System Catheter purge system:

- Change Purge Cassette and Bag
- Change Purge Fluid Bag
- De-Air purge system

Each procedure can be accessed using the **PURGE MENU** soft button. This section describes each of these purge cassette procedures.

CHANGE CASSETTE AND BAG

Purge cassette change out may be required if extended use of the Impella Catheter and purge cassette is required. Follow these steps to change both the purge cassette and purge fluid:

1. Press **PURGE MENU** and select “Change Cassette and Bag” from the menu.
2. Select **START** to begin the cassette and fluid change process.



Figure 5.16 *Disconnecting the Y Connector from the Purge Cassette Tubing*

3. When prompted by the controller, disconnect the luer(s) from the Impella catheter.
4. Open the purge cassette door by pressing the button on the left side of the console. Remove and discard the old cassette and purge fluid bag.
5. Open the new purge cassette. Spike the new purge fluid bag with the new purge cassette tubing. Select **NEXT** to continue.

Discard the Y Connector

If included, disconnect and discard the Y connector from the purge cassette tubing.

Purge Solution Bottles

If the purge solution is supplied in bottles, open the vent on the purge fluid spike and follow the same procedure as if supplied in bags.

Priming Purge Cassette Fluid

It may be helpful to flush the fluid from the purge cassette to ensure the tubing is primed with the new dextrose concentration when changing bags.

Disconnecting Luers

The system only prompts you to remove luers and prime and flush tubing if the heparin or dextrose concentrations were changed or air was detected. You can only select SKIP PRIME if no air was detected.

6. Insert the new purge cassette into the controller. Be sure to slide the purge disc into place and extend the purge tubing through the gap in the purge cassette door when you close the door.
7. Confirm the luer(s) are disconnected. Press **NEXT** to proceed to prime the purge cassette.
8. Update the purge fluid information.
 - a. To select the default purge fluid values displayed on the screen, select **CONFIRM**.
 - b. To change the purge fluid information, select **EDIT**. Then use the soft keys to navigate selections and edit values. Select **DONE** to complete editing.
9. When purging is complete, connect the luer(s) from the new purge cassette to the Impella catheter.

CHANGE PURGE FLUID BAG

These are the steps you will follow to change only the purge fluid.

1. Press **PURGE MENU** and select "Change Purge Fluid Bag."
2. Select **START** to begin the purge fluid change process.
3. When prompted by the controller, remove the old purge bag and replace by spiking the new purge fluid bag. Select **NEXT** to advance to the next step.
4. Update the purge fluid information.
 - a. To select the default purge fluid values displayed on the screen, select **CONFIRM**.
 - b. To change the purge fluid information, select **EDIT**. Then use the soft keys to navigate selections and edit values. Select **DONE** to complete editing.
5. When prompted by the controller, disconnect the luer(s) from the Impella Catheter. The controller will automatically prime the tubing, which will flush the fluid from the last bag out of the purge cassette tubing. **Note:** the instructions to disconnect the luer(s) and to automatically prime the tubing only occurs if the user changed the purge fluid concentration
 - a. To skip the flush, select **SKIP PRIME**.
6. When prompted by the controller, connect the yellow luer from the purge cassette to the Impella catheter.

DE-AIR PURGE SYSTEM

These are the steps you will follow to de-air the purge system.

1. Press **PURGE MENU** and select “De-Air Purge System.”
2. Select **START** to begin the de-air process.
3. Make sure that the purge fluid bag is NOT empty or inverted and that the tubing is NOT kinked. Select **NEXT** to continue.
4. Disconnect the purge tubing from the Impella Catheter.
5. Confirm that no air remains in the purge tubing. If air remains, press **BACK** to repeat the air removal process.
6. Connect the purge tubing to the Impella Catheter to complete the de-air procedure.

AIR DETECTED ALERT

During any of the purge system processes above, the controller automatically monitors for air in the system. If air is detected in the system, the controller provides an alert to disconnect the luer(s) as shown in Figure 5.17. Once the luer(s) are disconnected, the controller automatically de-airs the purge system.

De-air Procedure

You may run the de-air procedure (described earlier in this section) after changing the dextrose concentration to decrease the amount of time it takes for a change in purge pressure/flow to occur.



Figure 5.17 Air Detected Alert

Purge Pressure

Optimal purge pressure is different for every Impella RP System Catheter. Purge pressure can range from 300 mmHg to 1100 mmHg. While purge pressure varies during operation, the Automated Impella Controller automatically maintains purge pressure within an acceptable range for each Impella RP System Catheter.

Purge System Open Alarm

This alarm may occur if purge pressure is less than 100 mmHg.

TROUBLESHOOTING THE PURGE SYSTEM

PURGE PRESSURE LOW



If at anytime during the course of support with the Impella RP[®] System Catheter, the Automated Impella Controller alarms “Purge Pressure Low,” follow the instructions below.

1. Inspect the purge system for leaks.
2. If there are no leaks, change to a purge fluid with a higher dextrose concentration. To do this, open the **PURGE MENU** menu and select “Change Purge Fluid Bag.” Follow the instructions on the screen. (Refer to “Purge Cassette Procedures” earlier in this section of the manual.)
3. If the pressure stabilizes, no other action is required.
If the purge pressure is not stable, proceed to Step 4.
4. If the Purge Pressure Low alarm remains unresolved for more than 20 minutes, there may be a problem with the purge cassette. Replace the purge cassette. (Refer to “Change Cassette and Bag” instructions on the previous page.)

PURGE SYSTEM OPEN



If at anytime during the course of support with the Impella RP[®] System Catheter, the Automated Impella Controller alarms “Purge System Open,” follow the instructions below.

1. Inspect the purge system for leaks.
2. If no leaks are visible, there may be a problem with the purge cassette. Replace the purge cassette. (Refer to instructions earlier in this section of the manual.)

PURGE PRESSURE HIGH AND PURGE SYSTEM BLOCKED

If the purge pressure exceeds 1100 mmHg, the Automated Impella Controller displays the “Purge Pressure High” alarm. If the purge flow stops completely, the controller displays the “Purge System Blocked” alarm. For either event, follow these steps:

1. Inspect the purge system and check the Impella RP System Catheter for kinks in the tubing.
2. Check the dextrose concentration of the purge fluid. Decrease the concentration to 5% if current concentration is higher
3. Replace the purge cassette using the “Change Cassette and Bag” procedure earlier in this section.
4. Monitor Motor Current.

Unresolved Purge Pressure High Alarm

If not resolved by the recommendations provided, high purge pressure—which triggers the “Purge Pressure High” alarm message—could be an indication of a kink in the Impella RP System Catheter. In this case, the motor is no longer being purged and may eventually stop. Monitor motor current and consider replacing the Impella RP System Catheter whenever a rise in motor current is seen.

PATIENT WEANING

Weaning the patient from the Impella RP System Catheter is at the discretion of the physician. Weaning may occur when right ventricular recovery is suspected and/or the patient is approaching the maximum duration of use for the Impella RP System Catheter. It should be initiated in a step-wise manner, such as described below.

The following weaning protocol is provided as guidance only.

1. Initiate the weaning process by temporarily reducing the Impella RP System Catheter flow to about 2 L/min.
2. Assess right ventricular function. Small changes in right ventricular systolic function as measured by echocardiography may be accompanied by significant improvement in right side forward flow; therefore, it is important to evaluate both echocardiographic evidence of improvement as well as CVP, flow rate, and overall perfusion.
3. Record available information regarding flow rate, CVP, echo parameters, and systemic hemodynamics.
4. After 15–20 minutes at the reduced flow rate, if there are signs of right ventricular recovery and no adverse effects from reduction in flow rate, continue the weaning process by reducing flow rate as tolerated to 0.5L/min (P-1). At this flow rate there will no longer be any forward flow across the right heart.
5. If the patient is maintained at a low flow rate (<1.5L/min) for a prolonged period, increase ACT to at least 250seconds.

Signs of Right Ventricular Recovery

As right-side support is slowly weaned, right ventricular recovery is indicated by preservation of the normal range of left-sided cardiac output as well as by a lack of severe elevation in CVP.

REMOVING THE IMPELLA RP® SYSTEM CATHETER

1. Wean the patient by following the steps in the previous section.
2. Leave the Impella RP System in the pulmonary artery at P-2 until ACT drops below 150
OR
Reduce the performance level to P-1, pull the catheter into the inferior vena cava (approximately 30 to 40 cm), and wait until ACT drops below 150.
3. When ACT is below 150 seconds and patient hemodynamics remain stable, decrease performance level to P-1, pull the catheter into the inferior vena cava if it is not already there, and stop the motor by reducing the performance level to P-0.
4. Remove initial mattress suture and place new mattress suture, but do not tie off.
5. Remove the Impella RP System Catheter.
6. Tie off mattress suture. Apply pressure until hemostasis is achieved.
7. Disconnect the connector cable from the Automated Impella Controller and turn the controller off by pressing the power switch on the side of the controller for 3 seconds.

Page intentionally left blank.

6 CLINICAL EXPERIENCE



STUDY DESIGNS	6.1
Impella RP System Pivotal Study and CAP Study	6.1
Exclusion Criteria	6.2
IMPELLA RP SYSTEM POST APPROVAL STUDY (PAS)	6.3
Inclusion Criteria	6.3
Follow-up Schedule (Same for Both Studies).....	6.3
Study Endpoints (Same for Both Studies)	6.3
Analysis	6.4
ACCOUNTABILITY OF COHORT	6.4
Study Population Demographics and Baseline Characteristics.....	6.5
SAFETY AND EFFECTIVENESS RESULTS	6.9
Primary Endpoint	6.9
Secondary Endpoints.....	6.9
OTHER RESULTS	6.12
Procedural Parameters.....	6.12
Subgroup Analysis	6.12

SUMMARY OF PRIMARY CLINICAL STUDY

Abiomed has collected clinical data to establish a reasonable assurance of safety and effectiveness of the Impella RP System in patients who developed acute right heart failure or decompensation and required temporary (≤ 14 days) right heart support. The clinical data supporting the PMA approval were pooled from the following three data sets:

- Impella RP System pivotal study: 30 patients
- Impella RP System continued access protocol (CAP) study: 4 patients
- Impella RP System post-approval study (PAS): 26 patients A summary of these clinical studies is presented below.

STUDY DESIGNS

IMPELLA RP SYSTEM PIVOTAL STUDY AND CAP STUDY

The Impella RP System pivotal study (also known as the “RECOVER RIGHT” study) and the Impella RP System CAP study had the same study design and were prospective, multi-center, non-randomized studies conducted under investigational device exemption (IDE) G120159. Patients in these two studies were treated between March 22, 2013 and January 19, 2015 at 9 investigational sites in the U.S.

The studies consisted of the following two cohorts:

- Cohort A: Patients who develop right heart failure within 48 hours post-implantation of an FDA approved implantable surgical left ventricular assist device (LVAD).
- Cohort B: Patients who developed cardiogenic shock involving right heart failure or dysfunction post cardiotomy within 48 hours post surgery or post myocardial infarction.

INCLUSION CRITERIA

The study population consisted of consented patients (≥ 18 years of age) who developed RVF either a) during or after durable LVAD implantation (Cohort A) or b) subsequent to post-cardiotomy cardiogenic shock or post myocardial infarction (Cohort B).

RVF was defined as:

- $ACI < 2.2 \text{ l/min/m}^2$ despite continuous infusion of high dose of inotropes and any of the following:
 - $CVP > 15 \text{ mmHg}$ or
 - $CVP/PCWP$ or $LAP > 0.63$ or
 - Moderate to severe global RV dysfunction on echocardiography defined as one of the following criteria: global RV hypokinesis, a TAPSE score of $\leq 14 \text{ mm}$, right ventricular diameter at base $> 42 \text{ mm}$, right ventricular short axis (or mid cavity) diameter $> 35 \text{ mm}$)
- High dose of inotropes was defined as Dobutamine of $\geq 10 \mu\text{g/kg/min}$ or equivalent for more than 15 minutes (120 minutes for milrinone) and/or administration of more than one inotrope/vasopressor medication

EXCLUSION CRITERIA

Specific to Cohort A:

1. INTERMACS 1 patients (Critical cardiogenic shock patient who is “crashing and burning,” has life-threatening hypotension and rapidly escalating inotropic or pressor support, with critical organ hypoperfusion often confirmed by worsening acidosis and lactate levels)
2. End organ failure (defined as hepatic total bilirubin ≥ 5 mg/dL based on lab data within 24 hours prior to Impella RP System initiation, renal: creatinine ≥ 4 mg/dL based on lab data within the 24 hours prior to Impella RP System initiation)
3. Evidence of acute neurologic injury following LVAD implant

Specific to Cohort B:

1. Patient in profound cardiogenic shock defined as systolic blood pressure < 75 mmHg and CI < 1.3 l/min/m² despite 2 or more high dose of inotropes \pm mechanical support or evidence of shock-related end-organ damage, metabolic acidosis (pH 7.1 or less) and not corrected by 100 ml NaHCO₃ (1mEq/ml), disseminated intravascular coagulation or clinical evidence of diffuse brain injury or in cardiogenic shock for > 24 hours.
2. AMI with mechanical complications (ventricular septal defect, myocardial rupture, papillary muscle rupture)
3. Unsuccessful revascularization of the RCA (TIMI 0.1 post PCI or post-CABG)

General – For Both Cohorts

1. Active infection, two of the following WBC $> 12,500$, positive blood culture, fever
2. RA, RV and/or PA thrombus
3. Prosthetic valves in the right heart (tricuspid or pulmonary valves)
4. Unrepaired atrial septal defect/ patent foramen ovale
5. Structural tricuspid valve disease
6. Severe pulmonary valve stenosis or insufficiency
7. Intolerance to anticoagulant or antiplatelet therapies
8. Severe pulmonary hypertension (PAP > 60 mmHg)
9. Documented DVT and/or presence of IVC filter
10. Anatomic conditions precluding insertion of the pump or safe use of the device such as severe anomaly of the inferior vena cava, calcification or other disorders of the pulmonary artery wall
11. Pulmonary artery conduit replacement
12. Patient on right side support device or extracorporeal membrane oxygenation
13. Current diagnosis of pulmonary embolism
14. Patient with anatomic anomalies or aortic diseases like aortic dissection, Marfan-Syndrome, Morbus Erdheim-Gsell or others
15. Allergy or intolerance to contrast media

16. Thrombolysis within the previous 30 days or known existing coagulopathy such as thrombocytopenia, heparin induced thrombocytopenia (HIT), hemoglobin diseases such as sickle cell anemia or thalassemia
17. Existing congenital heart disease precluding device insertion
18. Participation in any other clinical investigation that is likely to confound study results or affect study outcome

IMPELLA RP SYSTEM POST APPROVAL STUDY (PAS)

The Impella RP System PAS was a prospective, multi-center, non-randomized study conducted as a condition of approval for the original HDE. Patients in the study were treated in the commercial setting between May 27, 2015 and September 24, 2016 at 8 investigational sites in the U.S.

INCLUSION CRITERIA

Enrollment in the Impella RP System PAS was limited to patients who met the approved indication of the device under the HDE and who were not contraindicated.

FOLLOW-UP SCHEDULE (SAME FOR BOTH STUDIES)

All patients were scheduled to return for follow-up examinations at 30 and 180 days post device explant.

STUDY ENDPOINTS (SAME FOR BOTH STUDIES)

The primary endpoint was the survival rate at 30 days post device explant or hospital discharge (whichever is longer), or at induction of anesthesia for a longer term therapy, including heart transplant or implantation of a surgical right ventricular assist device (RVAD; as a bridge-to-recovery or bridge-to-transplant).

The secondary safety endpoints were determined by the rates of the following adverse events at 30 days or discharge (whichever is longer), or at induction of anesthesia for a longer term therapy:

- Major bleeding
- Hemolysis
- Pulmonary embolism
- Tricuspid/pulmonary valve dysfunction (defined as tricuspid/pulmonic valve injury resulting in increased valve regurgitation versus baseline)

The secondary effectiveness endpoints included the following:

- Central venous pressure (CVP) and cardiac index (CI) improvement post initiation of Impella RP System support
- Decreased use of inotropes during support
- Improvement in left ventricular assist device (LVAD) flow or left ventricle pumping function secondary to the increased venous return by the Impella RP System within 48 hours post implant

ANALYSIS

The three data sets listed above were pooled and analyzed descriptively. The success criterion was based on clinical judgment.

ACCOUNTABILITY OF COHORT

A total of 60 subjects were treated in the 3 prospective studies, including 31 subjects (52%) enrolled in Cohort A and 29 subjects (48%) enrolled in Cohort B, as shown in Figure 6.1.

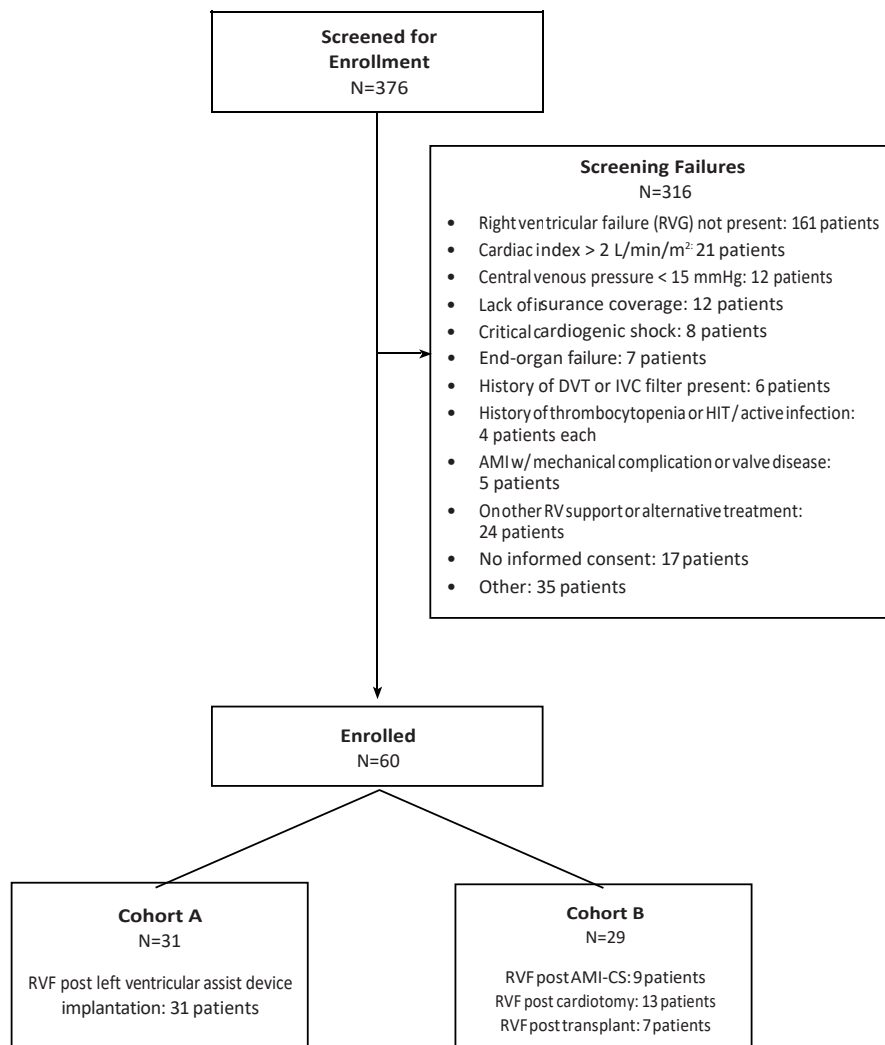

Figure 6.1 Study Flow Schematic

STUDY POPULATION DEMOGRAPHICS AND BASELINE CHARACTERISTICS

The patient baseline characteristics are summarized in Table 6.1. The overall age was 59±15 years old. Among all patients, 88.5% presented with congestive heart failure (CHF), 60% had history of arrhythmia, 57% had ICD or pacemaker implanted, 53% had diabetes, 37.5% had chronic kidney disease, and 20% had prior CVA. Of note, 60% of the patients had received blood products and 78.6% were in NYHA Class IV prior to device implant.

Table 6.1 Patient Characteristics

Patient Characteristics	Summary Statistics*		
	Chort A (N=31)	Cohort b (N=29)	All patients (N=60)
Age	54.5±14.9 (31)	62.9±14.3 (29)	58.6±15.1 (60)
Gender			
Male	80.6% (25/31)	55.2% (16/29)	68.3% (41/60)
Female	19.4% (6/31)	44.9% (13/29)	31.7% (19/60)
Race			
White	54.8% (17/31)	44.8% (13/29)	50.0% (30/60)
Black or African American	41.9% (13/31)	44.8% (13/29)	43.3% (26/60)
Asian	3.2% (1/31)	6.9% (2/29)	5.0% (3/60)
Body Surface Area (m²)	2.0±0.2 (31)	1.9±0.2 (29)	1.9±0.2 (60)
Hypertension	77.4% (24/31)	86.2% (25/29)	81.7% (49/60)
Coronary Artery Disease	60.0% (18/30)	57.1% (16/28)	58.6% (34/58)
Congenital Heart Disease	7.7% (2/26)	8.0% (2/25)	7.8% (4/51)
Congestive Heart Failure	96.8% (30/31)	66.7% (16/24)	83.6% (46/5)
New York Heart Association (NYHA) Classification			
I	0.0% (0/29)	5.0% (1/20)	2.0% (1/49)
II	3.4% (1/29)	5.0% (1/20)	4.1% (2/49)
III	10.3% (3/29)	15.0% (3/20)	12.2% (6/49)
IV	86.2% (25/29)	75.0% (15/20)	81.6% (40/49)
Myocardial Infarction	46.4% (13/28)	52.0% (13/25)	49.1% (26/53)
PCI	41.9% (13/31)	32.1% (9/28)	37.3% (22/59)
CABG	9.7% (3/31)	17.2% (5/29)	13.3% (8/60)
Arrhythmia	79.3% (23/29)	73.1% (19/26)	76.4% (42/55)
Cerebrovascular Accident	10.7% (3/28)	28.0% (7/25)	18.9% (10/53)
Stroke	7.1% (2/28)	4.0% (1/25)	5/7% (3/53)
TIA	0.0% (0/28)	24.0% (6/25)	11.3% (6/53)
Other	3.6% (1/28)	0.0% (0/25)	1.9% (1/53)
Smoking	46.7% (14/30)	51.7% (15/29)	49.2% (29/59)
Chronic Obstructive Pulmonary Disease	20.7% (6/29)	7.7% (2/26)	14.5% (8/55)
Diabetes	51.6% (16/31)	41.4% (12/29)	46.7% (28/60)
Chronic Kidney Disease	37.9% (11/29)	32.0% (8/25)	35.2% (19/54)
Valve Replacement/Repair	12.9% (4/31)	17.2% (5/29)	15.0% (9/60)
ICD/Pacemaker Implanted	64.5% (20/31)	24.1% (7/29)	45.0% (27/60)
LVEF (%)	13.8±6.0 (28)	46.5±5.9 (25)	29.2±20.2 (53)
TAPSE (mm)	13.9±6.5 (14)	11.7±4.8 (14)	12.8±5.7 (28)

* Categorical data: % (n/total no.): variable data: mean±SD (n)

The baseline laboratory parameters are provided in Table 6.2. Both kidney and liver functions were reflective of poor end-organ perfusion prior to device insertion.

Table 6.2 Baseline Laboratory Parameters

Baseline Characteristics	Summary Statistics*		
	Chort A (N=31)	Cohort b (N=29)	All patients (N=60)
White blood cell (WBC) count (10 ³)	12.1±6.8 (31)	14.4±9.5 (29)	13.2±8.2 (60)
Platelets count (10 ³)	208.1±92.3 (31)	230.4±133.4 (29)	218.9±113.6 (60)
Hemoglobin (g/dL)	10.1±2.0 (31)	10.9±2.0 (29)	10.5±2.0 (60)
Hematocrit (%) (N)	30.9±6.2 (31)	33.3±5.9 (29)	32.1±6.1 (60)
Plasma free hemoglobin (mg/dL)	13.6±11.8 (16)	39.0±59.1 (12)	24.5±40.8 (28)
Blood urea nitrogen (BUN; mg/dL)	27.3±17.2 (31)	31.5±16.6 (29)	29.4±16.9 (60)
Serum creatinine (mg/dL)	1.5±0.6 (31)	1.5±0.7 (29)	1.5±0.6 (60)
Creatinine clearance (mL/min)	76.8±55.1 (23)	68.9±55.2 (22)	73.0±54.7 (45)
Total bilirubin (mg/dL)	1.6±1.1 (29)	1.1±0.6 (29)	1.4±0.9 (58)
Lactate dehydrogenase (LDH; U/L)	539.5±345.9 (24)	715.0±553.6 (14)	604.1±435.2 (38)
* Mean±SD (n)			

WBC: White Blood Cells; BUN: Blood Urea Nitrogen; LDH: Lactate Dehydrogenase; BNP: B-type natriuretic peptide

The baseline support and hemodynamic characteristics are summarized in Table 6.3. All patients enrolled presented with right ventricular failure and poor hemodynamics at the time of implant, despite high dose of inotropes/pressors.

Table 6.3 Baseline Support and Hemodynamic Characteristics

Support and Hemodynamic Characteristics	Summary Statistics*		
	Chort A (N=31)	Cohort b (N=29)	All patients (N=60)
Number of inotropes/pressors (prior to device insertion)	3.6±.2 (31)	3.1±1.3 (28)	3.4±1.2 (59)
Hemodynamics (prior to device insertion)			
Cardiac index (L/min/m ²)	1.8±0.5 (31)	1.9±0.6 (28)	1.9±0.5 (59)
Cardiac output (L/min)	3.9±1.4 (31)	3.8±1.3 (28)	3.9±1.3 (59)
Pulmonary Capillary Wedge pressure/left arterial pressure (mmHg)	14.5±4.6 (8)	20.4±8.5 (8)	17.4±7.3 (16)
Right arterial pressure/central venous pressure (mmHg)	18.42±4.79 (31)	19.84±5.83 (29)	19.1±5.3 (60)
Pulmonary artery pressure: Systolic (mmHg)	39.4±12.1 (29)	39.8±10.3 (26)	39.6±11.1 (55)
Pulmonary artery pressure: Diastolic (mmHg)	23.9±11.6 (31)	21.2±7.8 (27)	22.5±9.9 (58)
Mean arterial Ppressure (mmHg)	75.6±12.4 (24)	65.9±16.3 (24)	70.7±15.1 (48)
Heart rate (BPM)	91.9±19.7 (28)	86.1±18.0 (28)	89.0±18.9 (56)
LVAD flow (L/min; Cohort A only)	4.0±0.7 (19)	N/A	4.0±0.7 (19)
* Mean±SD (n)			

SAFETY AND EFFECTIVENESS RESULTS

PRIMARY ENDPOINT

The primary endpoint of survival at 30 days or discharge post device removal (whichever is longer), or at induction of anesthesia for the next longer-term therapy (i.e., heart transplant or implantation of a surgical RVAD) was achieved in 73.3% of the patients, with 77.4% in cohort A and 69.0% in cohort B, as shown in Table 6.4. It is important to note that all patients discharged from the hospital (70% of all patients) recovered their right heart function and were discharged without any right ventricular mechanical support.

Table 6.4 Patient Survival Outcomes

Event	Summary Statistics*		
	Chort A (N=31)	Cohort b (N=29)	All patients (N=60)
Alive at 30 days/discharge/next therapy	77.4% (24/31)	69.0% (20/29)	73.3% (44/60)
Alive at next longer term therapy	16.1% (5/31)	6.9% (2/29)	11.7% (7/60)
Alive at 30 days	77.4% (24/31)	65.5% (19/29)	71.7% (43/60)
Alive at discharge	71.0% (22/31)	69.0% (20/29)	70.0% (42/60)
Right ventricle recovered (discharged without RVAD)	39.4±12.1 (29)	39.8±10.3 (26)	39.6±11.1 (55)
Mean arterial Ppressure (mmHg)	100% (22/22)	100% (20/20)	100% (42/42)
Heart rate (BPM)	75.6±12.4 (24)	65.9±16.3 (24)	70.7±15.1 (48)
LVAD flow (L/min; Cohort A only)	91.9±19.7 (28)	86.1±18.0 (28)	89.0±18.9 (56)
	4.0±0.7 (19)	N/A	4.0±0.7 (19)
*% (n/total no.)			

SECONDARY ENDPOINTS

Safety Endpoints

The secondary safety endpoint results are summarized in Table 6.5, which were measured at hospital discharge or to induction of anesthesia to a longer term therapy.

Table 6.5 Secondary Safety Endpoints Results

Event	Summary Statistics*		
	Chort A (N=31)	Cohort b (N=29)	All patients (N=60)
Major bleeding	54.8% (17/31)	41.4% (12/29)	48.3% (29/60)
Hemolysis	29.0% (9/31)	24.1% (7/29)	26.7% (16/60)
Pulmonary embolism	0.0% (0/31)	0.0% (0/29)	0.0% (0/60)
*% (n/total no.)			

Effectiveness Endpoints

Central venous pressure and cardiac index:

The central venous pressure and cardiac index changes over time are shown in Figures 6.2 and 6.3, respectively. The central venous pressure decreased from 19 ± 0.8 to 13 ± 1 mmHg post support; the cardiac index increased from 1.9 ± 0.1 to 3.1 ± 0.2 L/min/m² post support. In addition, both the central venous pressure and the cardiac index remained stable post-explant of the Impella RP System.

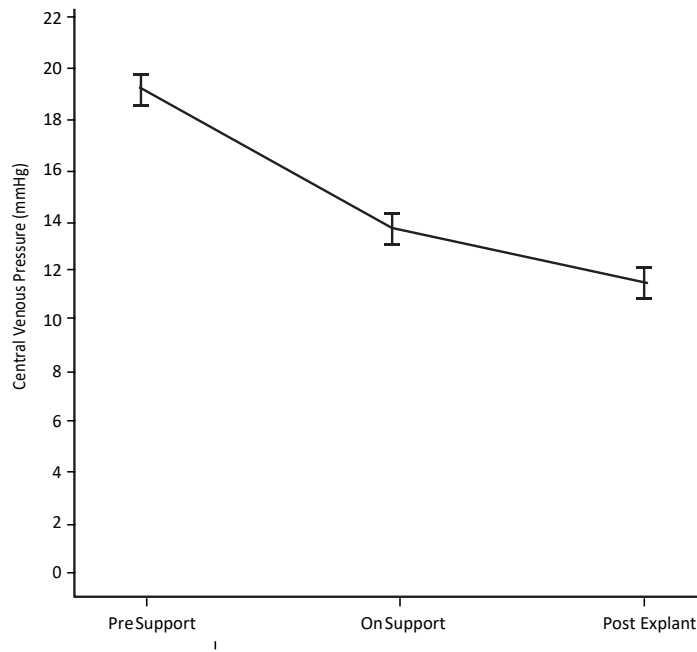

Figure 6.2: Central Venous Pressure Change Over Time

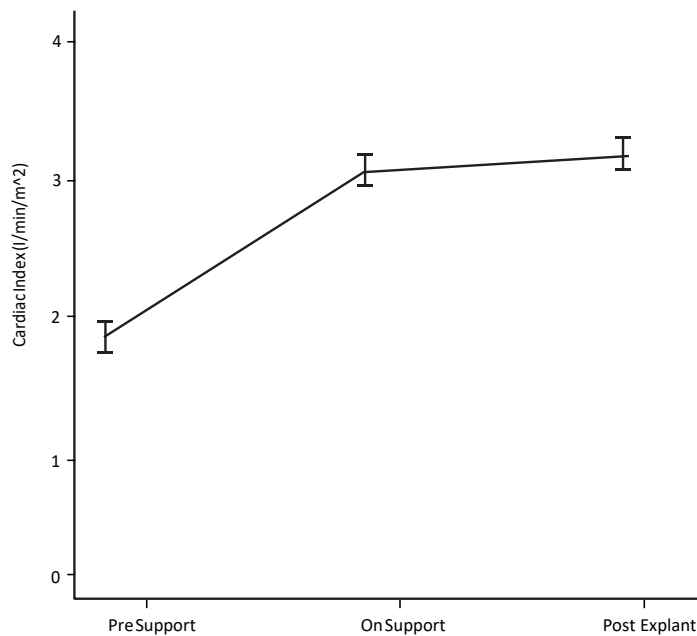

Figure 6.3: Cardiac Index Change Over Time

LVAD flow:

The LVAD flow in Cohort A patients is shown in Figure 6.4. The flow increased from 4.0 ± 0.2 L/min to 4.6 ± 0.1 L/min post support.

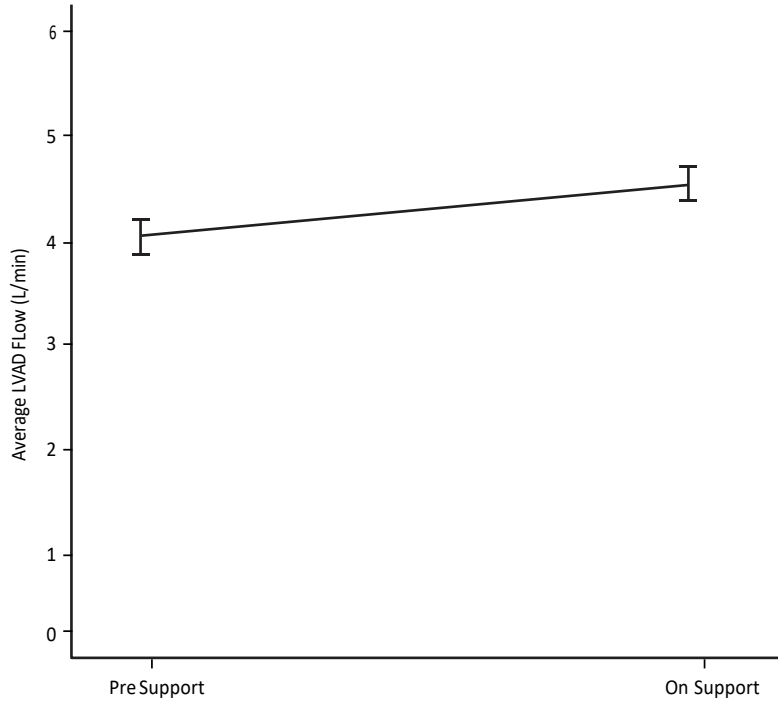

Figure 6.4: LVAD Flow Change from Baseline to On support

Inotrope and pressor uses during support:

The inotrope and pressor uses during support are shown in Figure 6.5. A rapid decrease of such uses were seen post initiation of Impella RP System support.

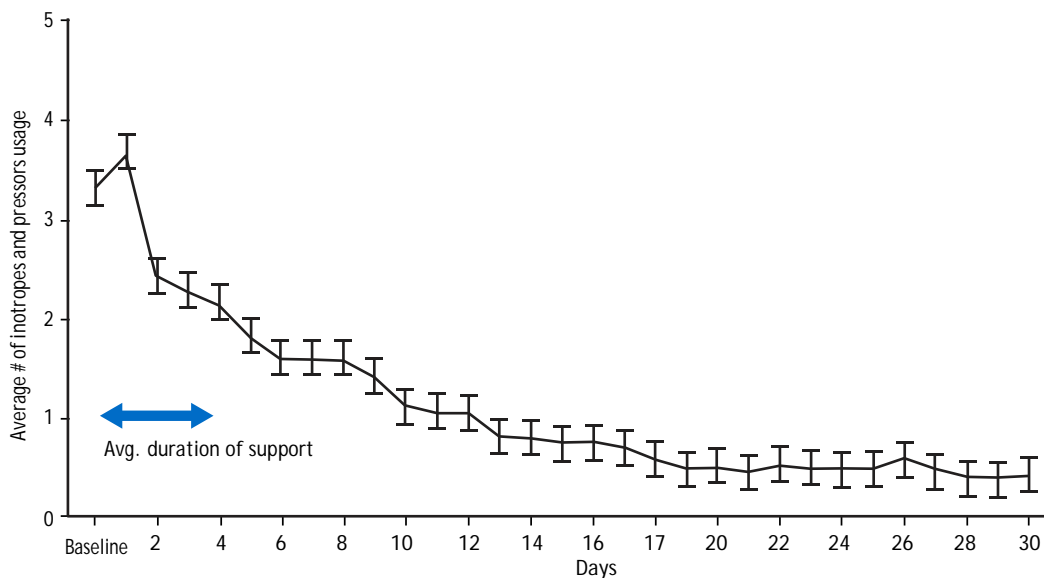

Figure 6.5: Inotrope and Pressor Uses during Support

OTHER RESULTS

PROCEDURAL PARAMETERS

The procedural parameters are summarized in Table 6.6.

Table 6.6: Procedural Parameters

Procedural Parameters	Summary Statistics*		
	Chort A (N=31)	Cohort b (N=29)	All patients (N=60)
Side of implantation			
Left femoral vein	0.0% (0/31)	6.9% (2/29)	3.3% (2/60)
Right femoral vein	100.0% (31/31)	93.1% (27/29)	96.7% (58/60)
Estimated blood loss during introducer insertion			
<25 mL	86.4% (19/22)	88.5% (23/26)	87.5% (42/48)
25-50 mL	9.1% (2/22)	7.7% (2/26)	8.3% (4/48)
>100 mL	4.5% (1/22)	3.8% (1/26)	4.2% (2/48)
Estimated blood loss during catheter placement			
<25mL	66.7% (14/21)	46.2% (12/26)	55.3% (26/47)
25-50 mL	28.6% (6/21)	38.5% (10/26)	34.0% (16/47)
>100 mL	4.8% (1/21)	7.7% (2/26)	6.4% (3/47)
Duration of support (hours)	101.2±66.0 (21)	81.9±49.1 (29)	90.0±57.0 (50)
Average device flow (L/min)	3.2±0.4 (23)	3.2±0.4 (27)	3.2±0.4 (50)
Categorical data: % (n/total no.); variable data: mean±SD (n)			

SUBGROUP ANALYSIS

Gender Analysis

The outcomes by gender were also examined. A trend towards higher mortality was observed in female patients; the rate of the other adverse events appeared comparable between genders. However, the small sample size and the multiple cohorts studied prevent any conclusions based on gender.

7 AUTOMATED IMPELLA CONTROLLER ALARMS



- ALARMS OVERVIEW..... 7.1**
 - Alarm Levels 7.1
 - Alarm Display 7.2
 - Mute Alarm Function 7.2
- ALARM MESSAGE SUMMARY 7.3**

ALARMS OVERVIEW

The Automated Impella Controller monitors various functions to determine whether specific operational parameters are within expected limits. When a parameter goes outside of its specified limits, the Automated Impella Controller sounds an alarm tone and displays an alarm message that can be viewed on the display screen on the front of the controller. The alarm tone indicates the severity of the alarm. The alarm message on the display screen is color-coded for severity and provides details on the cause of the alarm and how to resolve the alarm. After muting an alarm, if another alarm occurs it will only be heard and displayed if it is a higher priority alarm than the one that was muted.

ALARM LEVELS

Alarms are divided into three levels of severity:

- Advisory (white)
- Serious (yellow)
- Critical (red)

Table 7.1 Alarm Levels

Category	Description	Audible Indicator*	Visual Indicator
Advisory	Notification	1 beep every 5 minutes	Alarm header on white background
Serious	Abnormal situation. Prompt action needed.	3 beeps every 15 seconds	Alarm header on yellow background
Critical	High priority. Immediate action needed.	10 beeps every 6.7 seconds	Alarm header on red background

* Sound pressure of audible alarm indicators is >80 dBA

For some alarms, there is a short delay between the triggered event and the audible annunciation and visual display of the alarm. (For more information, refer to the “Alarm Delay Information” discussion in section 8 of this manual.)

ALARM DISPLAY

The alarm window is located in the upper left region of the display screen on the front of the Automated Impella Controller (see Figure 7.1). Alarms are listed in order of priority, with the highest priority alarm at the top. Up to three alarms may be displayed at one time. The colored background behind the highest priority alarm will alternate between two shades of that color. The white panel displayed to the right of the alarm header contains instructions for resolving the alarm condition. The instructions should be followed in the order given.

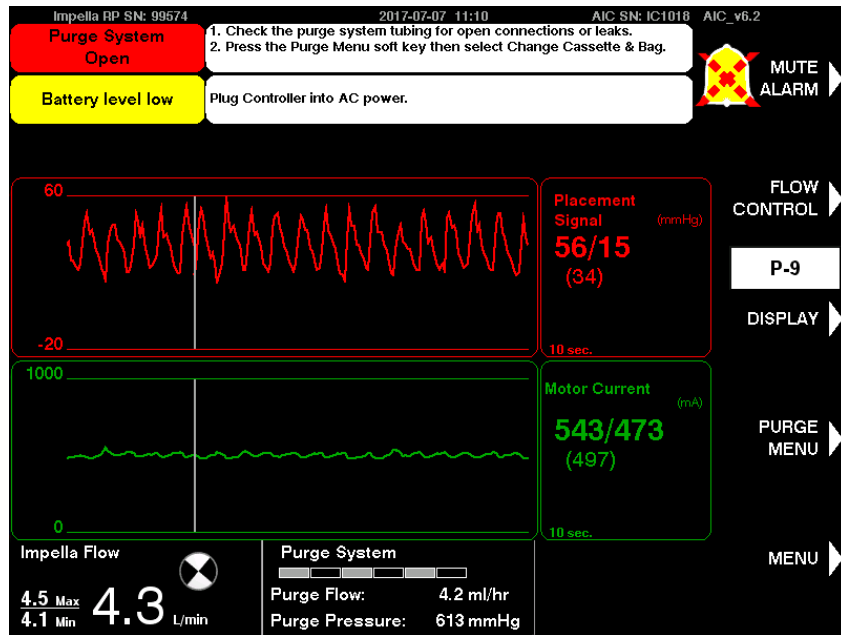

Figure 7.1 Alarm Window

Alarms That Resolve On Their Own

The audible indicator will shut off if an alarm condition is resolved before you press **MUTE ALARM**. The visual message, however, will continue to be displayed, with the alarm header on a gray background, for 20 minutes or until you press **MUTE ALARM**. This allows you to identify the alarm that occurred.

MUTE ALARM FUNCTION

Pressing the **MUTE ALARM** button on the upper right of the Automated Impella Controller display screen will silence the audible alarm indicator for 2 minutes (for red or yellow alarms) or 5 minutes (for white advisory alarms). When an alarm is silenced, the words “MUTE ALARM” next to the button are replaced by the mute alarm indicator, a crossed-out bell icon (as shown in Figure 7.1).

ALARM HISTORY SCREEN

The alarm history screen may be accessed through the **MENU**. This screen contains a log of the alarms that occurred during the case. This log is maintained when the Automated Impella Controller is powered down or after a power failure. The controller does, however, maintain a long-term log that is saved after the Automated Impella Controller is powered down or after a power failure and this information may be downloaded by Abiomed personnel.

ALARM MESSAGE SUMMARY

Table 7.2 briefly describes all of the alarm messages that may appear on the Automated Impella ControllerAutomated Impella Controller when used with the Impella RP® System Catheter.

Table 7.2 Automated Impella Controller Alarm Messages

Severity	Alarm Header	Action	Cause
Critical Alarms	Air in Purge System	The purge system has stopped. Press the PURGE MENU soft key then select De-Air Purge System.	There is air in the purge tubing.
	Battery Critically Low	Plug controller into AC power.	Battery power has 15% remaining capacity.
	Battery Failure	Plug controller into AC power.	One of the batteries has failed.
	Battery Failure	<ol style="list-style-type: none"> 1. Plug controller into AC power. 2. Press switch located on the underside of the controller. 3. Switch to backup controller. 	A battery switch is turned off or there is a malfunction of the switch.
	Battery Temperature High	Switch to backup controller.	Battery temperature is greater than 60°C.
	Complete Procedure	<ol style="list-style-type: none"> 1. Follow the steps on the screen or 2. Exit the procedure 	The Complete Procedure serious alarm (yellow; see next page) is active and the user has not responded for an additional 2 minutes.
	Controller Failure	The purge system has stopped. Switch to backup controller.	The controller has detected a purge pressure sensor defect and has stopped the purge system.
	Controller Failure	Switch to backup controller.	There is a problem with the controller electronics.
	Emergency Shutdown Imminent	Release ON/OFF push button.	Power switch pressed for 15 seconds while Impella RP System Catheter still connected.
	Impella Disconnected	<ol style="list-style-type: none"> 1. Check cable connection to console. 2. Check Impella connection to cable. 	Running Impella RP System Catheter disconnected.
	Impella Failure	Replace Impella.	There is a problem with the Impella RP System Catheter motor.
	Impella Stopped	<ol style="list-style-type: none"> 1. Replace white connector cable. 2. Switch to backup controller. 3. Replace Impella pump. 	There is a problem with the electronics.

Table 7.2 Automated Impella Controller Alarm Messages (continued)

Severity	Alarm Header	Action	Cause
Critical Alarms	Impella Stopped	<ol style="list-style-type: none"> 1. Restart Impella. 2. Replace Impella after 3rd unsuccessful restart attempt 	There may be a mechanical or electrical problem in the Impella RP System Catheter.
	Impella Stopped Controller Failure	Switch to backup controller.	There is a problem with the controller electronics.
	Impella Stopped Motor Current High	<ol style="list-style-type: none"> 1. Restart Impella. 2. Replace Impella after 3rd unsuccessful restart attempt. 	There is a problem with the Impella RP® System Catheter motor.
	Impella Stopped Retrograde Flow	To prevent retrograde flow, restart Impella or withdraw pump from ventricle.	Impella RP System Catheter is not running; possible retrograde flow through Impella RP System Catheter.
	Purge Disc Not Detected	Re-insert Purge Disc	The controller is not detecting that the purge disc is clicked into the front of the controller.
	Purge Pressure High	Decrease concentration of dextrose in the purge solution.	Purge pressure is ≥ 1100 mmHg with the purge flow < 2 mL/hr.
	Purge Pressure Low	<ol style="list-style-type: none"> 1. Check purge system tubing for leaks. 2. Increase concentration of dextrose in the purge solution. 3. Replace purge cassette. 	Purge pressure has dropped below 300 mmHg with the purge flow 30 mL/hr for 30 seconds or longer.
	Purge System Blocked	<ol style="list-style-type: none"> 1. Check all purge system tubing for kinks or blockages. 2. Decrease concentration of dextrose in the purge solution. 	<p>Purge flow has dropped below 1 mL/hr.</p> <p>Kinked or blocked purge connecting tube.</p> <p>Kinked or blocked purge lumen in Impella RP System Catheter.</p>
	Purge System Failure	<ol style="list-style-type: none"> 1. Replace purge cassette. 2. Switch to backup controller. 	There is a problem with the purge cassette or the purge unit driver.
	Purge System Open	<ol style="list-style-type: none"> 1. Check the purge system tubing for open connections or leaks. 2. Replace purge cassette. 	Purge pressure has dropped below 100 mmHg for 20 seconds or longer.
Retrograde Flow	Check for high afterload pressure.	Reverse flow detected at high motor speed.	

Table 7.2 Automated Impella Controller Alarm Messages (continued)

Severity	Alarm Header	Action	Cause
Serious Alarms	Battery Comm. Failure	Plug controller into AC power.	Loss of communication to the battery.
	Battery Level Low	Plug controller into AC power.	Battery power has 50% remaining capacity.
	Battery Temperature High	<ol style="list-style-type: none"> 1. Check controller for blocked air vents. 2. Switch to backup controller. 	Battery temperature is greater than 50°C and less than or equal to 60°C.
	Complete Procedure	<ol style="list-style-type: none"> 1. Follow the steps on the screen or 2. Exit the procedure 	User has not responded to a de-air or purge procedure screen for more than 1 minute or a transfer to standard configuration screen for more than 5 minutes.
	Controller Error	Switch to backup controller.	There is a problem with the controller electronics.
	Impella Catheter Not Supported	<ol style="list-style-type: none"> 1. Replace Impella with supported catheter (2.5, CP, 5.0, LD, RP). 2. Contact Abiomed Service to upgrade Impella Controller. 	The Impella Catheter is not supported to operate with the current version of controller software and/or hardware.
	Impella Defective	Do not use Impella. Replace Impella.	There is a problem with the Impella RP® System Catheter electronics.
	Impella Stopped Controller Failure	Locate Back-up Controller	Attempting to restart catheter. Catheter expected to start within 30 seconds.
	Placement Signal Not Reliable	Monitor patient hemodynamics.	There is a problem with the Impella Catheter sensor signal.
	Purge Cassette Failure	Replace purge cassette.	There is a problem with the purge cassette software.
	Purge Volume Critically Low	<ol style="list-style-type: none"> 1. Open PURGE MENU and select Change Purge Fluid Bag. 2. Follow the instructions to change the purge fluid. 	There are 15 mL (in addition to 5% of the starting bag volume) or fewer remaining in the purge fluid bag.
Reinstall Software	Software installation was unsuccessful.	Reinstall software. Software was not installed successfully.	
Suction	<ol style="list-style-type: none"> 1. Check filling and volume status. 2. Check Impella position. 3. Reduce P-Level. 	Suction is detected.	

Table 7.2 Automated Impella Controller Alarm Messages (continued)

Severity	Alarm Header	Action	Cause
Advisory Alarms	AC Power Disconnected	Controller is running on battery power.	AC power was disconnected.
	Audio Off	The audio for the following alarms has been disabled. <Alarms will be listed here>	User has disabled audio for one or more of the following alarms: <ul style="list-style-type: none"> • Purge Pressure High • Purge System Blocked • Suction • Placement Signal Not Reliable
	Preventing Retrograde Flow	Impella P-level has increased to prevent retrograde flow. <ol style="list-style-type: none"> 1. Consider increasing target P-level. 2. For weaning, disable Retrograde Flow Control through MENU soft key. 	Retrograde flow has been detected and minimum motor speed has been increased to more than target P-level.
	Purge Cassette Incompatible	Contact Abiomed Service to update Impella Controller.	Incompatible purge cassette RFID version.
	Purge Flow Decreased	The purge flow has decreased by 2.5 mL/hr or more. This is a notification only; no action is required.	Purge flow has decreased by ≥ 2.5 mL/hr.
	Purge Flow Increased	The purge flow has increased by 2.5 mL/hr or more. This is a notification only; no action is required.	Purge flow has increased by ≥ 2.5 mL/hr.
	Purge Volume Low	<ol style="list-style-type: none"> 1. Open PURGE MENU and select Change Purge Fluid Bag. 2. Follow the instructions to change the purge fluid. 	There are 30 mL (in addition to 5% of the starting bag volume) or fewer remaining in the purge fluid bag.
	Surgical Mode Enabled	Impella pump stopped. Purge system running. 'Impella Stopped' alarm disabled. To exit this mode, start Impella pump.	Surgical Mode has been enabled to silence 'Impella Stopped' alarm at P-O.
	Unexpected Controller Shutdown	Switch to back-up Controller if condition persists.	Unexpected restart of controller due to software or hardware failures

8 GENERAL SYSTEM INFORMATION



TERMINOLOGY, ABBREVIATIONS, AND SYMBOLS	8.1
AUTOMATED IMPELLA CONTROLLER MECHANICAL SPECIFICATIONS	8.3
AUTOMATED IMPELLA CONTROLLER ELECTRICAL SPECIFICATIONS	8.3
EQUIPMENT DESIGN	8.4
EQUIPMENT CLASSIFICATIONS	8.4
FEDERAL COMMUNICATIONS COMMISSION (FCC) NOTICE	8.5
ELECTROMAGNETIC COMPATIBILITY	8.5
TRANSPORT BETWEEN HOSPITALS	8.11
Guidelines for Patient Transport	8.11
Important Transport Considerations	8.11
FAA Advisory	8.12
TRANSPORT WITHIN THE HOSPITAL.....	8.12
VGA MONITOR CONNECTION.....	8.13
ALARM DELAY INFORMATION	8.13
PATIENT ENVIRONMENT	8.14
USE ENVIRONMENT	8.14
WHITE CONNECTOR CABLE	8.14
IMPELLA RP SYSTEM CATHETER PARAMETERS.....	8.15
CLEANING.....	8.16
STORING THE AUTOMATED IMPELLA CONTROLLER	8.16
RETURNING AN IMPELLA RP SYSTEM CATHETER TO ABIOMED (UNITED STATES)	8.16

TERMINOLOGY, ABBREVIATIONS, AND SYMBOLS

Table 8.1 Terminology and Abbreviations

Catheter serial number	Identification number of the Impella RP System Catheter; stated on the package label, on the blue Impella plug, and the Automated Impella Controller display screen
Dextrose and Glucose	The terms “dextrose” and “glucose” are used interchangeably to refer to the solution used as purge fluid for the Impella RP System
Hz	Hertz
Motor housing	Enclosure of the Impella RP System Catheter motor
Pump	Central delivery unit of the Impella RP System Catheter, consisting of the motor, motor housing, cannula with inlet and outlet, and pigtail at the tip
Purge pressure	Pressure present in the Impella RP System Catheter and in the infusion line
Purge system	Impella purge cassette used for rinsing the Impella RP System Catheter
Retrograde flow	Reverse flow through the cannula when the Impella RP System Catheter is at a standstill (eg, regurgitation)
V	Volt
VA	Volt ampere (Watt)

Table 8.2 Symbols























	Caution; follow instructions for use
	Defibrillator-proof type CF equipment
	Keep dry
	Storage temperature (eg, 10°C to 30°C)
	Declares conformity with directive 93/42/EEC for medical devices
	Date of manufacture (eg, October 1, 2014)
	Protect from sunlight
	Symbol for lot designation; the manufacturer’s lot designation must be stated after the LOT symbol

Table 8.2 Symbols (continued)

REF 123456	Abiomed part number (eg, part number 123456)
SN 123456	Manufacturer's serial number (eg, serial number 123456)
Non Sterile!	The product is not sterile
 2016-06-01	Use-by date (eg, use before June 1, 2016)
	Do not reuse
	Sterilized using ethylene oxide
	Electric scrap; must be disposed of separately. Must not be disposed of as domestic waste.
	Protective Earth
	ON / OFF
	Alternating current (AC) only
	Equipotentiality
	Fuse
	Non-ionizing electromagnetic radiation
	USB port
	CAT 5 Port (Ethernet)
	MR Unsafe
	Do Not Flush
 Glucose	Glucose

AUTOMATED IMPELLA CONTROLLER MECHANICAL SPECIFICATIONS

Table 8.3 Mechanical specifications for the Automated Impella Controller

Parameter	Specification
Temperature	Operating: 10°C to 40°C (50°F to 104°F)
	Storage: -15°C to 50°C (5°F to 122°F)
Relative Humidity	Operating: 95%
	Storage: 95%
Atmospheric Pressure	Operating: 8000 ft (750 hPa) to -1000 ft (1050 hPa)
	Storage: 18,000 ft (500 hPa) to -1000 ft (1050 hPa)
Dimensions	Height: 351 mm (13.8 in)
	Width: 443 mm (17.4 in)
	Depth: 236 mm (9.3 in)
Dimensions – Packaged	Height: 508 mm (20.0 in)
	Width: 559 mm (22.0 in)
	Depth: 406 mm (15.0 in)
Weight	Maximum: 11.8 kg (26.1 lbs)
Weight – Packaged	Maximum: 13.6 kg (30 lbs)
Maintenance and repair interval	12 months (Work must be performed by technicians authorized by Abiomed)

AUTOMATED IMPELLA CONTROLLER ELECTRICAL SPECIFICATIONS

Table 8.4 Electrical specifications for the Automated Impella Controller

AC operation	100-230 V AC (nominal); 47-63 Hz; 1.1 A
Internal battery operation	14.4 V DC (nominal); lithium ion
Characteristic values	
Max. power consumption under load	120 VA
9.7 fuses	2 Amp. 250 V. 5 mm x 20 mm, slow-blow fuses
Running time without AC power with fully charged batteries	At least 60 minutes (charging duration of at least 5 hours)
Electrical system	Installation in accordance with pertinent regulations is required for use in medical facilities (eg, IEC stipulations).

EQUIPMENT DESIGN

The Automated Impella Controller conforms to the applicable requirements of the following standards:

- IEC60601-1:2012 Edition 3.1 *Medical Electrical Equipment Part 1: General Requirements for Basic Safety and Essential Performance*
- CSA C22.2#60601-1(2014) Ed:3 *Medical Electrical Equipment Part 1: General Requirements for Basic Safety and Essential Performance*
- AAMI ES60601-1:2005+C1:A2 *Medical Electrical Equipment Part 1: General Requirements for Basic Safety and Essential Performance*
- IEC60601-1-2:2014 Edition 4, *Medical Electrical Equipment – Part 1-2: General Requirements for Basic Safety and Essential Performance – Collateral Standard: Electromagnetic Disturbances – Requirements and Tests*
- IEC60601-1-6:2010, AMD1:2013 *Medical Electrical Equipment – Part 1-6: General Requirements for Safety – Collateral Standard: Usability*
- IEC60601-1-8:2006, AM1:2012 *Medical Electrical Equipment – Part 1-8: General Requirements for Safety – Collateral Standard: General Requirements, Tests and Guidance for Alarm Systems in Medical Electrical Equipment and Medical Electrical Systems*
- IEC 62304:2015 *Medical Device Software - Software Life-cycle processes*
- RTCA DO160G *Environmental Conditions and Test Procedures for Airborne Equipment*
- AIM 7351731 *Medical Electrical Equipment and System Electromagnetic Immunity test for Exposure to Radio Frequency Identification Readers*

EQUIPMENT CLASSIFICATIONS

Table 8.5 Equipment classifications

Type of protection against electric shock	IEC60601-1: Class I degree of protection: CF defibrillation-proof and internally powered. Relies not only on basic insulation against shock but also includes additional protection. Accomplished by providing means for connecting the equipment to the protective earth conductor of the fixed wiring of the installation in a way that prevents accessible metal parts from becoming live if basic insulation fails.
Degree of protection against electric shock for Automated Impella Controller	Class I Equipment
Mode of operation	Continuous
Degree of protection against explosion hazard	Not suitable for use in the presence of a flammable anesthetic mixture with air or with oxygen or nitrous oxide. Also not suitable for use in an oxygen-enriched atmosphere.
Degree of protection against harmful ingress of water	IEC 60529: IPX1 protected against dripping water.

FEDERAL COMMUNICATIONS COMMISSION (FCC) NOTICE

This device complies with Part 15 of the FCC Rules. Operation is subject to the following two conditions:

1. This device may not cause harmful interference.
2. This device must accept any interference received, including interference that may cause undesired operation.

Changes or modifications not expressly approved by Abiomed, Inc. could void the user's authority to operate this device.

NOTE: "Harmful interference" is defined by the FCC as follows: Any emission, radiation or induction that endangers the functioning of a radio navigation service or of other safety services or seriously degrades, obstructs or repeatedly interrupts a radiocommunications service operating in accordance with FCC rules.

ELECTROMAGNETIC COMPATIBILITY



Medical electrical equipment needs special precautions regarding EMC and needs to be installed and put into service according to the electromagnetic compatibility (EMC) information provided in this document.



Portable and mobile RF communications equipment can affect medical electrical equipment.



The equipment or system should not be used adjacent to or stacked with other equipment. If adjacent or stacked use is necessary, the equipment or system should be observed to verify normal operation in the configuration in which it will be used.



Use of cables, other than those sold by Abiomed, may result in increased emissions or decreased immunity of the Automated Impella Controller.



The Automated Impella Controller uses RFID (radio frequency identification) to identify and communicate with the purge cassette. Other equipment may interfere with the Automated Impella Controller even if that other equipment complies with CISPR emission requirements.



The Automated Impella Controller (AIC) performs as intended when exposed to radiofrequency (RF) disturbances below 20V/m. During transport, the AIC may be exposed to RF disturbances above 20 V/m, which could cause minor problems, such as intermittent displays of soft button menu selections, which have no effect on the operating parameters of the Impella support system, and will resolve readily once the disturbance ends. It could also potentially result in loss of support. Patients must be closely monitored at all times during transport.



Do not transport an Impella patient via commercial aircraft. Loss of support may occur aboard a commercial aircraft due to exposure to radiofrequency (RF) disturbances above the compliance level (<20V/m) of the Automated Impella Controller.

NOTE: The EMC tables and other guidelines that are included in this manual provide information to the customer or user that is essential in determining the suitability of the equipment or system for the electromagnetic environment of use, and in managing the electromagnetic environment of use permit the equipment or system to perform to its intended use without disturbing other equipment and systems or non-medical electrical equipment. For the electromagnetic testing (detailed in the following tables), the AIC Essential Performance was specified as: during the entire test period, the AIC continues to provide support to the patient.

Table 8.6 Guidance and manufacturer’s declaration - emissions, all equipment and systems

The Automated Impella Controller is intended for use in the electromagnetic environment specified below. The customer or user of the Automated Impella Controller should ensure that it is used in such an environment.		
Emissions Test	Compliance	Electromagnetic Enforcement – Guidance
RF Emissions CISPR 11	Group 1 Class A	The Automated Impella Controller uses RF energy only for its internal function. Therefore, its RF emissions are very low and are not likely to cause any interference in nearby electronic equipment.
	Class A	The Automated Impella Controller is suitable for use in all locations other than those located in residential environments and those directly connected to a low voltage power supply network which supplies buildings used for domestic purposes.
Harmonics IEC 61000-3-2	Class A	
Flicker IEC 61000-3-3	Complies	

NOTE: The EMISSIONS characteristics of this equipment make it suitable for use in industrial areas and hospitals (CISPR 11 class A). If it is used in a residential environment (for which CISPR 11 class B is normally required) this equipment might not offer adequate protection to radio-frequency communication services. The user might need to take mitigation measures, such as relocating or re-orienting the equipment.

Table 8.7 Guidance and manufacturer's Declaration - Immunity

The Automated Impella Controller is intended for use in the electromagnetic environment specified below. The customer or user of the Automated Impella Controller should ensure that it is used in such an environment.

Immunity Test	IEC 60601 Test Level	Compliance Level	Electromagnetic Environment – Guidance
Electrostatic Discharge (ESD) IEC 61000-4-2	±8 kV contact ±15 kV air	±8 kV contact ±15 kV air	Floors should be wood, concrete, or ceramic tile. If floors are synthetic, the relative humidity should be at least 30%.
Electrical Fast Transient/burst IEC 61000-4-4	±2 kV Mains ±1 kV for input/output lines	±2 kV Mains ±1 kV for input/output lines	Mains power quality should be that of a typical commercial or hospital environment.
Surge IEC 61000-4-5	±1 kV Differential ±2 kV Common	±1 kV Differential ±2 kV Common	Mains power quality should be that of a typical commercial or hospital environment.
Voltage dips, short interruptions and voltage variations on power supply input lines IEC 61000-4-11	> 95% dip for 0.5 cycle 60% dip for 5 cycles 30% dip for 25 cycles > 95% dip for 5 seconds	> 95% dip for 0.5 cycle 60% dip for 5 cycles 30% dip for 25 cycles > 95% dip for 5 seconds	Mains power quality should be that of a typical commercial or hospital environment. If the user of the Automated Impella Controller requires continued operation during power mains interruptions, it is recommended that the Automated Impella Controller be powered from an uninterruptible power supply or battery.
Power Frequency 50/60 Hz Magnetic Field IEC 61000-4-8	30 A/m	30 A/m	Power frequency magnetic fields should be that of a typical location in a typical commercial or hospital environment.

Table 8.8 Guidance and manufacturer’s declaration - emissions, equipment and systems that are life-supporting

The Automated Impella Controller is intended for use in the electromagnetic environment specified below. The customer or user of the Automated Impella Controller should ensure that it is used in such an environment.

Immunity Test	IEC 60601	Compliance	Electromagnetic Environment – Guidance
			Portable and mobile RF communications equipment should be separated from the Automated Impella Controller by no less than the recommended separation distances calculated/listed below:
Conducted RF IEC 61000-4-6	10 Vrms 150 kHz to 80 MHz	10 Vrms	$d = 0.35\sqrt{P}$
Radiated RF IEC 61000-4-3	10 V/m 80 MHz to 2.5 GHz	20 V/m	$d = 0.6\sqrt{P}$ 80 to 800 MHz $d = 1.2\sqrt{P}$ 800 MHz to 2.5 GHz Where P is the maximum power rating in watts and d is the recommended separation distance in meters. Field strengths from fixed transmitters, as determined by an electromagnetic site survey ^(a) , should be less than the compliance level in each frequency range. ^(b) Interference may occur in the vicinity of equipment marked with the following symbol:



NOTE 1: At 80 MHz and 800 MHz, the higher frequency range applies.

NOTE2: These guidelines may not apply in all situations. Electromagnetic propagation is affected by absorption and reflection from structures, objects, and people.

^(a) Field strengths from fixed

tions for radio (cellular/cordless) telephones and land mobile radios, dcast cannot be predicted theoretically with accuracy. To assess itters, an electromagnetic site survey should be considered. If Automated Impella Controller is used exceeds the applicable RF ler should be observed to verify normal operation. If abnormal necessary, such as re-orienting or relocating the Automated Impella

ngths should be less than 10 V/m

Table 8.8 Guidance and manufacturer's declaration - emissions, equipment and systems that are life-supporting

Immunity Test	Compliance Level
Avionics RTCA DO-160G	
Conducted RF Section 20.4	Category R 10 MHz - 400MHz
Radiated RF Section 20.5	Category T (c) 100 MHz - 8 GHz
(c) the AIC will not maintain its essential performance when subjected to Category R Levels (radiated RF at a field strength of 150 V/m).	

Immunity Test		
RFID AIM 7351731:2017		
RFID Specification	Frequency	Text Level (RMS)
ISO 14223	134.2kHz	65 A/m
ISO/IEC 14443-3 (Type A)	13.56 MHz	7.5 A/m
ISO/IEC 14443-4 (Type B)	13.56 MHz	7.5 A/m
ISO/IEC 15693 (ISO 18000-3 Mode 1)	13.56 MHz	12 A/m
ISO/IEC 18000-7	433 MHz	3 V/m
ISO/IEC 18000-63 Type Ca	890-960 MHz	54 V/m
ISO/IEC 18000-4 Mode 1	2.45 GHz	54 V/m

Table 8.9 Recommended separation distances between portable and mobile RF communications equipment and the Automated Impella Controller, equipment and systems that are life-supporting

The Automated Impella Controller is intended for use in the electromagnetic environment in which radiated disturbances are controlled. The customer or user of the Automated Impella Controller can help prevent electromagnetic interference by maintaining a minimum distance between portable and mobile RF communications equipment and the Automated Impella Controller as recommended below, according to the maximum output power of the communications equipment.

Rated Maximum Output Output Power of Transmitter (Watts)	Recommended Separation Distances for the Automated Impella Controller (m)		
0.01	0.04	0.06	0.12
0.1	0.11	0.19	0.38
1	0.35	0.6	1.2
10	1.11	1.9	3.8
100	3.5	6.0	12

For transmitters rated at a maximum output power not listed above, the recommended separation distance (d) in meters (m) can be determined using the equation applicable to the frequency of the transmitter, where P is the maximum output power rating of the transmitter in watts (W) according to the transmitter manufacturer.

NOTE 1: At 80 MHz and 800 MHz, the separation distance for the higher frequency range applies.

NOTE 2: These guidelines may not apply in all situations. Electromagnetic propagation is affected by absorption and reflection from structures, objects, and people.

Table 8.10 RFID transmitter / receiver specifications

RFID Transmitter / Receiver Specifications	
Frequency	13.56 MHz
Receiver bandwidth	14 kHz
Effective radiated power	30 nW
Modulation	ASK

Table 8.11 Impella Connect® Wi-Fi transmitter / receiver specifications

IEEE Protocols	802.11a, 802.11b, 802.11g, and 802.11n			
Receiver bandwidth	120 MHz/ 40 MHz			
Effective radiated power	<0.071 watts			
Frequency Bands	2412 MHz to 2462 MHz US 2412 MHz to 2472 MHz EU 2412MHz to 2684MHzJP 5180 MHz to 5825 MHz US 5180 MHz to 5700 MHz EU 5180 MHz to 5700 MHz JP			

IEEE	802.11a	802.11b	802.11g	802.11n
Modulation	OFDM	D5.55	OFDM	MxMO OFMD

Video Frame Rate	20 fps (Maximum)
Data Rate	512 Kbps (Average)

Certified Wi-Fi Module	
Manufacturer:	Texas Instruments
Part number:	WL18MODGI
FCC ID: Z64-WL18DBMOD	

TRANSPORT BETWEEN HOSPITALS



The Automated Impella Controller (AIC) performs as intended when exposed to radiofrequency (RF) disturbances below 20 V/m. During transport, the AIC may be exposed to RF disturbances above 20 V/m, which could cause minor problems, such as intermittent displays of soft button menu selections, which have no effect on the operating parameters of the Impella support system, and will resolve readily once the disturbance ends. It could also potentially result in loss of support. Patients must be closely monitored at all times during transport.



Do not transport an Impella patient via commercial aircraft. Loss of support may occur aboard a commercial aircraft due to exposure to radiofrequency (RF) disturbances above the compliance level (<20 V/m) of the Automated Impella Controller.

GUIDELINES FOR PATIENT TRANSPORT

Intra-hospital transport may be required if a patient requires additional resources and specialized teams located at another hospital. The patient may be transferred to such a location using the Automated Impella Controller for hospital-to-hospital transport via ambulance, or helicopter, or fixed-wing aircraft specially outfitted and equipped for transport of critically ill patients. Do not transport the patient via commercial aircraft. Loss of support may occur aboard a commercial aircraft due to exposure to extreme radiofrequency (RF) disturbances.

Patients must be closely monitored at all times during transport. Maintaining optimal patient hemodynamic status and correct Impella Catheter position are two key factors in managing patients supported with the Impella Ventricular Support Systems during transport. Steps should be taken to eliminate or minimize any aspect of the transport that might adversely affect these factors.

The Automated Impella Controller is designed to operate for 60 minutes on battery power. Transport teams should take this into consideration when planning the transport. If the total transport time is expected to include more than 60 minutes during which the system will be disconnected from AC power, arrangements should be made to use a vehicle with a built-in DC to AC power inverter.

IMPORTANT TRANSPORT CONSIDERATIONS

1. Planning is critical to success. Abimed representatives can help with planning for transport. They can be contacted 24 hours a day at 1-800-422-8666.
2. The Automated Impella Controller should be fully charged prior to transport. Keep the Automated Impella Controller connected to AC power (or an AC inverter) whenever possible.
3. Do not stress the connector cable from the controller to the Impella Catheter. Such tension could move the catheter out of correct position and compromise patient circulatory support.
4. Carefully monitor purge pressures during changes in altitude.
5. The Automated Impella Controller should be positioned to allow easy access to the displayscreen and soft buttons to view alarms and make any necessary changes.
6. Maintain ACTs between 160 and 180 or at the level recommended by the physician responsible for the patient.

FAA ADVISORY

The Automated Impella Controller has been subjected to, and passed, the EMC/EMI tests as specified in IEC 60601-1-2 (General requirements for safety—Collateral standard: Electromagnetic compatibility—Requirements and tests). The Automated Impella Controller does not, however, meet the requirements for conducted emissions of RTCA/DO-160G section 21.4 and has not been tested for radiated emissions per RTCA/DO-160G section 21.5. Abiomed recommends that air transport carriers follow the guidance FAA Advisory Circular AC No: 91-21.1B. Section 8-a of FAA Advisory Circular AC No: 91-21.1B states:

“Equipment tested and found to exceed the section 21, Category M, emission levels are required to be evaluated in the operator’s M-PED selected model aircraft for electromagnetic interference (EMI) and radio frequency interference (RFI). All navigation, communication, engine, and flight control systems will be operating in the selected aircraft during the evaluation.”

TRANSPORT WITHIN THE HOSPITAL

Patients supported with the Impella System may require transport within the hospital.

Considerations for transport within the hospital:

- The Automated Impella Controller and Impella Catheter are designed to operate on battery power for at least 1 hour.
- Confirm that the battery capacity displayed on the controller is 100%.
- If transport time might be longer than 1 hour, bring an extension cord or confirm that you will be able to connect the controller to AC power once you arrive at your destination.
- When rolling the Automated Impella Controller cart across a threshold, firmly grasp the cart handle and pull it over the threshold.
- Pay close attention to all system components and connections when rolling the Automated Impella Controller cart over thresholds and through elevator doors.
- Do not stress the connector cable from the controller to the Impella Catheter.

VGA MONITOR CONNECTION

The Automated Impella Controller, which is equipped with a VGA output connector, which can be connected to a remote monitor to display the information from the controller to another screen at a resolution of 800 x 600 pixels. The connection between the controller and the monitor can be made using a cable up to 20 feet in length. If the AIC has the optional Impella Connect MDDS attached, the VGA Output connector is located on the back of the Impella Connect. The Impella Connect, can be used to transfer the video stream from the AIC, to a remote viewing location (via the internet).

The communication between the Impella Connect and the AIC is one-way. The streamed video data is limited to Impella device operating parameters and alarms messages. There is no patient identifiable information on any of the AIC screens. The Impella Connect will have to be configured by the hospital's IT department to access approved wireless networks. The video stream displayed via the Impella Connect web app enables remote patient monitoring by providing authorized users with passive viewing of the AIC's display which includes information on alarms and hemodynamic data useful for troubleshooting and managing Impella devices to aid in patient management.



During use with the Impella Connect, a Medical Device Data System (MDDS), if the Automated Impella Controller is exposed to strong electromagnetic disturbances, the Impella Connect may either restart or shut down. Operators should be aware that, under these conditions, the Automated Impella Controller operating parameters are not affected.



Do not insert any unauthorized devices into the USB port. This includes chargers, memory sticks, wireless dongles and other unauthorized devices.

ALARM DELAY INFORMATION

For some Automated Impella Controller alarms, there is a short delay between the triggered event and the audible annunciation and visual display of the alarm.

Table 8.12 Alarm Delay Information

Impella Defective	8 second delay
Controller Error	12±3 second delay
Emergency Shutdown Imminent	15±1 second delay
Battery Failure	28±8 second delay
Controller Failure	38±8 second delay
Battery Comm. Failure	40±10 second delay
Purge System Blocked	75±45 second delay

PATIENT ENVIRONMENT

The Automated Impella Controller and the components of the Impella RP System are approved for use within the patient environment defined in IEC 60601-1:3rd edition and in the figure below.

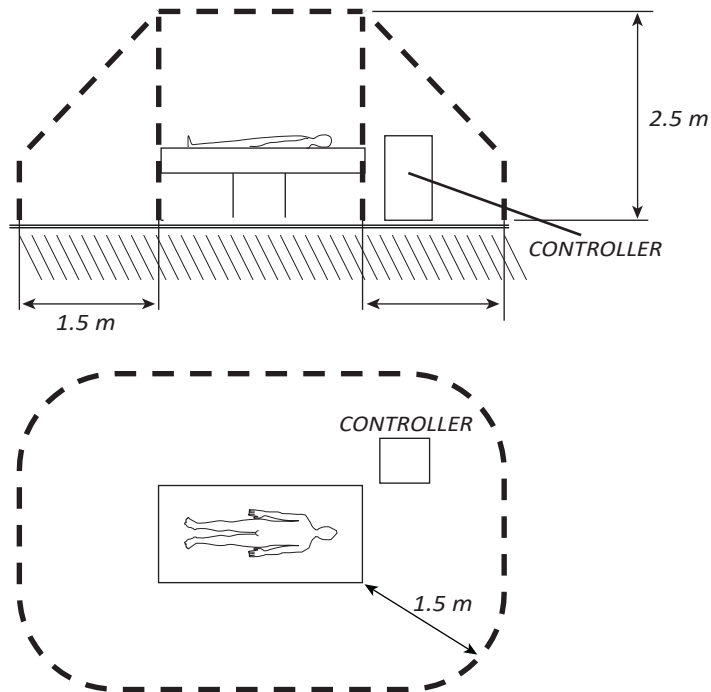

Figure 8.1 Automated Impella Controller Patient Environment

USE ENVIRONMENT

The Automated Impella Controller system is suitable for use in hospital and transport environments. For additional detail, please refer to section 2.1 and section 8 .

WHITE CONNECTOR CABLE

Length	2.5 m
Service life	Single use only

IMPELLA RP SYSTEM CATHETER PARAMETERS

Table 8.13 Impella Catheter Parameters

Speed range	0 to 33,000 rpm
Power consumption	Less than 23 W
Voltage	Max. 20 V DC
Flow-Maximum	4.0 L/min
Purging the Impella RP System Catheter	
Recommended purge fluid	5% dextrose solution in water with heparin concentration of 25 or 50 IU per mL
Dextrose concentration	5% to 20%
Purge pressure	300 to 1100 mmHg
Purge flow	2 to 30 mL/hr
Maximum duration of use	
US	Up to 14 days
Dimensions of Impella RP System Catheter	
Length of invasive portion (without catheter)	Approx 238 mm
Diameter	Max. 7.6 mm
Classification per DIN EN 60601-1	Protection class I, degree of protection: CF (Automated Impella Controller and Impella RP System Catheter)
Classification per directive 93/42/EEC	Class III
Latex content	Not made with natural rubber latex

Latex

The Automated Impella Controller and Impella RP System Catheter, including all accessories, are not made with natural rubber latex.

Alcohol Warning

Do NOT clean the Impella Catheter infusion filter or pressure reservoir with alcohol and AVOID exposing these components to products containing alcohol.

Storing the Controller

To keep the Automated Impella Controller battery charged, the controller should be plugged into an AC outlet. When plugged into an AC outlet, the controller battery will charge whether the controller is on or off.

CLEANING

- Clean the Automated Impella Controller keypad and display with either 70% isopropyl alcohol or soap and water. (NOTE: Be aware that soft buttons may be activated when you spray or wipe the display.)
- Clean the Automated Impella Controller housing with mild detergent.
- Do not allow any fluids to enter the connector sockets.
- Clean the connector cable with 70% isopropyl alcohol.

STORING THE AUTOMATED IMPELLA CONTROLLER



The Li-Ion batteries must be charged for 5 hours prior to system operation in order to meet the runtime requirement of 1 hour. Failure to do so will yield a shorter runtime. After being unplugged, the Automated Impella Controller will operate for at least 60 minutes after the batteries have been fully charged.

- Place the Automated Impella Controller on a horizontal surface to prevent falling.
- Connect the AC power cord to an AC outlet.
- The battery may be destroyed if the Automated Impella Controller is stored with a depleted battery.

RETURNING AN IMPELLA RP SYSTEM CATHETER TO ABIOMED (UNITED STATES)

To return an Impella RP System Catheter to Abiomed, contact your local Clinical Consultant for an Abiomed-approved return kit.* The kit includes instructions for returning the Impella RP System Catheter to Abiomed.

** Only available in the United States*



APPENDIX A: AUTOMATED IMPELLA CONTROLLER MENU STRUCTURE ... A.1

- OverviewA.1
- Mute AlarmA.1
- Flow Control.....A.1
- Display..... A.2
- Purge Menu.....A.2
- MenuA.3

APPENDIX A: AUTOMATED IMPELLA CONTROLLER MENU STRUCTURE

OVERVIEW

The soft buttons on the Automated Impella Controller provide access to the controller menu structure. The menu structure has 5 main elements:

- **MUTE ALARM**
- **FLOW CONTROL**
- **DISPLAY**
- **PURGE MENU**
- **MENU**

This Appendix provides an overview of the Automated Impella Controller menu structure. Many of the functions accessed through this menu structure are also discussed elsewhere in this manual.

MUTE ALARM

The **MUTE ALARM** soft button mutes (silences) active alarms. It does not open another menu.

When you press **MUTE ALARM**, a bell icon with an X through it replaces the words "MUTEALARM" in the upper right of the displayscreen. If no alarms are active, no bell icon is displayed. When you press **MUTE ALARM** it acknowledges all active alarms and silences the audible alarm indicator for 2 minutes (for red or yellow alarms) or 5 minutes (for white alarms). (Refer to section 7 of this manual for more information about Automated Impella Controller Alarms.)

FLOW CONTROL

The **FLOW CONTROL** soft button opens the performance level icon enabling you to select the desired performance level. The procedure for setting performance level is described in "Positioning and Starting the Impella RP System Catheter" in section 5.

DISPLAY

The **DISPLAY** soft button opens a menu that includes the following options for viewing waveforms and navigating to other screen displays:

- **Y-axis Scale**—opens a menu from which you can select a waveform and change its appearance by adjusting the scale of the y-axis.
 - Once the waveform is selected, turn the selector knob clockwise to increase the y-axis scale and counterclockwise to decrease the y-axis scale.
 - Select **OK** to accept the new y-axis scale.
 - Select **Restore** to return to the default y-axis scale.
 - Select **Initial** to set the y-axis to the previously set scale.
 - Select **Center Signal** to center the waveform.
 - Select **Cancel** to exit the tool.
- **Time Scale**—allows you to apply different time scales to the currently displayed waveforms.
- **Center**—automatically centers the motor current waveform and adjusts the range accordingly.
- **Infusion**—opens the infusion history screen. The infusion history screen, which is discussed in section 4 of this manual, shows the volume and the amount of heparin and dextrose delivered. The top entry in the table shows the volume and amount of heparin and dextrose infused from the top of the hour through the current time.
- **Purge**—displays the purge system waveforms and pressure and flow values.
- **Placement**—opens the placement signal/motor current screen (described in section 4 under “Placement Screen”).
- **Display Speed Pulse**— allows you to see the speed pulses in the motor current.

PURGE MENU

The **PURGE MENU** soft button opens a menu that includes the following purge system procedure options:

- **Change Purge Fluid Bag**—starts the procedure to change the purge fluid
- **Change Cassette and Bag**—starts the procedure to change both the purge fluid and purge cassette
- **De-Air Purge System**—starts the de-air procedure

These procedures are described in section 5 of this manual.

MENU

The **MENU** soft button opens a menu of options related to controller settings, alarm history, repositioning, offset adjustment, and starting a procedure. The menu includes the following options:

- **Settings / Service**

Service

System Information. Opens the System Information table. This provides information about the software version, IP addresses, current type of Impella Catheter, and current catheter runtime.

Set Date/Time. Displays the menu for changing the date and time

USB Data Download. When no pump is connected, this display appears for downloading data logs to a USB device

Service Timers. Displays the Service Timers menu. Console operating time and purge motor operating time are displayed in hours.

Screen Brightness. Opens the Screen Brightness selection box. The brightness of the screen display can be set from 50% to 100%. Select **OK** to confirm selection. Select **Cancel** to cancel selection.

Language. When the software supports multi-language, this opens the Language selection box. Opens the Language selection box. Use the selector knob to select German, English, French, Italian, Spanish, or Dutch. The system will immediately change the language on the controller for all displayed text. This language will be used after system restart unless another language is selected.

Disable (Enable) Retrograde Flow Control.

Disable (Enable) Audio—Placement Signal not Reliable. Allows you to enable or disable audio for the Impella Placement Signal not Reliable alarm. This selection is available only if an Impella Placement Signal not Reliable alarm is active or the audio has been disabled for this alarm.

Disable (Enable) Audio—Purge Pressure High / System Blocked. Allows you to enable or disable audio for the Purge Pressure High or Purge System Blocked alarms. This selection is only available if one of these two alarms is active or the audio has been disabled for one of these alarms.

Disable (Enable) Audio - Suction. Allows you to enable or disable audio for Suction alarms. This selection is available only if a Suction alarm is active or the audio has been disabled for this alarm.

Enable (Disable) Purge Flow Change Notifications. Allows you to enable or disable the purge flow notification white alarms ("Purge Flow Increased" and "Purge Flow Decreased").

Enable (Disable) Surgical Mode. Allows you to enable or disable Surgical Mode. If Surgical Mode is enabled, the "Impella Stopped" alarm is silenced at P-0.

- **Alarm History**—opens the Alarm History table. This provides a visual display of the chronology of stored alarm messages. The most recently occurring alarm message is displayed at the top of the list. For each message, the date and time it occurred and the alarm message heading is displayed. You can use the selector knob to select individual alarm messages and an explanation for the selected alarm message will be displayed in the failure description box. Press **EXIT** to exit the alarm history analysis.
- **Start Data Snapshot**—starts the timed data recording function to save real-time operating data for later analysis.
- **Start Manual Zero**—opens the procedure for manually zeroing the differential pressure sensor.
- **Case Start**—begins the case procedure. Case Start is described in section 5 of this manual under “Case Start.”



Clinical support 24 hours per day, 7 days a week:

1-800-422-8666 (US)

+49 (0) 1805 2246633 (EU)

www.abiomed.com

Abiomed, Inc.
22 Cherry Hill Drive
Danvers, Massachusetts 01923 USA
Voice: 978-777-5410
Facsimile: 978-777-8411
Email: clinical@abiomed.com

Abiomed Europe GmbH
Neuenhofer Weg 3
52074 Aachen, Germany
Voice: +49 (0) 241 8860-0
Facsimile: +49 (0) 241 8860-111
Email: europe@abiomed.com